



Count on it.

Operator's Manual

STX-38 EFI Stump Grinder with Intelli-Sweep

Model No. 23214—Serial No. 31500001 and Up

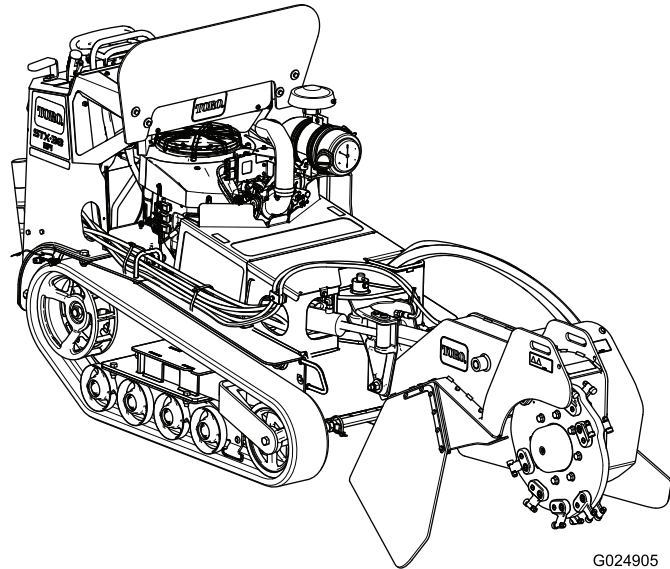

G024905



▲ WARNING

CALIFORNIA Proposition 65 Warning

This product contains a chemical or chemicals known to the State of California to cause cancer, birth defects, or reproductive harm.

The engine exhaust from this product contains chemicals known to the State of California to cause cancer, birth defects, or other reproductive harm.

▲ DANGER

There may be buried utility lines in the work area. If you dig into them, you may cause a shock or explosion.

Have the property or work area marked for buried lines and do not dig in marked areas. Contact your local marking service or utility company to have the property marked (for example, in the United States, call 811 for the nationwide marking service).

This spark ignition system complies with Canadian ICES-002.

Because in some areas there are local, state, or federal regulations requiring that a spark arrester be used on the engine of this machine, a spark arrester is available as an option. If you require a spark arrester, contact your Authorized Toro Service Dealer.

Genuine Toro spark arresters are approved by the USDA Forestry Service.

Important: It is a violation of California Public Resource Code Section 4442 to use or operate the engine on any forest-covered, brush-covered, or grass-covered land without a spark arrester muffler maintained in working order, or the engine constricted, equipped, and maintained for the prevention of fire. Other states or federal areas may have similar laws.

The enclosed *Engine Owner's Manual* is supplied for information regarding the US Environmental Protection Agency (EPA) and the California Emission Control Regulation of emission systems, maintenance, and warranty. Replacements may be ordered through the engine manufacturer.

This product complies with all relevant European directives. For details, please see the separate product specific Declaration of Conformity (DOC) sheet.

Introduction

This machine is designed to grind and remove tree stumps and surface roots. It is not intended to cut rock or any other material other than wood and the soil around a stump.

Read this information carefully to learn how to operate and maintain your product properly and to avoid injury and product damage. You are responsible for operating the product properly and safely.

You may contact Toro directly at www.Toro.com for product and accessory information, help finding a dealer, or to register your product.

Whenever you need service, genuine Toro parts, or additional information, contact an Authorized Service Dealer or Toro Customer Service and have the model and serial numbers of your product ready. [Figure 1](#) illustrates the location of the model and serial numbers on the product. Write the numbers in the space provided.

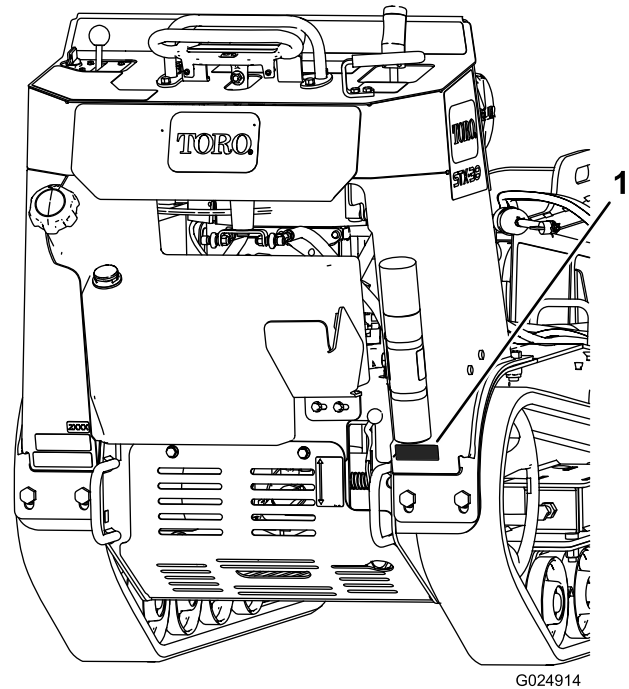

Figure 1

1. Model and serial number plate

Model No. _____

Serial No. _____

This manual identifies potential hazards and has safety messages identified by the safety alert symbol ([Figure 2](#)), which signals a hazard that may cause serious injury or death if you do not follow the recommended precautions.



Figure 2

1. Safety alert symbol

This manual uses 2 words to highlight information.

Important calls attention to special mechanical information and **Note** emphasizes general information worthy of special attention.

Contents

Safety	4
Safe Operating Practices	4
Sound Pressure	6
Sound Power	6
Hand-Arm Vibration Level	6
Slope Indicator	7
Safety and Instructional Decals	8
Setup	11
Checking Fluid Levels	11
Charging the Battery	11
Opening the Lift Valve	11
Product Overview	11
Controls	11
Specifications	14
Attachments/Accessories	14
Operation	15
Adding Fuel	15
Checking the Engine-oil Level	16
Starting and Stopping the Engine	16
Stopping the Machine	17
Moving a Non-functioning Machine	17
Grinding a Stump	17
Securing the Machine for Transport	18
Lifting the Machine	18
Operating Tips	19
Maintenance	20
Recommended Maintenance Schedule(s)	20
Premaintenance Procedures	20
Removing the Front Cover	20
Installing the Front Cover	21
Removing the Bottom Shield	21
Installing the Bottom Shield	21
Lubrication	22
Greasing the Machine	22
Engine Maintenance	23
Servicing the Air Cleaner	23
Servicing the Engine Oil	23
Servicing the Spark Plugs	26
Fuel System Maintenance	27
Draining the Fuel Tank	27
Replacing the Low-pressure Fuel Filter	27
Servicing the High-pressure Fuel Filter	28
Electrical System Maintenance	28

Servicing the Battery	28
Replacing the Fuses	30
Drive System Maintenance	31
Servicing the Tracks	31
Cooling System Maintenance	33
Cleaning the Engine Screen	33
Belt Maintenance	34
Replacing the Pump Drive Belt	34
Controls System Maintenance	34
Adjusting the Traction Control Alignment	34
Adjusting the Traction Control Neutral Position	35
Adjusting the Tracking of the Traction Control, Full Forward Position	35
Hydraulic System Maintenance	36
Checking the Hydraulic-fluid Level	36
Replacing the Hydraulic Filter	37
Changing the Hydraulic Fluid	38
Checking the Hydraulic Lines	38
Grinder Maintenance	39
Replacing the Teeth	39
Cleaning	39
Removing Debris from the Machine	39
Storage	40
Troubleshooting	41
Schematics	42

Safety

Improper use or maintenance can result in injury. To reduce the potential for injury, comply with these safety instructions and always pay attention to the safety alert symbol **A**, which means: **Caution, Warning, or Danger**—personal safety instruction. Failure to comply with the instruction may result in personal injury or death.

Safe Operating Practices

This product is capable of amputating hands and feet. Always follow all safety instructions to avoid serious injury or death.

A WARNING

Engine exhaust contains carbon monoxide, an odorless, deadly poison that can kill you.

Do not run the engine indoors or in an enclosed area.

Training

- Read the *Operator's Manual* and other training material. If the operator(s) or mechanic(s) cannot read or understand the information, it is the owner's responsibility to explain this material to them.
- Become familiar with the safe operation of the equipment, operator controls, and safety signs.
- All operators and mechanics should be trained. The owner is responsible for training the users.
- Never let children or untrained people operate or service the equipment. Local regulations may restrict the age of the operator.
- The owner/user can prevent and is responsible for accidents or injuries occurring to people or damage to property.

Preparation

- Evaluate the terrain to determine what accessories and attachments are needed to properly and safely perform the job. Only use accessories and attachments approved by the manufacturer.
- Wear appropriate clothing including hard hat, **a full face shield**, safety glasses, long pants, substantial safety shoes, and hearing protection. Long hair, loose clothing or jewelry may get tangled in moving parts.
- Inspect the area where the equipment is to be used and remove all objects such as rocks, toys, and wire which can be thrown by the machine.
- Check that the operator presence controls, safety switches, and shields are attached and functioning properly. Do not operate unless they are functioning properly.

Operation

- Never run an engine in an enclosed area.
- Only operate in good light, keeping away from holes and hidden hazards.
- Be sure all drives are in neutral before starting the engine. Only start the engine from the operator's position.
- Slow down and use extra care on hillsides. Be sure to travel in the recommended direction on hillsides. Turf conditions can affect the machine's stability.
- Never operate with the guards not securely in place. Be sure all interlocks are attached, adjusted properly, and functioning properly.
- Do not change the engine governor setting or overspeed the engine.
- Stop on level ground, lower the grinder, disengage the hydraulics, and shut off the engine before leaving the operator's position for any reason.
- Keep hands and feet away from the moving grinder wheel and teeth.
- Look behind and down before backing up to be sure of a clear path.
- Keep pets and bystanders away.
- Do not operate the machine under the influence of alcohol or drugs.
- Use care when loading or unloading the machine into or out of a trailer or truck.
- Ensure that the area is clear of other people before operating the machine. Stop the machine if anyone enters the area.
- Never leave a running machine unattended. Always lower the grinder, stop the engine, and remove the key before leaving.
- Never jerk the controls; use a steady motion.
- Watch for traffic when operating near roadways.
- Do not touch parts which may be hot from operation. Allow them to cool before attempting to maintain, adjust, or service.
- Ensure that you operate the machine in areas where there are no obstacles in close proximity to the operator. Failure to maintain adequate distance from trees, walls, and other barriers may result in injury as the machine backs up during operation if the operator is not attentive to the surroundings. Only operate the unit in areas where there is sufficient clearance for the operator to safely maneuver the product.
- Before grinding, have the area marked for underground utilities, and do not grind into the ground in marked areas.
- Locate the pinch point areas marked on the machine and keep hands and feet away from these areas.
- Lightning can cause severe injury or death. If lightning is seen or thunder is heard in the area, do not operate the machine; seek shelter.

Safe Handling of Fuels

- To avoid personal injury or property damage, use extreme care in handling gasoline. Gasoline is extremely flammable and the vapors are explosive.
- Extinguish all cigarettes, cigars, pipes, and other sources of ignition.
- Use only an approved fuel container.
- Never remove fuel cap or add fuel with the engine running.
- Allow engine to cool before refueling.
- Never refuel the machine indoors.
- Never store the machine or fuel container where there is an open flame, spark, or pilot light such as on a water heater or on other appliances.
- Never fill containers inside a vehicle or on a truck or trailer bed with a plastic liner. Always place containers on the ground away from your vehicle before filling.
- Remove equipment from the truck or trailer and refuel it on the ground. If this is not possible, then refuel such equipment with a portable container, rather than from a fuel dispenser nozzle.
- Keep the nozzle in contact with the rim of the fuel tank or container opening at all times until fueling is complete.
- Do not use a nozzle lock open device.
- If fuel is spilled on clothing, change clothing immediately.
- Never overfill fuel tank. Replace fuel cap and tighten securely.

Slope Operation

Slopes are a major factor related to loss-of-control and tip-over accidents, which can result in severe injury or death. All slopes require extra caution.

- Do not operate the machine on hillsides or slopes exceeding the angles recommended in the following table.

Front Facing Uphill	Rear Facing Uphill	Side Facing Uphill
16°	16°	16°

Note: See also the [Slope Indicator \(page 7\)](#).

- **Operate up and down slopes with the front end of the machine uphill.**
- Remove obstacles such as rocks, tree limbs, etc. from the work area. Watch for holes, ruts, or bumps, as uneven terrain could overturn the machine. Tall grass can hide obstacles.
- Use only Toro-approved accessories. Accessories can change the stability and the operating characteristics of the machine. Warranty may be voided if used with unapproved accessories.
- Keep all movements on slopes slow and gradual. Do not make sudden changes in speed or direction.

- Avoid starting or stopping on a slope. If the machine loses traction, proceed slowly, straight down the slope.
- Avoid turning on slopes. If you must turn, turn slowly and keep the heavy end of the machine uphill.
- Do not operate near drop-offs, ditches, or embankments. The machine could suddenly turn over if a track goes over the edge of a cliff or ditch, or if an edge caves in.
- Do not operate on wet grass. Reduced traction could cause sliding.
- Do not park the machine on a hillside or slope without lowering the grinder to the ground and chocking the tracks.

Maintenance and Storage

- Disengage the hydraulics, lower the grinder, stop the engine, and remove the key. Wait for all movement to stop before adjusting, cleaning, or repairing.
- Clean debris from the grinder, drives, mufflers, and engine to help prevent fires. Clean up oil or fuel spillage.
- Let the engine cool before storing and do not store near flame.
- Do not store fuel near flames or drain indoors.
- Park the machine on level ground. Never allow untrained personnel to service the machine.
- Use jack stands to support components when required.
- Carefully release pressure from components with stored energy.
- Disconnect the battery or remove the spark plug wires before making any repairs. Disconnect the negative terminal first and the positive last. Reconnect positive first and negative last.
- Keep hands and feet away from moving parts. If possible, do not make adjustments with the engine running.
- Keep all parts in good working condition and all hardware tightened. Replace all worn or damaged decals.
- Keep nuts and bolts tight. Keep equipment in good condition.
- Never tamper with safety devices.
- Keep the machine free of grass, leaves, or other debris build-up. Clean up oil or fuel spillage. Allow the machine to cool before storing.
- Stop and inspect the equipment if you strike a foreign object outside of the stump wood. Make any necessary repairs before restarting.
- Use only genuine Toro replacement parts to ensure that original standards are maintained.
- Battery safety:
 - Charge batteries in an open, well ventilated area, away from spark and flames. Unplug the charger before connecting or disconnecting it from the battery. Wear protective clothing and use insulated tools.

- Battery acid is poisonous and can cause burns. Avoid contact with skin, eyes, and clothing. Protect your face, eyes, and clothing when working with a battery.
- Battery gases can explode. Keep cigarettes, sparks and flames away from the battery.
- Keep your body and hands away from pin hole leaks or nozzles that eject high pressure hydraulic fluid. Use cardboard or paper to find hydraulic leaks; never use your hands. Hydraulic fluid escaping under pressure can penetrate skin and cause injury requiring surgery within a few hours by a qualified surgeon or gangrene may result.

Hauling

- Use care when loading or unloading the machine into a trailer or truck.
- Use full width ramps for loading machine into trailer or truck.
- Tie the machine down securely using straps, chains, cable, or ropes. Both front and rear straps should be directed down and outward from the machine.

Sound Pressure

This unit has a sound pressure level at the operator's ear of 92 dBA, which includes an Uncertainty Value (K) of 1 dBA.

Sound pressure level was determined according to the procedures outlined in EN ISO 11201.

The sound pressure level will vary depending on conditions.

Sound Power

This unit has a sound power level of 109 dBA, which includes an Uncertainty Value (K) of 3.75 dBA.

The sound power level was determined with no load according to the procedures outlined in ISO 3744.

Hand-Arm Vibration Level

Declared in accordance with EN 12096

Measured vibration level for right hand = 2.2 m/s²

Measured vibration level for left hand = 2.3 m/s²

Uncertainty Value (K) = 1.2 m/s²

Measured values were determined according to the procedures outlined in EN ISO 20643.

Slope Indicator

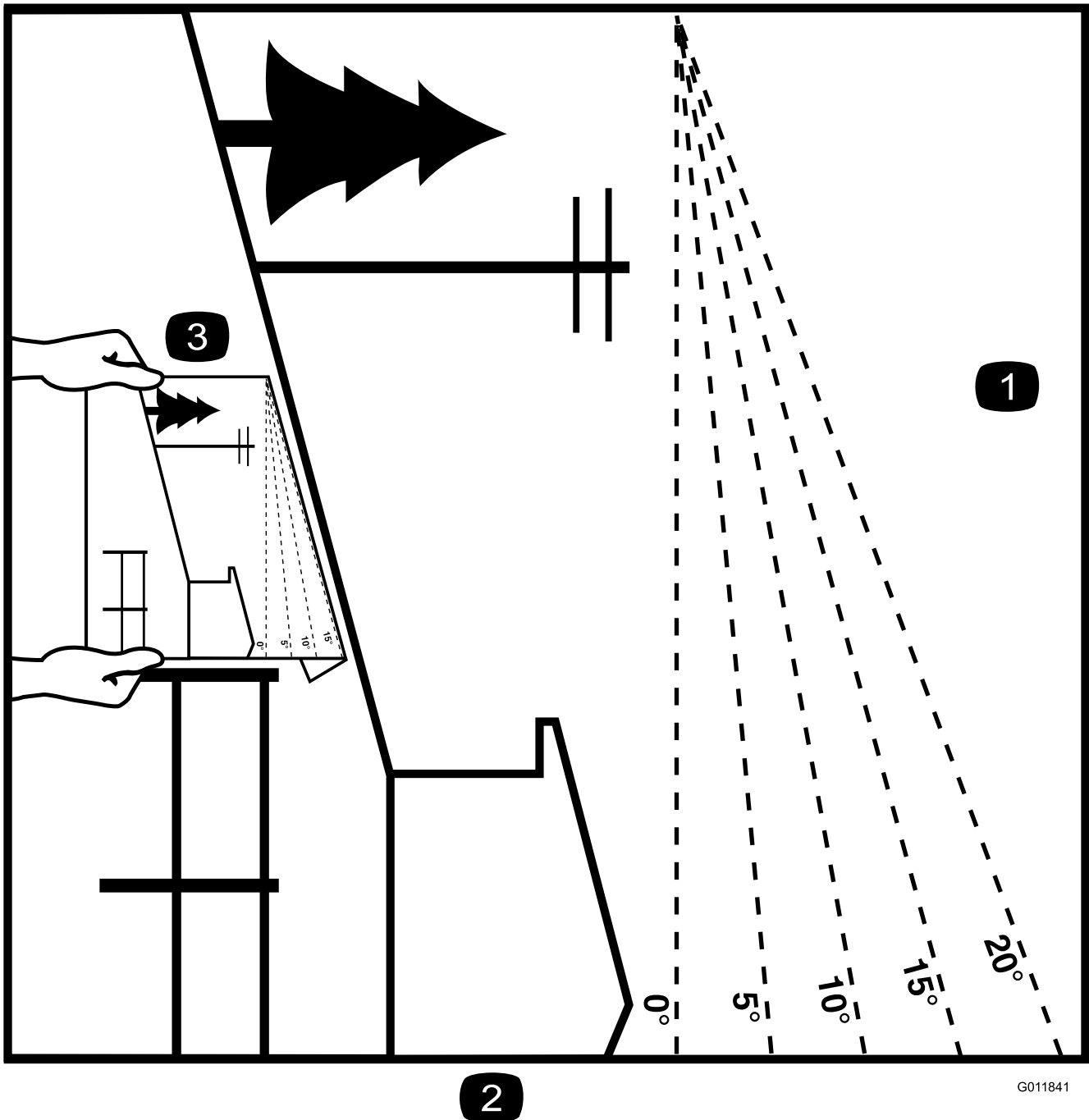

2

G011841

Figure 3

This page may be copied for personal use.

1. The maximum slope you can safely operate the machine on is 16 degrees. Use the slope chart to determine the degree of slope of hills before operating. Do not operate this machine on a slope greater than 16 degrees. Fold along the appropriate line to match the recommended slope.
2. Align this edge with a vertical surface, a tree, building, fence pole, etc.
3. Example of how to compare slope with folded edge.

Safety and Instructional Decals



Safety decals and instructions are easily visible to the operator and are located near any area of potential danger. Replace any decal that is damaged or lost.

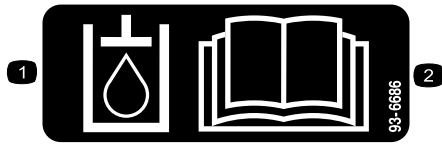

93-6686

1. Hydraulic oil
2. Read the Operator's Manual.

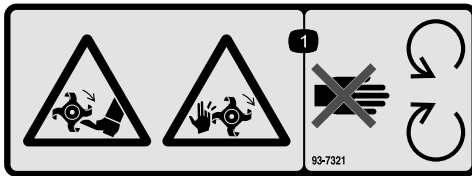

93-7321

1. Cutting/dismemberment hazard of hands and feet, rotating knives/blades—stay away from moving parts.

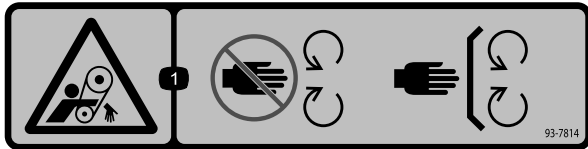

93-7814

1. Entanglement hazard, belt—stay away from moving parts.

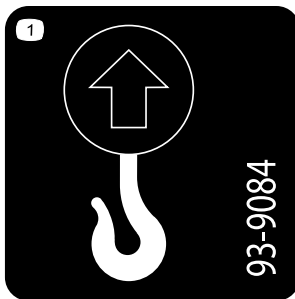

93-9084

1. Lift point
2. Tie-down point



93-9363

1. Parking brake
2. Locked
3. Unlocked

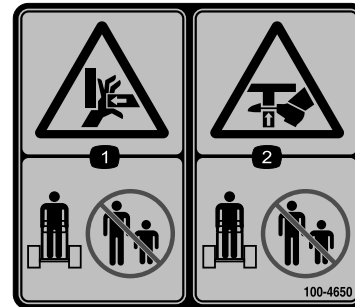

100-4650

1. Crushing hazard of hand—keep bystanders a safe distance from the machine.
2. Crushing hazard of foot—keep bystanders a safe distance from the machine.



107-9366

1. Thrown object hazard—keep bystanders a safe distance from the machine.



115-2047

1. Warning—do not touch the hot surface.

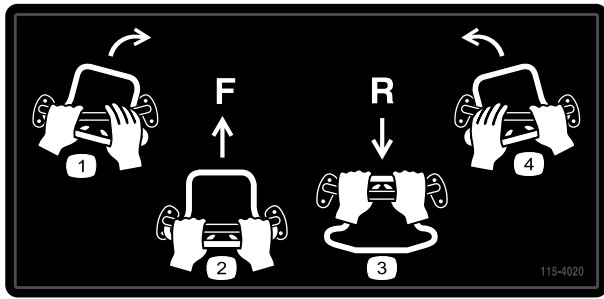

115-4020

1. Turn right
2. Forward
3. Reverse
4. Turn left

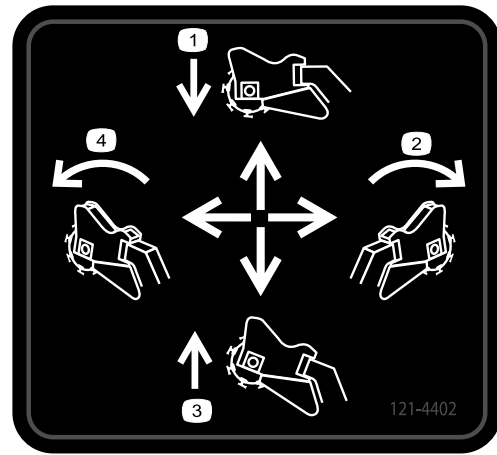

121-4402

1. Push forward to lower the stump grinder
2. Move right to move the stump grinder to the right
3. Pull back to raise the stump grinder
4. Move left to move the stump grinder to the left

CALIFORNIA SPARK ARRESTER WARNING

Operation of this equipment may create sparks that can start fires around dry vegetation. A spark arrester may be required. The operator should contact local fire agencies for laws or regulations relating to fire prevention requirements. 117-2718

117-2718



Battery Symbols

Some or all of these symbols are on your battery

1. Explosion hazard
2. No fire, open flame, or smoking.
3. Caustic liquid/chemical burn hazard
4. Wear eye protection
5. Read the *Operator's Manual*.
6. Keep bystanders a safe distance from the battery.
7. Wear eye protection; explosive gases can cause blindness and other injuries
8. Battery acid can cause blindness or severe burns.
9. Flush eyes immediately with water and get medical help fast.
10. Contains lead; do not discard.

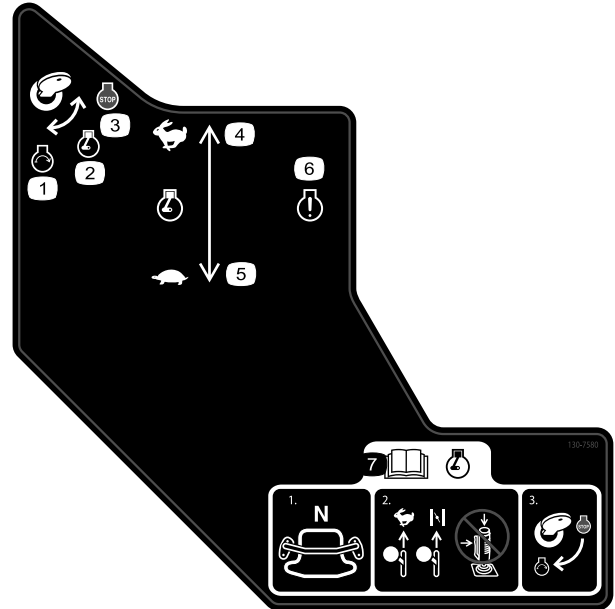

130-7580

1. Engine—start
2. Engine—run
3. Engine—stop
4. Engine speed—fast
5. Engine speed—slow
6. Engine indicator light
7. Read the *Operator's Manual* before starting the engine—1) Ensure that the traction control is in the neutral position; 2) Move the throttle lever to the Fast position, close the choke (if applicable), and do not operate the joystick; 3) Turn the key to start the engine.



119-4606

1. Warning—read the *Operator's Manual*.
2. Cutting/dismemberment hazard; grinder—keep bystanders a safe distance from the machine; do not operate the grinder head while transporting the machine.
3. Warning—stay away from moving parts; wait for all moving parts to stop.
4. Warning—do not operate this machine unless you are trained.
5. Explosion and electric shock hazard—do not dig in areas with buried utility lines; contact local power organizations before digging.
6. Tipping/crushing hazard—lower the cutter head when operating on slopes.
7. Explosion hazard, fueling—stop the engine and extinguish all flames when fueling.
8. Warning—lower the grinder head, set the parking brake (if applicable), stop the engine, remove the ignition key before leaving the machine.



121-4382

1. Read the *Operator's Manual* for information on operating the grinder—1) Grind horizontally along the edge of the stump; 2) Lower the grinder slightly into the stump; 3) Grind horizontally down to ground level; 4) Move the grinder forward.
2. Do not start grinding in the middle of the stump; start grinding at the edge of the stump.
3. 1) To power the grinder, press the safety lock and the trigger together; 2) To keep the grinder running, hold the trigger.

Setup

Checking Fluid Levels

Before starting the engine for the first time, check the engine oil and hydraulic fluid levels; refer to [Checking the Engine-oil Level \(page 24\)](#) and [Checking the Hydraulic-fluid Level \(page 36\)](#) for more information.

Charging the Battery

Charge the battery; refer to [Charging the Battery \(page 30\)](#) for more information.

Opening the Lift Valve

Before you can raise the grinder and move the machine, you must open the lift valve located under the control panel ([Figure 4](#)). Turn the knob counter clockwise to allow you to lift the grinder. The further you turn the knob, the faster the head will raise and lower when activated.

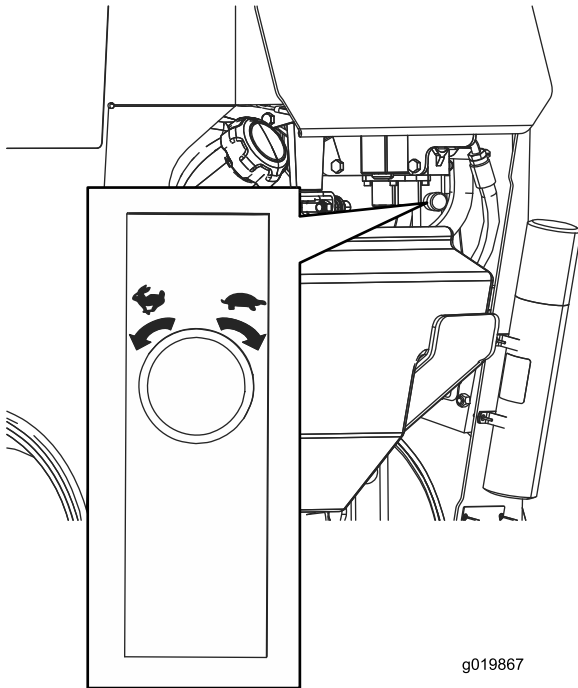

Figure 4

g019867

Product Overview

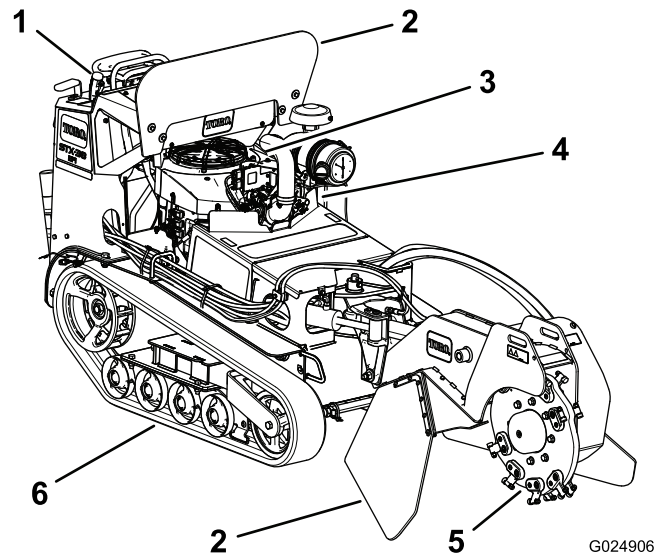

Figure 5

- | | | |
|------------------|------------|------------|
| 1. Control panel | 3. Engine | 5. Grinder |
| 2. Chip shield | 4. Battery | 6. Track |

G024906

Controls

Become familiar with all the controls ([Figure 6](#)) before you start the engine and operate the machine.

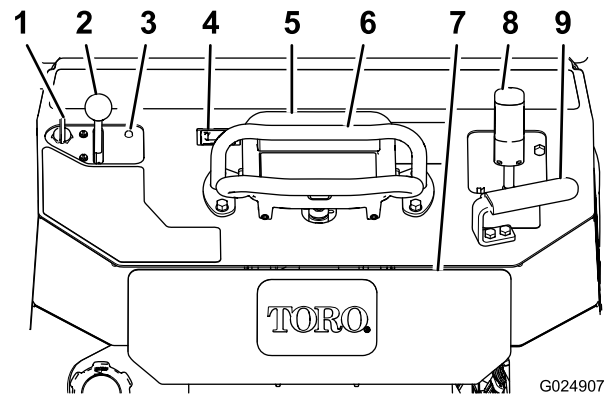

Figure 6

- | | |
|---------------------------|--------------------------|
| 1. Key switch | 6. Reference bar |
| 2. Throttle lever | 7. Reverse safety plate |
| 3. Engine indicator light | 8. Grinder control lever |
| 4. Hour meter | 9. Handle |
| 5. Traction control | |

G024907

Key Switch

The key switch has three positions: Off, Run, and Start.

- To start the engine, rotate the key to the Start position. Release the key when engine starts and it will move automatically to the Run position.
- To stop the engine, rotate the key to the Off position.

Throttle Lever

Move the control forward to increase the engine speed and rearward to decrease speed.

Hour Meter

When the engine is off, the hour meter displays the number of hours of operation that have been logged on the machine.

Reference Bar

When driving the machine, use the reference bar as a handle and a leverage point for controlling the traction control. To ensure smooth, controlled operation, do not take both hands off the reference bar while operating the machine.

Parking Brake

To engage the parking brake, lift the lever upward. To disengage the parking brake, push the lever downward.

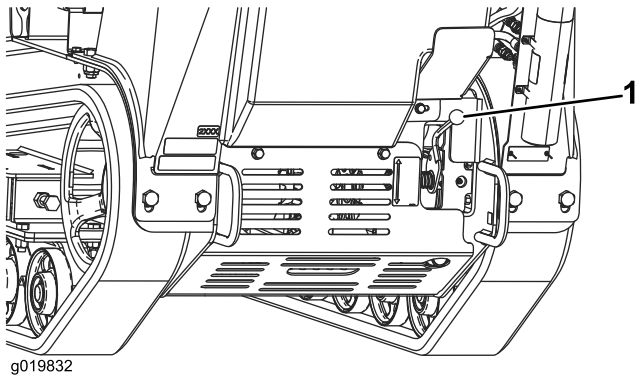

Figure 7

1. Parking-brake lever

Traction Control

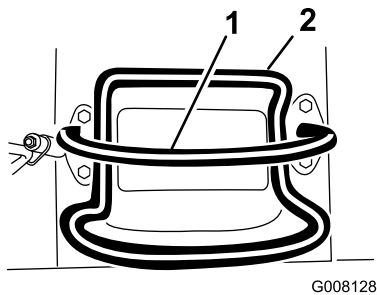

Figure 8

1. Reference bar (does not move to give you a reference point and a fixed handle to hold while operating the traction unit)
2. Traction control (moves to control the machine)

- To move forward, move the traction control forward (Figure 9).

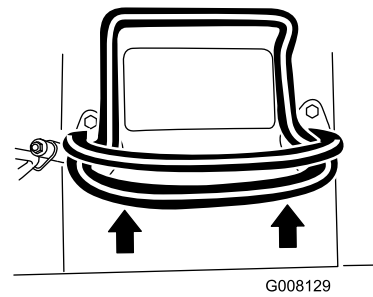

Figure 9

- To move rearward, move the traction control rearward (Figure 10). **When reversing, look behind for obstructions and keep your hands on the reference bar (Figure 8).**

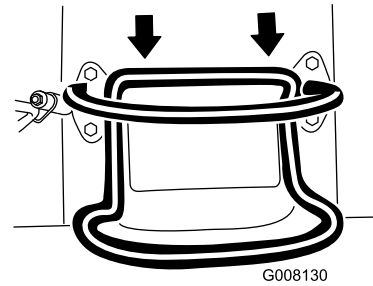

Figure 10

- To turn right, rotate the traction control clockwise (Figure 11).

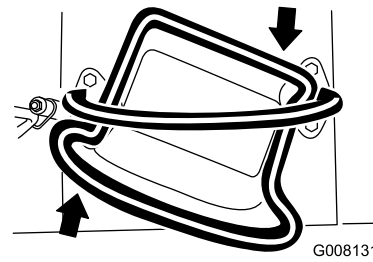

Figure 11

- To turn left, rotate the traction control counterclockwise (Figure 12).

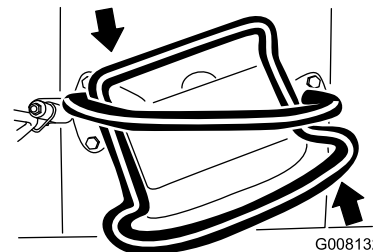

Figure 12

- To stop, release the traction control (Figure 8).

Note: The farther you move the traction control in any direction, the faster the machine will move in that direction.

Grinder Control Lever

Operate the grinder using the grinder control lever as follows:

- To start the grinder (Figure 13), press the red button on the top of the lever, then squeeze the trigger. Once the grinder has started, you can release the red button.
- To stop the grinder (Figure 13), release the trigger for more than a half second.

Note: If you are operating the grinder and momentarily release the trigger (for less than a half second) the grinder will continue operation.

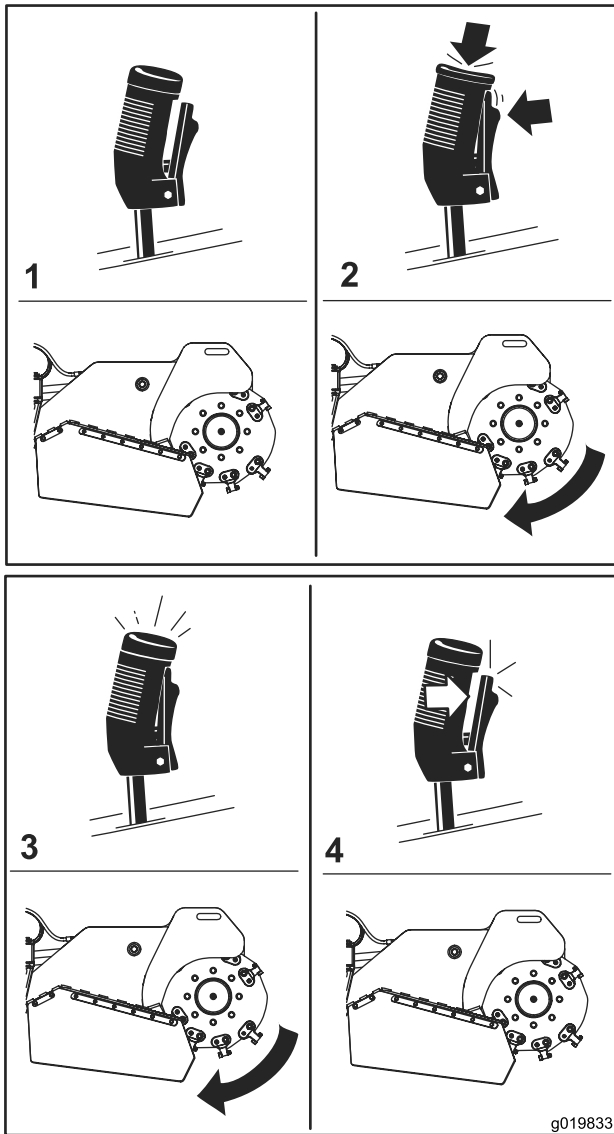

Figure 13

- | | |
|----------------------|---------------------|
| 1. Neutral | 3. Run the grinder |
| 2. Start the grinder | 4. Stop the grinder |

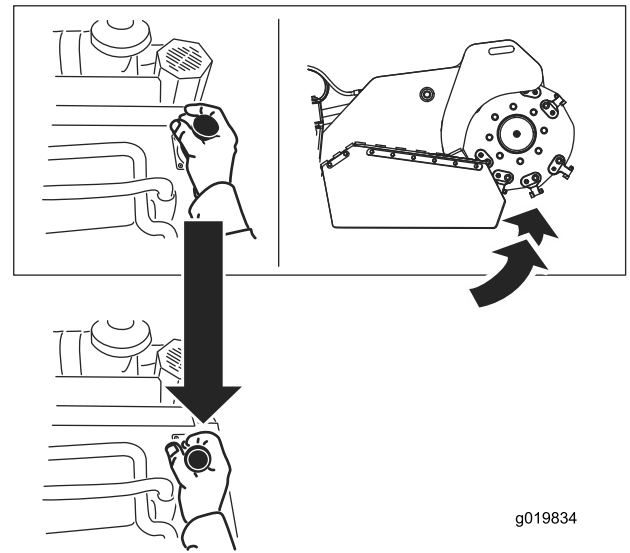

Figure 14

- To lower the grinder, push the lever forward (Figure 15).

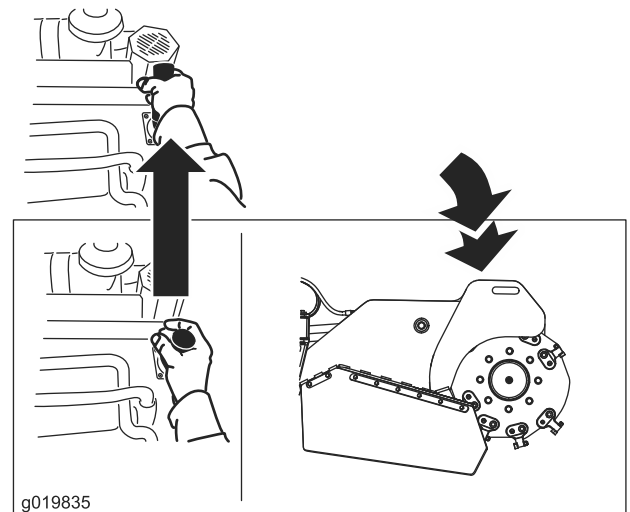

Figure 15

- To rotate the grinder to the right or left, move the lever in the desired direction.

- To raise the grinder, pull the lever rearward (Figure 14).

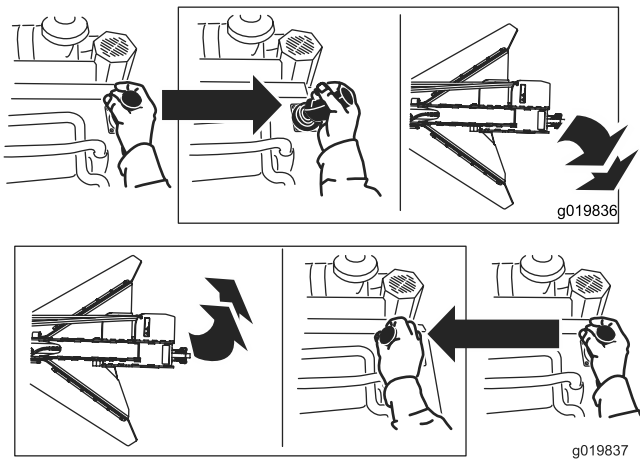

Figure 16

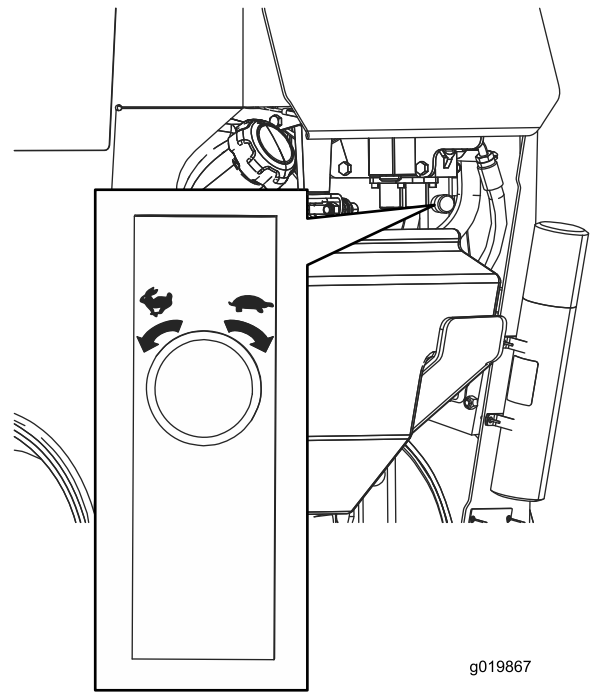

Figure 17

Lift/Lower Speed Control

You can change how quickly the grinder head raises and lowers using the lift/lower speed control, located under the right side of the control panel (Figure 17). Rotate the dial counter clockwise to increase the speed or clockwise to reduce the speed.

If you ever need to stop the machine with the grinder head raised, turn the control dial all the way clockwise to lock the grinder head before leaving the machine or performing any maintenance

CAUTION

If you leave the grinder head in the Up position without turning the lift/lower speed control dial all the way clockwise, the grinder could lower crushing you or bystanders.

Whenever possible, lower the grinder to the ground before stopping the engine. If you must keep the grinder head raised, turn the lift/lower speed control dial all the way clockwise to lock the grinder.

Specifications

Note: Specifications and design are subject to change without notice.

Width	86 cm (34 inches)
Length	241 cm (95 inches)
Height	130 cm (51 inches)
Weight	794 kg (1750 lb)

Attachments/Accessories

A selection of Toro approved attachments and accessories is available for use with the machine to enhance and expand its capabilities. Contact your Authorized Service Dealer or Distributor or go to www.Toro.com for a list of all approved attachments and accessories.

Operation

Note: Determine the left and right sides of the machine from the normal operating position.

Important: Before operating, check the fuel and oil level, and remove debris from the machine. Also, ensure that the area is clear of people and debris. You should also know and have marked the locations of all utility lines.

Adding Fuel

Recommended Fuel:

- For best results, use only clean, fresh (less than 30 days old), unleaded gasoline with an octane rating of 87 or higher ((R+M)/2 rating method).
- Ethanol: Gasoline with up to 10% ethanol (gasohol) or 15% MTBE (methyl tertiary butyl ether) by volume is acceptable. Ethanol and MTBE are not the same. Gasoline with 15% ethanol (E15) by volume is not approved for use. **Never use** gasoline that contains more than 10% ethanol by volume, such as E15 (contains 15% ethanol), E20 (contains 20% ethanol), or E85 (contains 85% ethanol). Using unapproved gasoline may cause performance problems and/or engine damage which may not be covered under warranty.
- **Do not** use gasoline containing methanol.
- **Do not** store fuel either in the fuel tank or fuel containers over the winter unless a fuel stabilizer is used
- **Do not** add oil to gasoline.

⚠ DANGER

In certain conditions, gasoline is extremely flammable and highly explosive. A fire or explosion from gasoline can burn you and others and can damage property.

- Fill the fuel tank outdoors, in an open area, when the engine is cold. Wipe up any gasoline that spills.
- Never fill the fuel tank inside an enclosed trailer.
- Do not fill the fuel tank completely full. Add gasoline to the fuel tank until the level is 6 to 13 mm (1/4 to 1/2 inch) below the bottom of the filler neck. This empty space in the tank allows gasoline to expand.
- Never smoke when handling gasoline, and stay away from an open flame or where gasoline fumes may be ignited by a spark.
- Store gasoline in an approved container and keep it out of the reach of children. Never buy more than a 30-day supply of gasoline.
- Do not operate without entire exhaust system in place and in proper working condition.

⚠ DANGER

In certain conditions during fueling, static electricity can be released causing a spark which can ignite the gasoline vapors. A fire or explosion from gasoline can burn you and others and can damage property.

- Always place gasoline containers on the ground away from your vehicle before filling.
- Do not fill gasoline containers inside a vehicle or on a truck or trailer bed because interior carpets or plastic truck-bed liners may insulate the container and slow the loss of any static charge.
- When practical, remove gas-powered equipment from the truck or trailer and fuel the equipment with the wheels on the ground.
- If this is not possible, then fuel such equipment on a truck or trailer from a portable container, rather than from a gasoline-dispenser nozzle.
- If a gasoline-dispenser nozzle must be used, keep the nozzle in contact with the rim of the fuel tank or container opening at all times until fueling is complete.

Important: Do not use methanol, gasoline containing methanol, or gasohol containing more than 10% ethanol because the fuel system could be damaged. Do not mix oil with gasoline.

Using Stabilizer/Conditioner

Use a fuel stabilizer/conditioner in the machine to keep gasoline fresh during storage of 90 days or less. For longer storage it is recommended that the fuel tank be drained.

Important: Do not use fuel additives containing methanol or ethanol.

Add the correct amount of gas stabilizer/conditioner to the gas.

Note: A fuel stabilizer/conditioner is most effective when mixed with fresh gasoline. To minimize the chance of varnish deposits in the fuel system, use fuel stabilizer at all times.

Filling the Fuel Tank

1. Park the machine on a level surface, lower the grinder, and stop the engine.
2. Remove the key and allow the engine to cool.
3. Clean around the fuel tank cap and remove it (Figure 18).

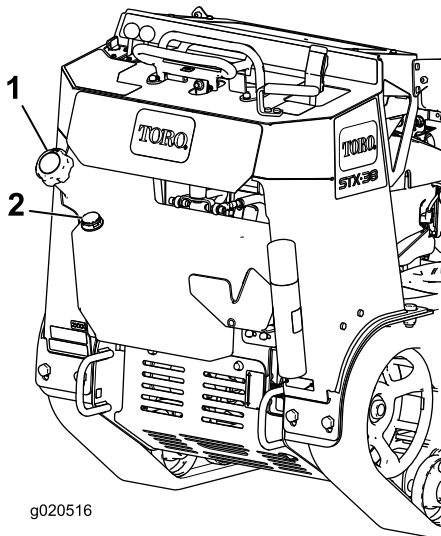

Figure 18

1. Fuel-tank cap
2. Fuel gauge

4. Add unleaded gasoline to the fuel tank until the level is 6 to 13 mm (1/4 to 1/2 inch) below the bottom of the filler neck.

Important: This space in the tank allows gasoline to expand. Do not fill the fuel tank completely full.

5. Install the fuel-tank cap securely.
6. Wipe up any gasoline that may have spilled.

Checking the Engine-oil Level

Before you start the engine and use the machine, check the oil level in the engine crankcase; refer to [Checking the Engine-oil Level](#) (page 24).

Starting and Stopping the Engine

Starting the Engine

1. Move the throttle lever midway between the Slow and Fast positions (Figure 19).

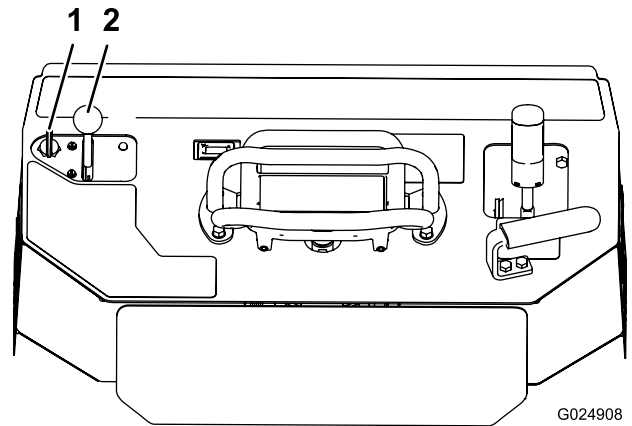

Figure 19

1. Key
2. Throttle lever

2. Turn the key to the On position (Figure 19). When the engine starts, release the key.

Important: Do not engage the starter for more than 10 seconds at a time. If the engine fails to start, allow a 30 second cool-down period between attempts. Failure to follow these instructions can burn out the starter motor.

3. Move the throttle lever to the desired setting (Figure 19).

Important: If the engine is run at high speeds when the hydraulic system is cold (i.e., when the ambient air temperature is near freezing or lower), hydraulic system damage could occur. When starting the engine in cold conditions, allow the engine to run in the middle throttle position for 2 to 5 minutes before moving the throttle to fast (rabbit). At normal to high ambient temperatures, run the machine at full throttle for the best performance and cooling.

Note: If the outdoor temperature is below freezing, store the machine in a garage to keep it warmer and aid in starting.

Stopping the Engine

1. Stop the grinder and lower it to the ground.
2. Move the throttle lever to the Slow position (Figure 19).
3. Turn the key to the Off position (Figure 19).

Note: If the engine has been working hard or is hot, let it idle for a minute before turning the ignition key

off. This helps cool the engine before it is stopped. In an emergency, the engine may be stopped immediately.

4. Remove the key.

Stopping the Machine

To stop the machine, release the traction control, move the throttle lever to slow (turtle), lower the grinder to the ground, stop the engine, and remove the key.

⚠ CAUTION

A child or untrained bystander could attempt to operate the machine and be injured.

Remove the key from the switch when leaving the machine, even if just for a few seconds.

Moving a Non-functioning Machine

Important: Do not tow or pull the machine without first opening the tow valves, or the hydraulic system will be damaged.

1. Stop the engine.
2. Remove the bottom shield.
3. Using a wrench, turn the tow valves on the hydraulic motors twice counter-clockwise (Figure 20).

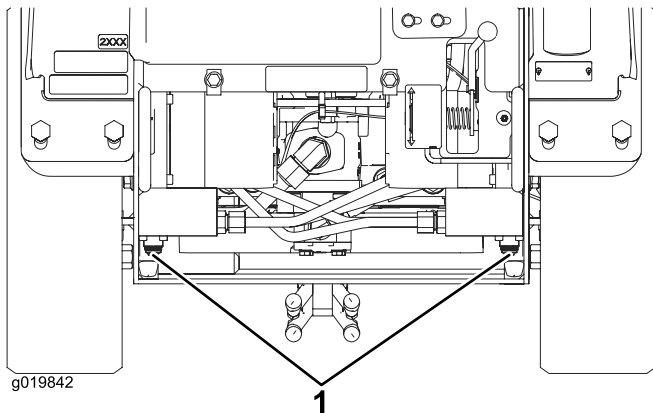

Figure 20

1. Tow valves

4. Install the bottom shield and tow the machine as required.
5. When the machine has been repaired, close the tow valves before operating it.

Grinding a Stump

⚠ DANGER

This product is capable of amputating hands and feet.

- Stay in the operating position while the grinder is running, and keep away from the grinder.
- Keep all bystanders a safe distance from the grinder.
- Stop the grinder immediately if any people or animals enter the work area.

⚠ WARNING

Grinding a stump will throw wood chips, soil, and other debris into the air which could injure you or bystanders.

- Always wear a hard hat and a full face shield when using the grinder.
- Keep all bystanders a safe distance from the grinder.

⚠ WARNING

The grinder is very loud when cutting a stump and can damage your ears.

Always wear hearing protection when using the grinder.

1. Start the engine, raise the grinder, set the throttle lever to the Fast position, and move the machine to the stump to be ground.
2. Use the grinder control lever and the traction control to position the grinder to one side of the front of the stump, about an inch below the top of the stump surface.
3. Start the grinder and wait for it to get up to full speed.
4. Using the grinder control lever, swing the grinder slowly across the face of the stump, cutting away a swath of chips (Figure 21).

Important: The grinder will automatically slow down the speed at which it swings into the stump to maintain the optimum flywheel speed and not bog down in the wood.

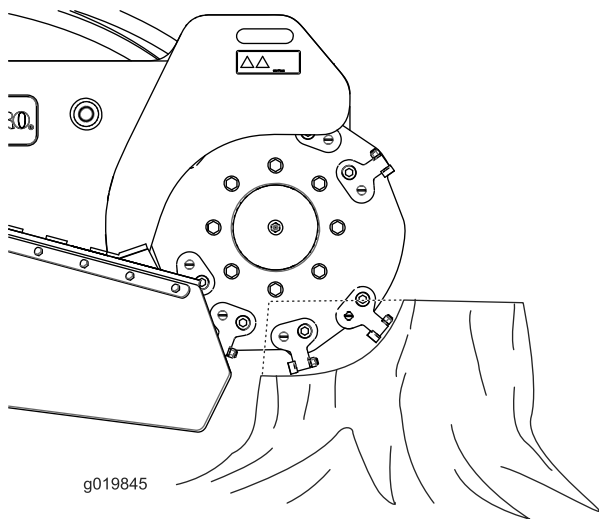

Figure 21

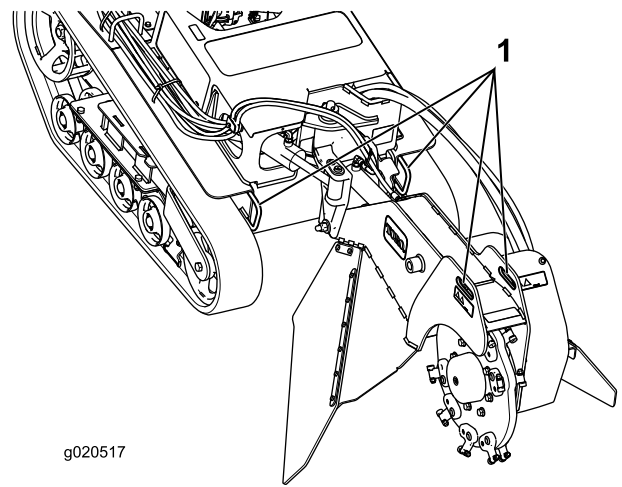

Figure 22

1. Front tie-down loop

5. Lower the grinder about an inch and swing it back over the stump.
6. Repeat step 5 until you have reached ground level.
7. Raise the grinder so that it is about an inch below the top of the remaining stump, move the machine forward a few inches, and repeat steps 4 through 6 until you have ground away the entire stump.
8. If there are any large roots to be ground, position the grinder over each root and use the traction control and grinder control to move the grinder along the root, grinding it away.

Securing the Machine for Transport

When transporting the machine on a trailer, always use the following procedure:

Important: Do not operate or drive the machine on roadways.

1. Stop the engine.
2. Lower the grinder.
3. Secure the machine to the trailer with chains or straps using the tie-down/lift loops at the front and rear of the machine (Figure 22 and Figure 23).

Note: Refer to your local ordinances for trailer and tie-down requirements.

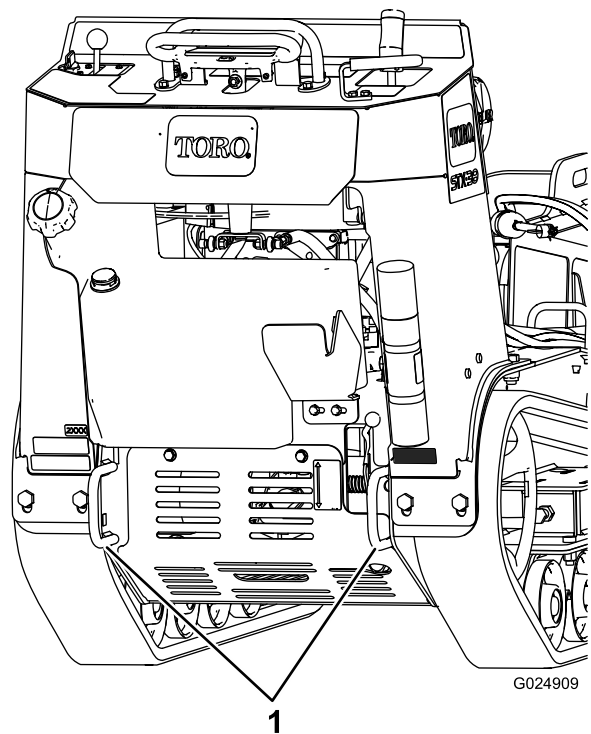

Figure 23

1. Rear tie-down loops

Lifting the Machine

You can lift the machine using the tie-down/lift loops as lift points (Figure 22 and Figure 23).

Operating Tips

- Clean the area of trash, branches and rocks before operating to prevent equipment damage.
- Always use full throttle (maximum engine speed) when grinding.
- Cut the edges of the stump for more efficient grinding. Once your cutting swath is close to 1/4 of the wheel diameter ([Figure 21](#)), lift the grinder, move forward and begin cutting on the edge again.

Maintenance

Note: Determine the left and right sides of the machine from the normal operating position.

Recommended Maintenance Schedule(s)

Maintenance Service Interval	Maintenance Procedure
After the first 50 hours	<ul style="list-style-type: none">• Check and adjust the track tension.
Before each use or daily	<ul style="list-style-type: none">• Grease the machine (grease it immediately after every washing.)• Check the engine-oil level.• Clean the engine screen.• Check the condition of the teeth and rotate or replace any that are worn or damaged.• Remove debris from the machine.• Check for loose fasteners.
After each use	<ul style="list-style-type: none">• Check the condition of and clean the tracks.
Every 25 hours	<ul style="list-style-type: none">• Check the battery electrolyte level.• Check the hydraulic-fluid level.
Every 100 hours	<ul style="list-style-type: none">• Change the engine oil (the oil filter is recommended) (more often in dirty or dusty conditions).• Check and adjust the track tension.• Check the hydraulic lines for leaks, loose fittings, kinked lines, loose mounting supports, wear, weather, and chemical deterioration and repair if necessary.
Every 150 hours	<ul style="list-style-type: none">• Inspect the primary filter.• Replace the low-pressure fuel filter (more often in dirty or dusty conditions).
Every 200 hours	<ul style="list-style-type: none">• Change the engine oil filter.• Replace the hydraulic filter.
Every 250 hours	<ul style="list-style-type: none">• Check and grease the road wheels.
Every 300 hours	<ul style="list-style-type: none">• Replace the primary air filter (more often in dusty or sandy conditions).• Check the inner air filter.
Every 400 hours	<ul style="list-style-type: none">• Change the hydraulic fluid.
Every 600 hours	<ul style="list-style-type: none">• Replace the inner air filter.• Replace and gap the spark plugs.
Every 1,500 hours	<ul style="list-style-type: none">• Replace all moving hydraulic hoses.
Yearly or before storage	<ul style="list-style-type: none">• Check and adjust the track tension.• Touch up chipped paint

Important: Refer to your engine operator's manual for additional maintenance procedures.

⚠ CAUTION

If you leave the key in the ignition switch, someone could accidentally start the engine and seriously injure you or other bystanders.

Remove the key from the ignition and disconnect the wire from the spark plug before you do any maintenance. Set the wire aside so that it does not accidentally contact the spark plug.

Premaintenance Procedures

Before opening any of the covers, stop the engine, remove the key, and allow the engine to cool.

Removing the Front Cover

1. Lower the grinder, stop the engine, remove the key, and allow the machine to cool.

⚠ WARNING

If the machine has been running, both the cover and the muffler under the cover will be hot and can cause severe burns if you touch them.

Allow the machine to cool before removing the cover.

- Loosen the 2 screws securing the front cover to the machine (Figure 24).

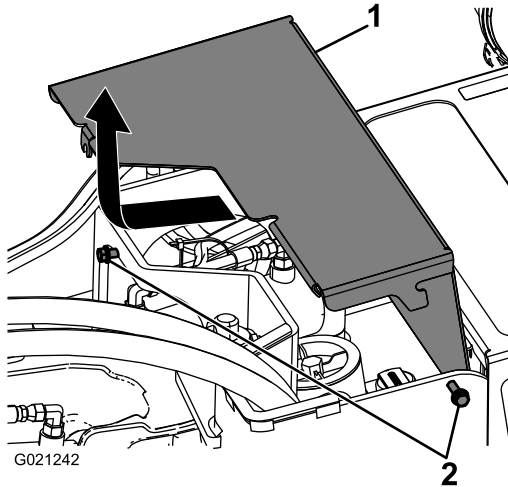

Figure 24

- Cover
- Screws

- Slide the cover forward slightly and pull up to remove the cover (Figure 24).

Installing the Front Cover

- Lower the grinder, stop the engine, and remove the key.
- Slide the front cover into place and tighten the 2 screws securing it to the machine (Figure 24).

Removing the Bottom Shield

- Lower the grinder, stop the engine, and remove the key.
- Loosen the 2 bolts securing the bottom shield sequentially until the shield is free (Figure 25).

Important: The fasteners on the bottom shield are designed to remain on the cover after removal. Loosen both bolts a few turns so that the shield is loose but still attached, then go back and loosen them until the shield comes free. This prevents you from accidentally stripping the bolts free of the retainers.

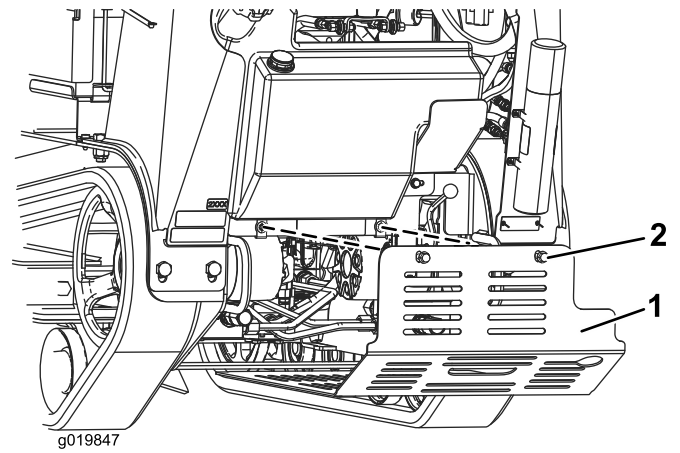

Figure 25

- Bottom shield
- Bolts

- Pull the shield back and out of the machine.

Installing the Bottom Shield

- Lower the grinder, stop the engine, and remove the key.
- Slide the bottom shield into the machine (Figure 25).

Note: You may need to lift up on the bottom shield to ensure that it seats correctly.

- Secure the shield with the bolts that you loosened previously.

Lubrication

Greasing the Machine

Service Interval: Before each use or daily (grease it immediately after every washing.)

Grease Type: General-purpose grease

1. Lower the grinder, stop the engine, and remove the key.
2. Clean the grease fittings with a rag.
3. Connect a grease gun to each fitting (Figure 26 through Figure 28).
4. Pump grease into the fittings until grease begins to ooze out of the bearings (approximately 3 pumps).
5. Wipe up any excess grease.

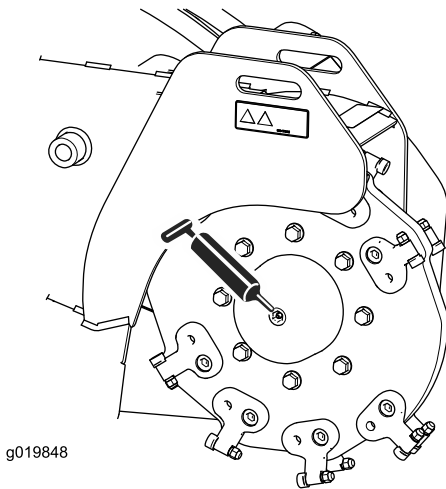

Figure 26

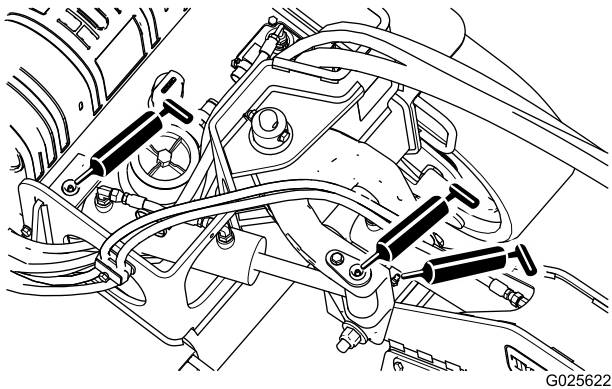

Figure 27

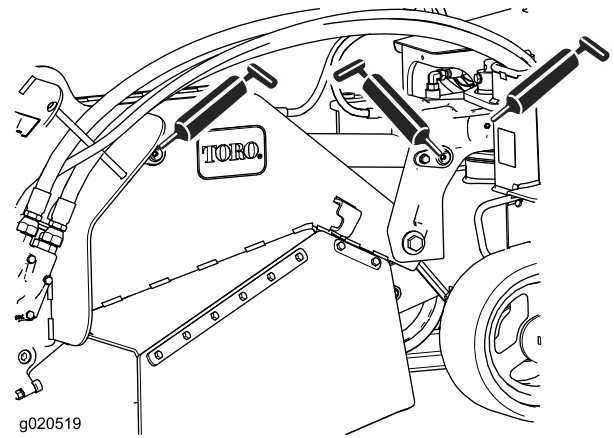

Figure 28

Engine Maintenance

Servicing the Air Cleaner

Service Interval: Every 150 hours—Inspect the primary filter.

Every 300 hours/Yearly (whichever comes first)—Replace the primary air filter (more often in dusty or sandy conditions).

Every 300 hours—Check the inner air filter.

Every 600 hours—Replace the inner air filter.

Note: Check the filters more frequently if the operating conditions are extremely dusty or sandy.

Removing the Filters

1. Lower the grinder and stop the engine.
2. Remove the key.
3. Release the latches on the air cleaner and pull the air-cleaner cover off the air-cleaner body (Figure 29).

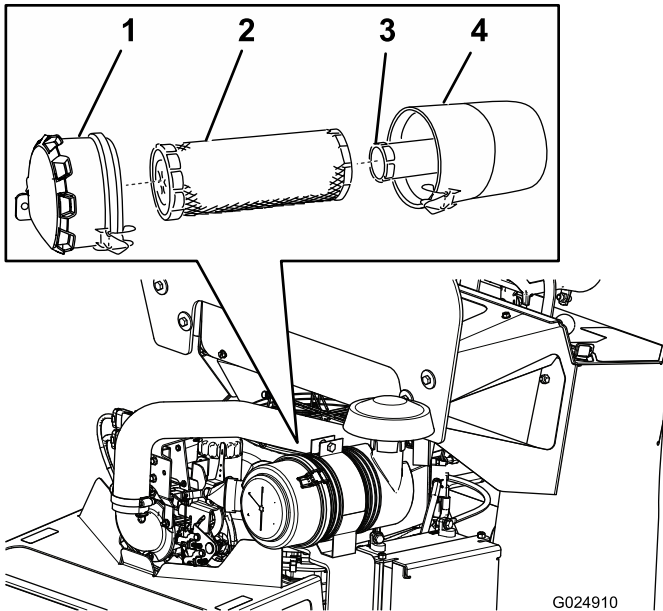

Figure 29

1. Air-cleaner cover
2. Primary filter
3. Inner filter
4. Air-cleaner body

4. Clean the inside of the air-cleaner cover with compressed air.
5. Gently slide the primary filter out of the air-cleaner body (Figure 29).

Note: Avoid knocking the filter into the side of the body.

6. Remove the inner filter only if you intend to replace it.

Important: Never attempt to clean the inner filter. If the inner filter is dirty, then the primary filter is damaged. Replace both filters.

7. Inspect the primary filter for damage by looking into the filter while shining a bright light on the outside of the filter. Holes in the filter will appear as bright spots. If the filter is damaged, discard it.

Installing the Filters

Important: To prevent engine damage, always operate the engine with both air filters and the cover installed.

1. If installing new filters, check each filter for shipping damage.

Note: Do not use a damaged filter.

2. If the inner filter is being replaced, carefully slide it into the filter body (Figure 29).
3. Carefully slide the primary filter over the inner filter (Figure 29).

Note: Ensure that the primary filter is fully seated by pushing on its outer rim while installing it.

Important: Do not press on the soft inside area of the filter.

4. Slide the cover onto the air-cleaner body and secure it with the latches (Figure 29).

Servicing the Engine Oil

Oil Type: Detergent oil (API service class SJ or higher)

Oil Capacity: with a filter change, 2.9 L (3.06 US qt)

Viscosity: Refer to the following table:

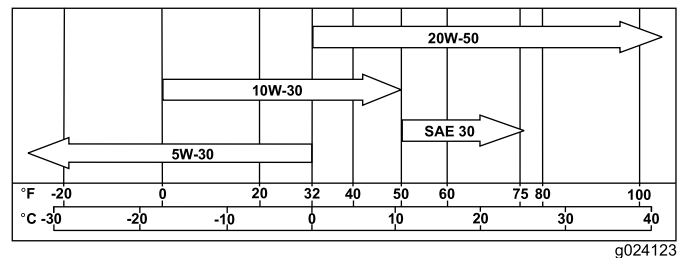

Figure 30

Toro Premium Engine Oil is available from your Authorized Toro Dealer.

Note: Synthetic oils will provide better starting in extreme cold below -23°C (-10°F).

Checking the Engine-oil Level

Service Interval: Before each use or daily

Note: Check the oil when the engine is cold.

⚠ WARNING

Contact with hot surfaces may cause personal injury.

Keep hands, feet, face, clothing, and other body parts away from the muffler and other hot surfaces.

Important: Do not overfill the crankcase with oil because damage to the engine may result. Do not run engine with oil below the low mark because the engine may be damaged.

1. Lower the grinder and stop the engine. Remove the key.
2. Check the oil as shown in [Figure 31](#).

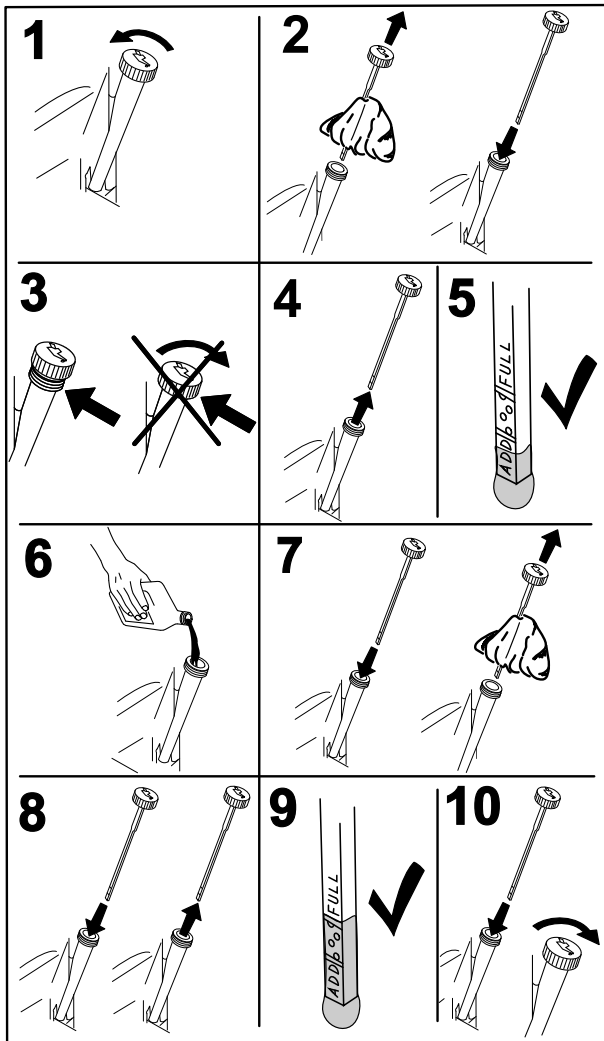

Figure 31

G008792

Changing the Engine Oil

Service Interval: Every 100 hours/Yearly (whichever comes first) (more often in dirty or dusty conditions).

Note: Dispose of the used oil at a recycling center.

1. Start the engine and let it run five minutes. This warms the oil so it drains better.
2. Park the machine so that the rear is slightly lower than the front to ensure the oil drains completely.
3. Lower the grinder and stop the engine. Remove the key.
4. Place a pan below the drain hose. Rotate the oil drain valve to allow oil to drain ([Figure 32](#) and [Figure 33](#)).

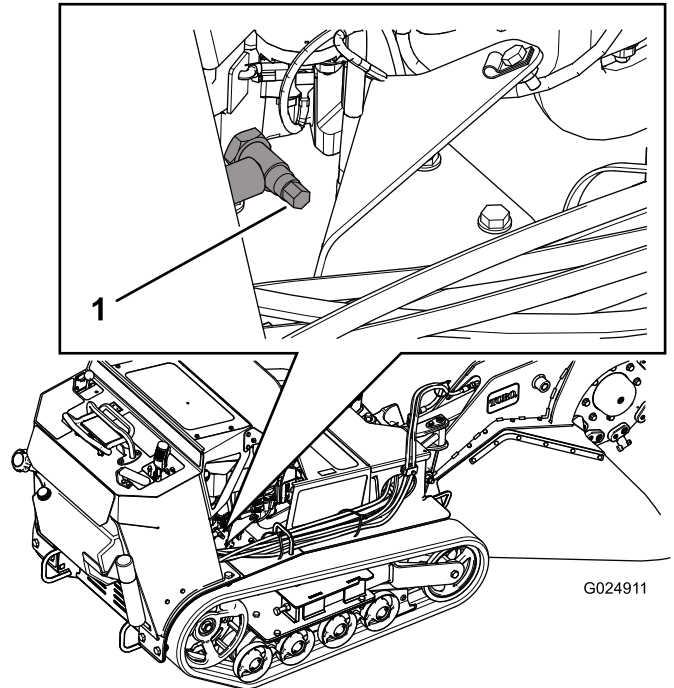

Figure 32

G024911

1. Oil-drain valve

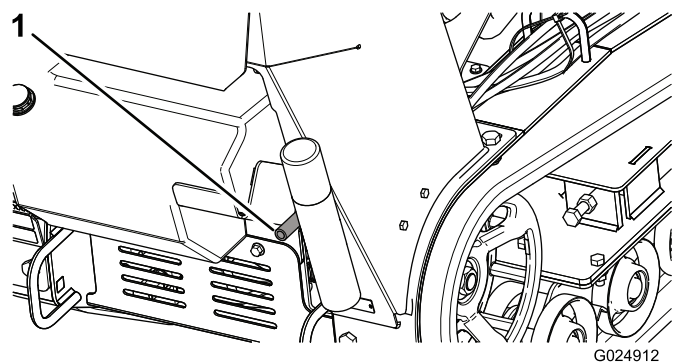

Figure 33

G024912

1. Oil-drain hose

5. When oil has drained completely, close the drain valve.
6. Dispose of the used oil at a recycling center

- Slowly pour approximately 80% of the specified oil into the filler tube and slowly add the additional oil to bring it to the **Full** mark (Figure 34).

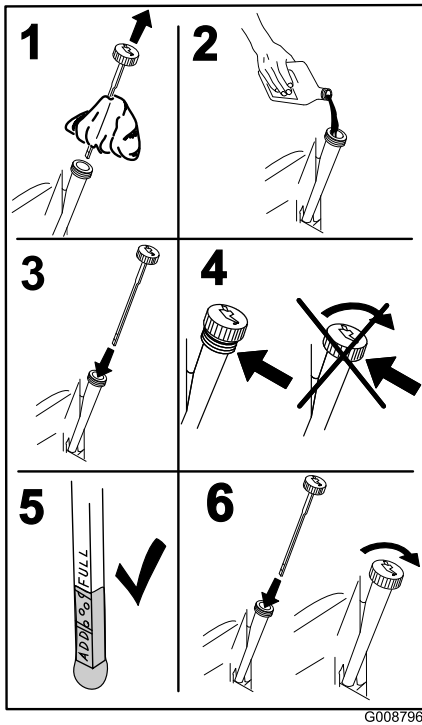

Figure 34

- Start the engine and drive to a flat area. Check the oil level again.

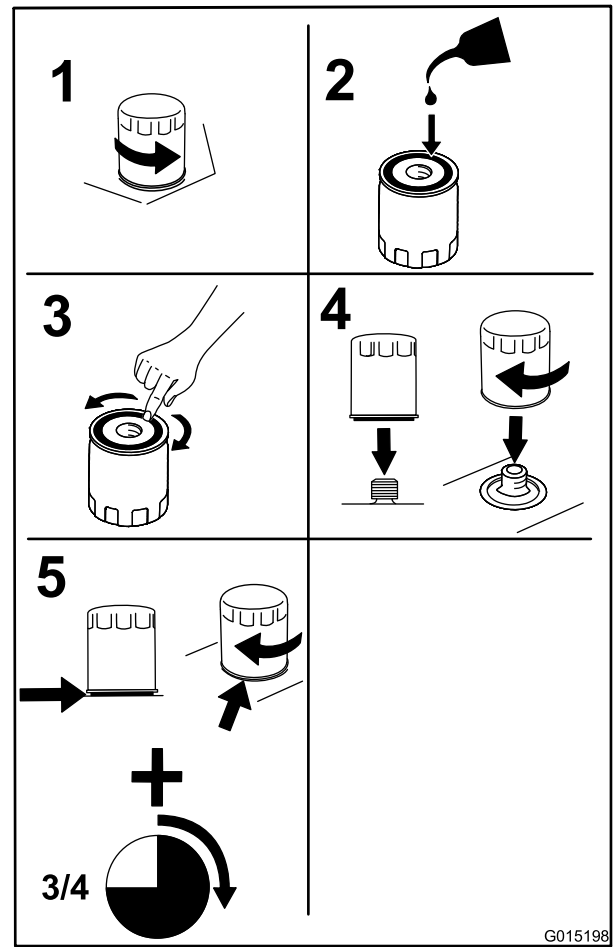

Figure 35

Changing the Engine Oil Filter

Service Interval: Every 200 hours

Note: Change the engine oil filter more frequently when operating conditions are extremely dusty or sandy.

- Clean the area around the oil filter.
- Drain the oil from the engine; refer to [Changing the Engine Oil](#) (page 24).
- Change the engine oil filter as shown in [Figure 35](#).

Important: Thread the oil filter on until the gasket touches the engine and then turn it an extra 3/4 turn.

- Fill the crankcase with the proper type of new oil.

Servicing the Spark Plugs

Service Interval: Every 600 hours—Replace and gap the spark plugs.

Make sure the air gap between the center and side electrodes is correct before installing the spark plugs. Use a spark plug wrench for removing and installing the spark plugs and a gapping tool/feeler gauge to check and adjust the air gap. Install new spark plugs at the indicated interval.

Type : Champion® XC10YC or equivalent

Air Gap: 0.76 mm (0.030 inch)

Removing the Spark Plugs

1. Lower the grinder and stop the engine. Remove the key.
2. Remove each spark plug.

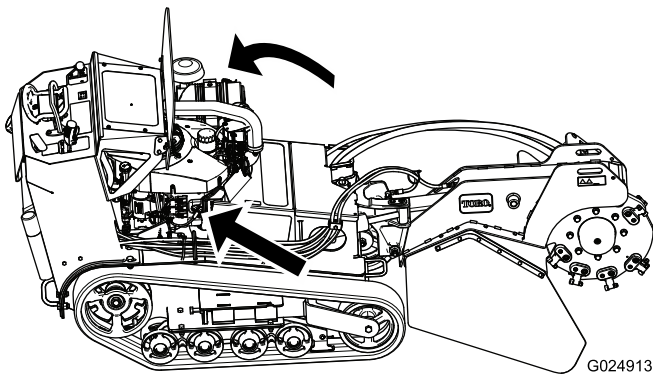

G024913

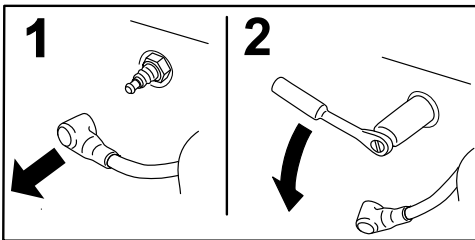

G008791

Figure 36

Setting the Gap on New Spark Plugs

Set the gap in each new spark plug to 0.76 mm (0.030 inch).

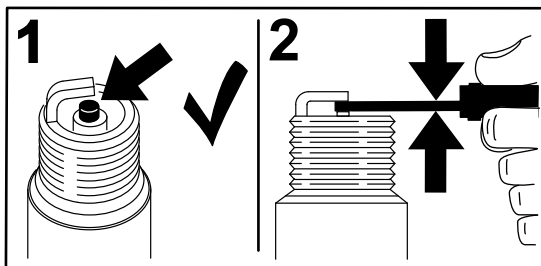

G008794

Figure 37

Installing the Spark Plugs

Tighten the spark plugs to 27 N-m (20 ft-lb).

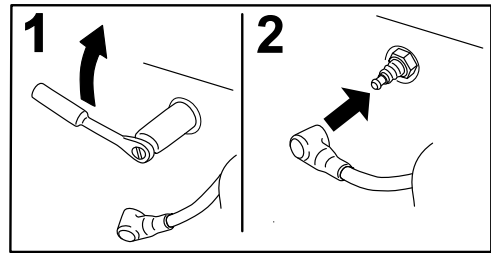

G008795

Figure 38

Fuel System Maintenance

Draining the Fuel Tank

⚠ DANGER

In certain conditions, gasoline is extremely flammable and highly explosive. A fire or explosion from gasoline can burn you and others and can damage property.

- Drain gasoline from the fuel tank when the engine is cold. Do this outdoors in an open area. Wipe up any gasoline that spills.
- Never smoke when draining gasoline, and stay away from an open flame or where a spark may ignite the gasoline fumes.

1. Park the machine on a level surface, to ensure that the fuel tank drains completely.
2. Lower the grinder.
3. Stop the engine, remove the key, and wait for all moving parts to stop before leaving the operating position.
4. Remove the bottom shield; refer to [Removing the Bottom Shield](#) (page 21).
5. Turn the fuel-shutoff valve ([Figure 39](#)) to the closed position.

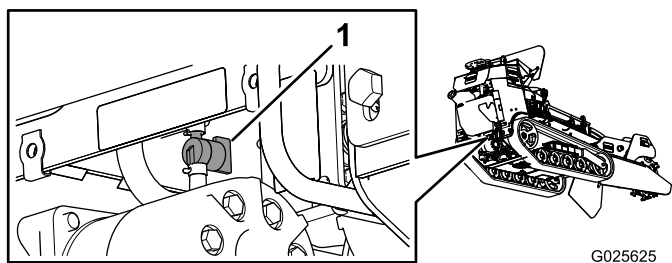

Figure 39

1. Fuel-shutoff valve

6. Squeeze the ends of the hose clamp on the engine side of the shut-off valve together and slide it up the fuel line away from valve.
7. Pull the fuel line off the valve. Open the fuel-shutoff valve and allow the gasoline to drain into a gas can or drain pan.

Note: Now is the best time to install a new fuel filter, because the fuel tank is empty. Refer to [Replacing the Low-pressure Fuel Filter](#) (page 27).

8. Install the fuel line onto the fuel-shutoff valve. Slide the hose clamp close to the valve to secure the fuel line.
9. Install the bottom shield; refer to [Installing the Bottom Shield](#) (page 21).

10. Wipe up any spilled fuel.

Note: The fuel-shutoff valve is also accessible through the frame, behind the battery ([Figure 40](#)).

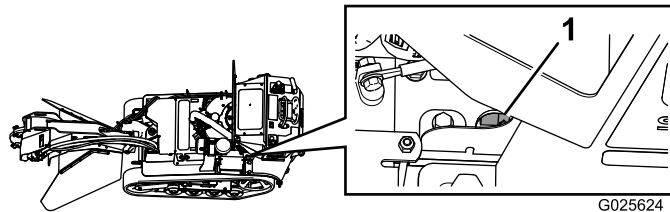

Figure 40

1. Fuel-shutoff valve

Replacing the Low-pressure Fuel Filter

Service Interval: Every 150 hours/Yearly (whichever comes first) (more often in dirty or dusty conditions).

Never install a dirty filter if it is removed from the fuel line.

Note: Note how the fuel filter is installed in order to install the new filter correctly.

Note: Wipe up any spilled fuel.

1. Lower the grinder.
2. Stop the engine, remove the key, and wait for all moving parts to stop before leaving the operating position.
3. Turn the fuel-shutoff valve to the closed position.
4. Squeeze the ends of the hose clamps together and slide them away from the filter ([Figure 41](#)).

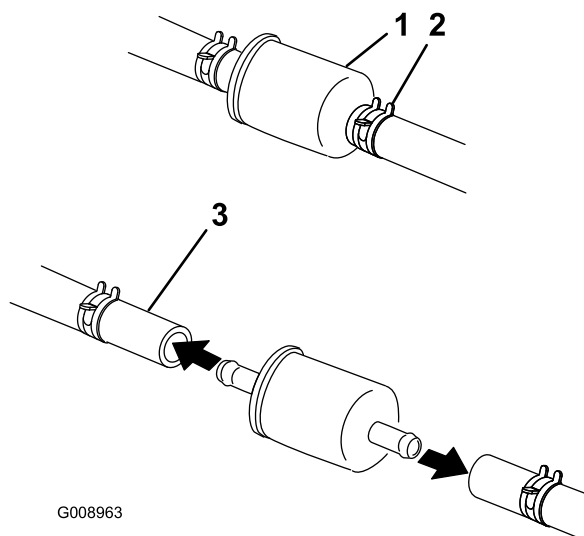

Figure 41

1. Fuel filter
2. Hose clamp
3. Fuel line

5. Remove the filter from the fuel lines.

6. Install a new filter and move the hose clamps close to the filter.
7. Turn the fuel-shutoff valve to the open position.
8. Check for fuel leaks and repair if needed.
9. Wipe up any spilled fuel.

Servicing the High-pressure Fuel Filter

Do not attempt to service the high-pressure fuel filter.

The high-pressure filter is integrated within the fuel-pump module. The fuel filter and other components inside the fuel-pump module are not serviceable. Do not attempt to open the fuel-pump module.

Ensure that an Authorized Service Dealer replaces the fuel-pump module with the high-pressure fuel filter.

Electrical System Maintenance

Servicing the Battery

Service Interval: Every 25 hours—Check the battery electrolyte level.

Always keep the battery clean and fully charged. Use a paper towel to clean the battery case. If the battery terminals are corroded, clean them with a solution of four parts water and one part baking soda. Apply a light coating of grease to the battery terminals to prevent corrosion.

Voltage: 12 V with 280 cold cranking amps at -18C (0°F).

⚠ WARNING

CALIFORNIA

Proposition 65 Warning

Battery posts, terminals, and related accessories contain lead and lead compounds, chemicals known to the State of California to cause cancer and reproductive harm.

Wash hands after handling.

⚠ DANGER

Battery electrolyte contains sulfuric acid which is a deadly poison and causes severe burns.

Do not drink electrolyte and avoid contact with skin, eyes or clothing. Wear safety glasses to shield your eyes and rubber gloves to protect your hands.

Removing the Battery

⚠ WARNING

Battery terminals or metal tools could short against metal machine components causing sparks. Sparks can cause the battery gasses to explode, resulting in personal injury.

- When removing or installing the battery, do not allow the battery terminals to touch any metal parts of the machine.
- Do not allow metal tools to short between the battery terminals and metal parts of the machine.

⚠ WARNING

Incorrect battery cable routing could damage the machine and cables causing sparks. Sparks can cause the battery gasses to explode, resulting in personal injury.

- Always disconnect the negative (black) battery cable before disconnecting the positive (red) cable.
- Always connect the positive (red) battery cable before connecting the negative (black) cable.

1. Lower the grinder.
2. Stop the engine, remove the key, and wait for all moving parts to stop before leaving the operating position.
3. Lift the black rubber cover on the negative cable. Disconnect the negative battery cable from the negative (-) battery terminal (Figure 42).

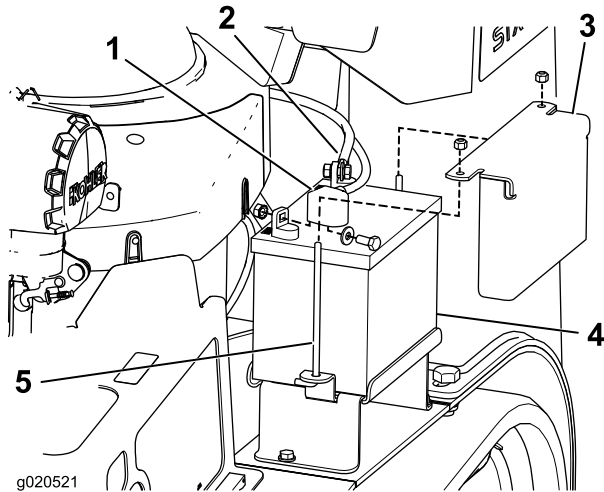

Figure 42

1. Negative cable (rubber cover shown on)
2. Positive cable (rubber cover shown off)
3. Battery hold-down plate
4. Battery
5. J-bolt

Installing the Battery

1. Place the battery onto the machine (Figure 42).
2. Secure the battery with the hold down plate, j-bolts, and locknuts.
3. First, install the positive (red) battery cable to positive (+) battery terminal with a nut, washer and bolt (Figure 42). Slide the rubber cover over the post.

4. Then install the negative battery cable and ground wire to the negative (-) battery terminal with a nut, washer and bolt (Figure 42). Slide the rubber cover over the post.

Checking the Battery Electrolyte Level

⚠ DANGER

Battery electrolyte contains sulfuric acid which is a deadly poison and causes severe burns.

- Do not drink electrolyte and avoid contact with skin, eyes or clothing. Wear safety glasses to shield your eyes and rubber gloves to protect your hands.
- Fill the battery where clean water is always available for flushing the skin.

1. Look at the side of the battery. The electrolyte must be up to the **upper line** (Figure 43). Do not allow the electrolyte to fall below the **Lower line** (Figure 43).

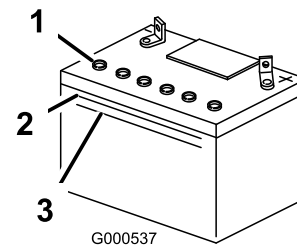

Figure 43

1. Vent caps
2. Upper line
3. Lower line

2. If the electrolyte is low, add the required amount of distilled water; refer to Adding Water to the Battery.

Adding Water to the Battery

The best time to add distilled water to the battery is just before you operate the machine. This lets the water mix thoroughly with the electrolyte solution.

1. Remove the battery from the machine; refer to Removing the Battery.

Important: Never fill the battery with distilled water while the battery is installed in the machine. Electrolyte could be spilled on other parts and cause corrosion.

2. Clean the top of the battery with a paper towel.
3. Remove the vent caps from the battery (Figure 43).
4. Slowly pour distilled water into each battery cell until the electrolyte level is up to the Upper line (Figure 43) on the battery case.

Important: Do not overfill the battery because electrolyte (sulfuric acid) can cause severe corrosion and damage to the chassis.

- Wait five to ten minutes after filling the battery cells. Add distilled water, if necessary, until the electrolyte level is up to the Upper line (Figure 43) on the battery case.
- Install the battery vent caps.

Charging the Battery

⚠ WARNING

Charging the battery produces gasses that can explode.

Never smoke near the battery and keep sparks and flames away from battery.

Important: Always keep the battery fully charged (1.265 specific gravity). This is especially important to prevent battery damage when the temperature is below 32°F (0°C).

- Remove the battery from the chassis; refer to Removing the Battery.
- Check the electrolyte level; refer to Checking the Electrolyte Level.
- Make sure the filler caps are installed in battery. Connect a 3 to 4 amp battery charger to the battery posts. Charge the battery at a rate of 3 to 4 amperes for 4 to 8 hours (12 volts). **Do not overcharge the battery.**
- When the battery is fully charged, unplug the charger from the electrical outlet, then disconnect the charger leads from the battery posts (Figure 44).
- Install the battery onto the machine and connect the battery cables, refer to Installing the Battery.

Note: Do not run the machine with the battery disconnected, electrical damage may occur.

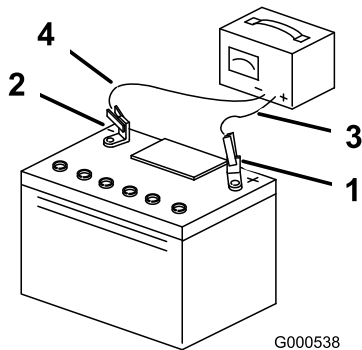

Figure 44

- | | |
|--------------------------|---------------------------|
| 1. Positive Battery Post | 3. Red (+) Charger Lead |
| 2. Negative Battery Post | 4. Black (-) Charger Lead |

Replacing the Fuses

There are 4 fuses in the electrical system. They are under the control panel on the left side (Figure 45).

Start Circuit	30 amp
Not used	25 amp
Cooler fan Circuit	20 amp
Headlight (optional)	15 amp

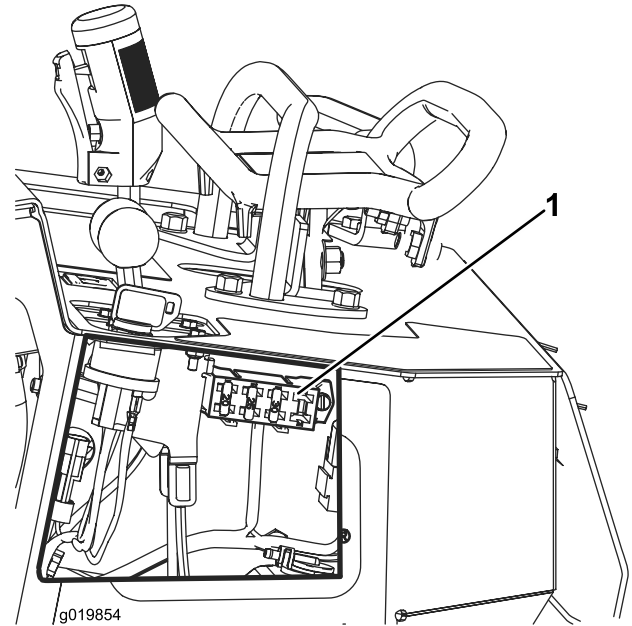

Figure 45

- Fuse block

Drive System Maintenance

Servicing the Tracks

Cleaning the Tracks

Service Interval: After each use

Check the tracks for excessive wear and clean them periodically. If the tracks are worn, replace them.

1. Lower the grinder.
2. Stop the engine, remove the key, and wait for all moving parts to stop before leaving the operating position.
3. Using a water hose or pressure washer, remove dirt from each track system.

Important: Ensure that you use high-pressure water to wash only the track area. Do not use a high-pressure washer to clean the rest of the machine. High-pressure washing can damage the electrical system and hydraulic valves or deplete grease.

Important: Ensure that you fully clean the wheels and the drive sprocket (Figure 46).

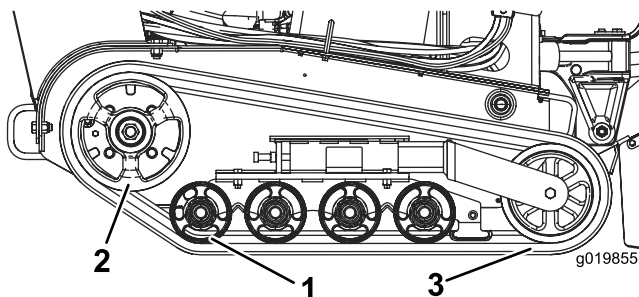

Figure 46

1. Road wheels
2. Drive sprocket
3. Track

Checking and Adjusting the Track Tension

Service Interval: After the first 50 hours

Every 100 hours

To check the tension of each track, place 45 lb (20.4 kg) on the track midway between the front road wheel and the drive sprocket. The track should flex no more than 1/4 to 3/8 inch (0.6 to 1 cm); refer to Figure 47. If it does, adjust the track tension using the following procedure:

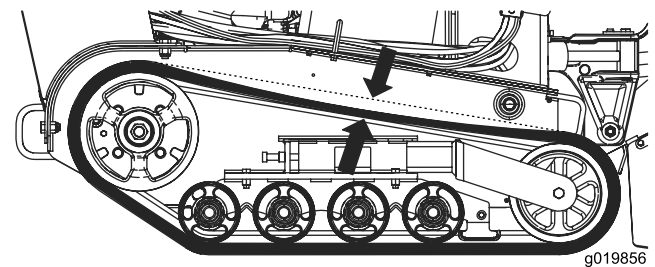

Figure 47

1. Stop the machine in on a level surface.
2. Stop the engine, lower the grinder, remove the key, and wait for all moving parts to stop before leaving the operating position.
3. Loosen the jam nut on the track tensioning bolt (Figure 48).

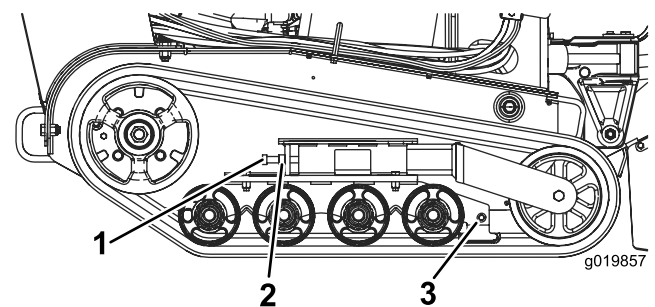

Figure 48

1. Tensioning bolt
2. Jam nut
3. Clamp bolts

4. Torque the tensioning bolt to 24 to 30 ft-lb (32.5 to 40 N-m) to tighten the track (Figure 48).
5. Ensure that the track deflects less than 1/4 to 3/8 inch (0.6 to 1 cm) when 45 lb (20.6 kg) of force is applied to the track span. Adjust the torque on the tensioning bolt as needed.
6. Tighten the jam nut.

Replacing the Tracks

When the tracks are badly worn, replace them.

1. Lower the grinder.
2. Stop the engine, remove the key, and wait for all moving parts to stop before leaving the operating position.
3. Lift/support the side of the unit to be worked on so that the track is 3 to 4 inches (7.6 to 10 cm) off of the ground.
4. Back out the tensioning bolt and jam nut (Figure 48).
5. Push the tensioning wheel rearward as far as it will go (Figure 49).

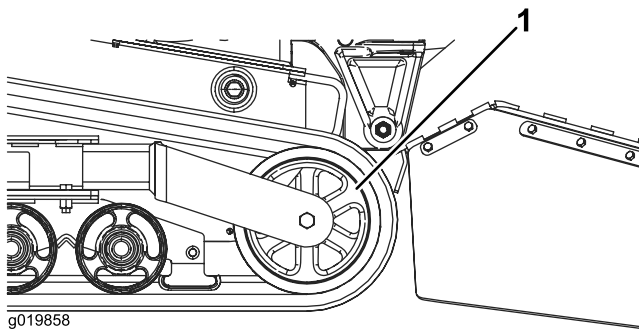

Figure 49

1. Tensioning wheel

6. Begin removing the track at the top of the tensioning wheel, peeling it off of the wheel while rotating the track forwards.
7. When the track is off of the tensioning wheel, remove it from the machine (Figure 49).
8. Beginning at the drive sprocket, coil the new track around the sprocket, ensuring that the lugs on the inside of the track fit between the spacers on the sprocket (Figure 46).
9. Push the track under and between the rear and center road wheels (Figure 46).
10. Starting at the bottom of the tensioning wheel, install the track around the wheel by rotating the track rearward while pushing the lugs into the wheel.
11. Install the tensioning bolt and jam nut.
12. Torque the tensioning bolt to 24 to 30 ft-lb (32.5 to 40 N-m) to tighten the track.
13. Ensure that the track deflects less than 1/4 to 3/8 inch (0.6 to 1 cm) when 45 lb (20.6 kg) of force is applied to the track span. Adjust the torque on the tensioning bolt as needed.
14. Tighten the jam nut.
15. Lower the machine to the ground.
16. Repeat steps 3 through 15 to replace the other track.

Checking and Greasing the Road Wheels

Service Interval: Every 250 hours

1. Remove the tracks; refer to [Replacing the Tracks \(page 31\)](#).
2. Remove the 4 bolts securing each lower track guide which contains the road wheels, and remove them (Figure 50).

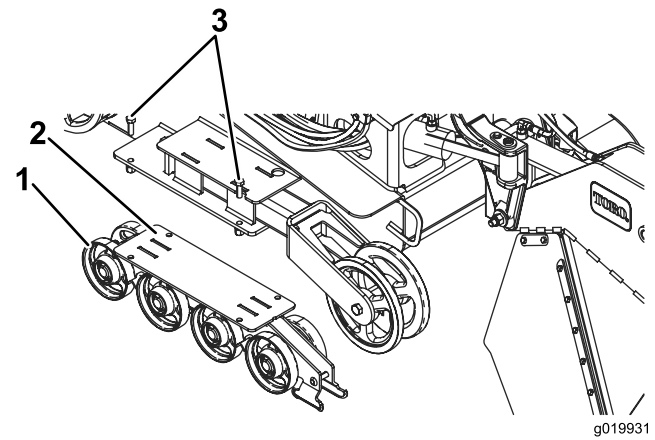

Figure 50

1. Road wheels
2. Lower track guide
3. Track guide bolts (only two shown)

3. Remove the snap ring and cap from a road wheel (Figure 51).

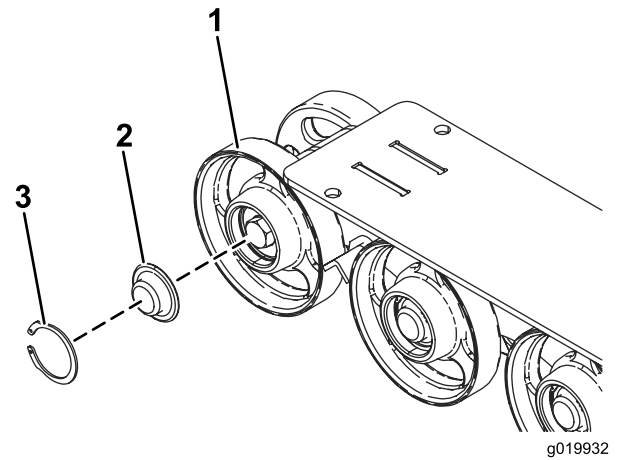

Figure 51

1. Road wheel
2. Road wheel cap
3. Snap ring

4. Check the grease under the cap and around the gasket (Figure 51). If it is dirty, gritty, or depleted, clean out all of the grease, replace the gasket, and add new grease.
5. Ensure that the road wheel turns smoothly on the bearing. If it is frozen, contact your Authorized Service Dealer to replace the road wheel.
6. Place the greased road wheel cap over the bolt head (Figure 51).
7. Secure the road wheel cap with the snap ring (Figure 51).
8. Repeat steps 3 through 7 for all road wheels.
9. Install each track guide to the traction unit frame using the fasteners you removed previously. Torque the bolts to 67 to 83 ft-lb (91 to 112 N-m).

10. Install the tracks; refer to [Replacing the Tracks \(page 31\)](#).

Cooling System Maintenance

Cleaning the Engine Screen

Service Interval: Before each use or daily

Before each use remove any build-up of grass, dirt or other debris from the engine screen. This will help ensure adequate cooling and correct engine speed and will reduce the possibility of overheating and mechanical damage to the engine.

Belt Maintenance

Replacing the Pump Drive Belt

If the pump drive belt begins to squeal or is cracked, worn, or frayed, replace it. Contact your Authorized Service Dealer for a replacement belt.

1. Raise the grinder and secure it with the grinder lock.
2. Stop the engine, remove the key, and wait for all moving parts to stop before leaving the operating position.
3. Raise the back of the machine and support it on jack stands.
4. Remove the bottom shield; refer to [Removing the Bottom Shield \(page 21\)](#).
5. Loosen the set screw on the pump drive coupler ([Figure 52](#)).

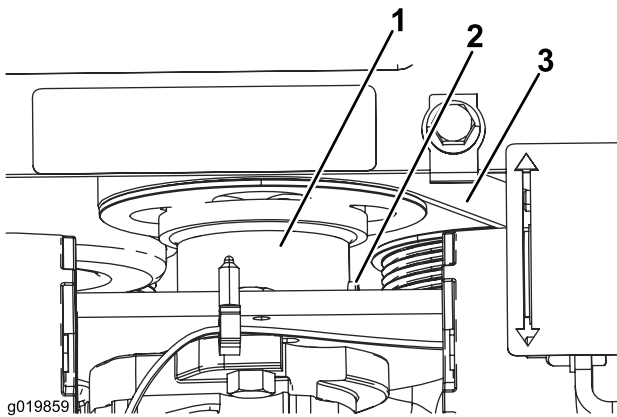

Figure 52

1. Pump drive coupler
2. Set screw
3. Belt

6. Drop the coupler down away from the pulley ([Figure 52](#)).
7. Using a spring puller (contact your Authorized Service Dealer) or stiff metal hook, pull the end of the idler pulley spring off of the spring bolt to release tension on the belt.
8. Remove the belt.
9. Route a new belt around the pulleys.
10. Install the idler pulley spring on the bolt.
11. Push the coupler up to engage the pulley.
12. Apply blue thread lock to the coupler set screw threads and torque it to 10 to 12.6 N-m (90 to 110 in-lb).
13. Install the bottom shield.

Controls System Maintenance

The factory adjusts the controls before shipping the machine. However, after many hours of use, you may need to adjust the traction control alignment, the neutral position of the traction control, and the tracking of the traction control in the full forward position.

Important: To adjust the controls properly, complete each procedure in the order listed.

Adjusting the Traction Control Alignment

If the traction control bar does not rest flush and square with the reference bar when in the full backward position, immediately complete the following procedure:

1. Park the machine on a flat surface and lower the grinder.
2. Stop the engine and remove the key.
3. Pull straight back on the traction control so the front of the control contacts the reference bar ([Figure 53](#)).

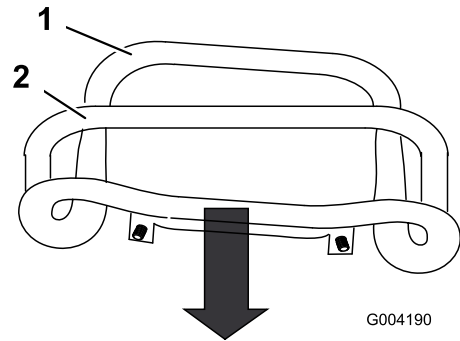

Figure 53

1. Front of the control, out of alignment
2. Reference bar

4. If the front of the traction control does not rest square and flush with the reference bar, loosen the flange nut and bolt in the stem of the traction control ([Figure 54](#)).

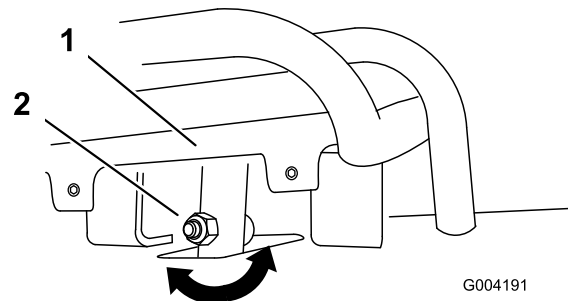

Figure 54

1. Traction control
2. Stem, bolt and nut

5. Adjust the traction control so that it rests flush against the reference bar when it is pulled straight back (Figure 54 and Figure 55).

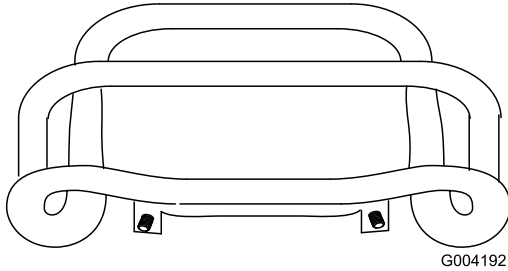

Figure 55

6. Tighten the flange nut and bolt in the traction control stem.
7. Start the engine.
8. Drive the machine in reverse with the traction control tight to the reference bar. If the machine does not back up straight, complete the following procedure:
 - A. Stop the engine
 - B. Lift/support the machine so that both tracks are off of the ground and are free to run.
 - C. Loosen the flange nut and bolt in the stem of the traction control (Figure 54).
 - D. Loosen the jam nuts on the traction rods, under the control panel (Figure 56).

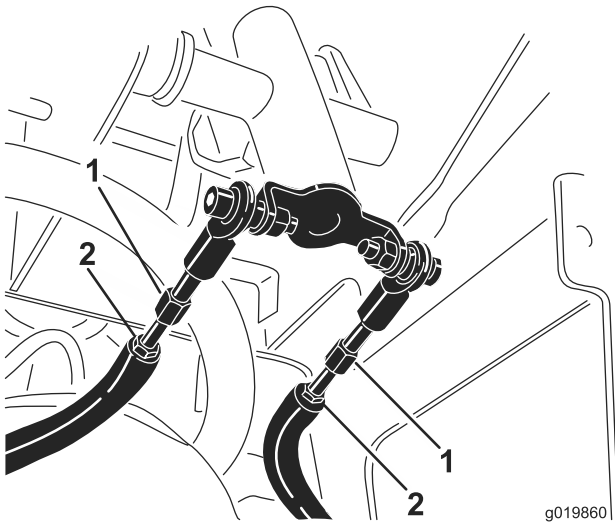

Figure 56

1. Traction rod
2. Jam nut

- E. Start the machine and set the throttle to about 1/3 open position.

⚠ WARNING

When the machine is running, you could be caught and injured in moving parts or burned on hot surfaces.

Stay away from pinch points, moving parts, and hot surfaces when adjusting the running machine.

- F. Have a helper hold the traction control tight to the reference bar in reverse.
- G. Adjust the length of the traction rods until both tracks are running at the same speed.

Note: You can also adjust the maximum reverse speed of the tracks at this time.
- H. Tighten the jam nuts.
 - I. Adjust the traction control so that it rests flush against the reference bar when it is pulled straight back (Figure 54 and Figure 55).
 - J. Tighten the flange nut and bolt in the traction control stem.
 - K. Stop the engine and lower the machine to the ground.
 - L. Drive the machine in full reverse, checking to see if the unit tracks straight. If it does not, note the direction the machine veers. Repeat the adjustment previously described so that it tracks straight in reverse.

Adjusting the Traction Control Neutral Position

If the machine creeps forward or backward when the traction control is in neutral and the unit is warm, the return-to-neutral mechanism on the pumps may need to be adjusted; contact your Authorized Service Dealer for repairs.

Adjusting the Tracking of the Traction Control, Full Forward Position

If the machine does not drive straight when you hold the traction control forward against the reference bar, complete the following procedure:

1. Drive the machine with the traction control against the reference bar, noting which direction the machine veers.
2. Release the traction control.
3. If the machine veers to the **left**, loosen the **right** jam nut and adjust the tracking set screw on the front of the traction control (Figure 57).

- If the machine veers to the **right**, loosen the **left** jam nut and adjust the tracking set screw on the front of the traction control (Figure 57).

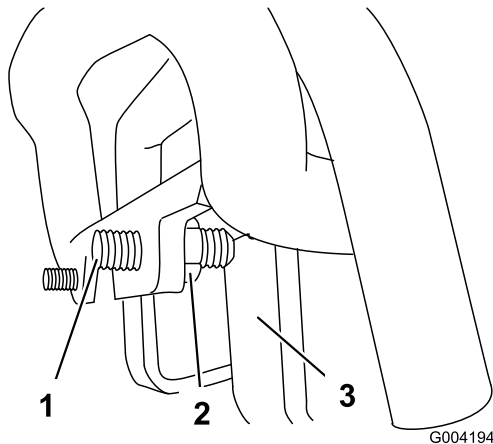

Figure 57

- Set screw
- Jam nut
- Stop

- Repeat steps 1 through 4 until the machine drives straight in the full forward position.

Important: Ensure the tracking set screws touch the stops in the full forward position to avoid over stroking the hydraulic pumps.

Hydraulic System Maintenance

Checking the Hydraulic-fluid Level

Service Interval: Every 25 hours

Hydraulic System Capacity: 38 L (10 US gallons)

Use **Toro Premium All Season Hydraulic Oil**.

The reservoir is filled at the factory with approximately 38 L (10 US gallons) of high-quality hydraulic fluid. Check the level of the hydraulic fluid before the engine is first started and daily thereafter. The recommended replacement fluid is as follows:

Toro Premium All Season Hydraulic Fluid (Available in 19 L (5 US gallon) pails or 208 L (55 gallon) drums. See the parts catalog or Toro distributor for part numbers)

Alternative fluids: If the Toro fluid is not available, other **conventional, petroleum-based** fluids may be used, provided they meet all of the following material properties and industry specifications. Check with your oil supplier to see whether the oil meets these specifications. Note: Toro will not assume responsibility for damage caused by improper substitutions, so use only products from reputable manufacturers who will stand behind their recommendation.

High Viscosity Index/Low Pour Point Anti-wear Hydraulic Fluid, ISO VG 46

Material Properties:

Viscosity, ASTM D445 cSt @ 40°C (104°F) 44 to 48
cSt @ 100°C (212°F) 7.9 to 9.1

Viscosity Index ASTM 140 or higher
D2270

Pour Point, ASTM D97 -37°C to -45°C (-34°F to -49°F)

FZG, Fail stage 11 or better

Water content (new fluid): 500 ppm (maximum)

Industry Specifications:

Vickers I-286-S, Vickers M-2950-S, Denison HF-0, Vickers 35 VQ 25 (Eaton ATS373-C)

The proper hydraulic fluids must be specified for mobile machinery (as opposed to industrial plant usage), multi-weight type, with ZnDTP or ZDDP anti-wear additive package (not an ashless-type fluid).

Important: Many hydraulic fluids are almost colorless, making it difficult to spot leaks. A red dye additive for the hydraulic system oil is available in 20 ml (2/3 fl oz) bottles. One bottle is sufficient for 15 to 22 L (4 to 6 US gallons) of hydraulic oil. Order part 44-2500 from your authorized Toro distributor.

1. Park the machine on a level surface and lower the grinder.
2. Stop the engine, remove the key, and allow the engine to cool.
3. Look into the glass bubble on the right side of the machine. If you cannot see hydraulic fluid in the bubble, continue this procedure to add fluid.

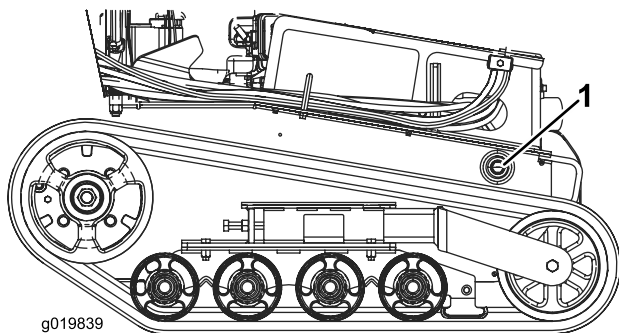

Figure 58

1. Hydraulic fluid check bubble

4. Remove the cover plate; refer to [Removing the Front Cover \(page 20\)](#).
5. Clean the area around the filler neck of the hydraulic tank and remove the cap and filter from the filler neck using a socket ([Figure 59](#)).

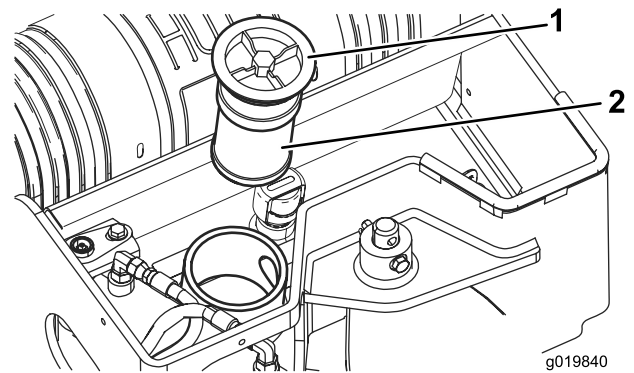

Figure 59

1. Filler neck cap
2. Hydraulic fluid filter

6. If the level is low, add fluid until it is visible in the glass bubble.
7. Install the cap and filter on the filler neck and torque bolt on top to 21 to 25 N-m (200 to 240 inch-lb).
8. Install the cover plate; refer to [Installing the Front Cover \(page 21\)](#).

Replacing the Hydraulic Filter

Service Interval: Every 200 hours

1. Position machine on a level surface.
2. Lower the grinder.
3. Stop the engine, remove the key, and wait for all moving parts to stop before leaving the operating position.
4. Remove the top cover.
5. Remove and discard the old filter ([Figure 60](#)).

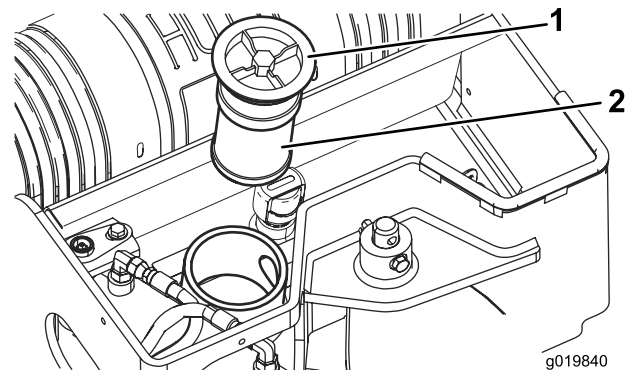

Figure 60

1. Filler cap
2. Hydraulic filter

6. Install the replacement hydraulic filter and filler cap ([Figure 60](#)) and torque bolt on top to 21 to 25 N-m (200 to 240 inch-lb).
7. Clean up any spilled fluid.
8. Install the top cover.

Changing the Hydraulic Fluid

Service Interval: Every 400 hours/Yearly (whichever comes first)

1. Position the machine on a level surface.
2. Lower the grinder.
3. Stop the engine, remove the key, and wait for all moving parts to stop before leaving the operating position.
4. Allow the machine to cool completely.
5. Remove the top cover.
6. Remove the hydraulic tank filler cap and filter (Figure 60).
7. Place a drain pan capable of holding 38 L (10 US gallons) under the hydraulic tank.
8. Remove the hydraulic tank drain plug and allow the fluid to drain into the pan (Figure 61).

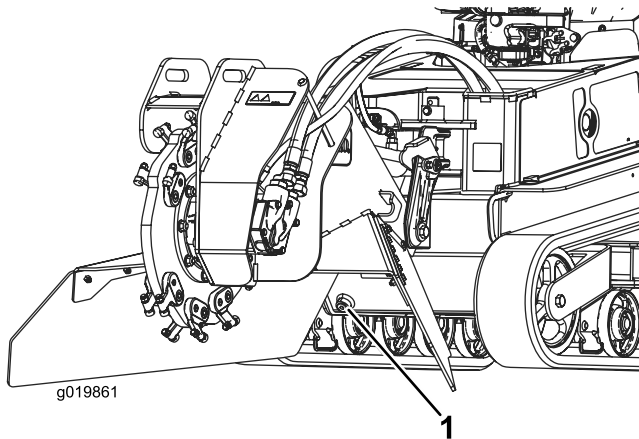

Figure 61

1. Hydraulic tank drain plug

9. When finished, install and tighten the drain plug.

Note: Dispose of the used oil at a certified recycling center.

10. Fill the hydraulic tank with approximately 38 L (10 US gallons) of Toro Premium All Season Hydraulic Oil; refer to [Checking the Hydraulic-fluid Level \(page 36\)](#).
11. Install the hydraulic filter and filler cap (Figure 60) and torque bolt on top to 21 to 25 N-m (200 to 240 inch-lb).
12. Start the engine and let it run for a few minutes.
13. Stop the engine.
14. Check the hydraulic fluid level and top it off if necessary; refer to [Checking the Hydraulic-fluid Level \(page 36\)](#).
15. Clean up any spilled fluid.
16. Install the top cover.

Checking the Hydraulic Lines

Service Interval: Every 100 hours—Check the hydraulic lines for leaks, loose fittings, kinked lines, loose mounting supports, wear, weather, and chemical deterioration and repair if necessary.

Every 1,500 hours/Every 2 years (whichever comes first)—Replace all moving hydraulic hoses.

⚠ WARNING

Hydraulic fluid escaping under pressure can penetrate skin and cause injury. Fluid injected into the skin must be surgically removed within a few hours by a doctor familiar with this form of injury or gangrene may result.

- Keep your body and hands away from pin hole leaks or nozzles that eject high pressure hydraulic fluid.
- Use cardboard or paper to find hydraulic leaks, never use your hands.

Grinder Maintenance

Replacing the Teeth

Service Interval: Before each use or daily—Check the condition of the teeth and rotate or replace any that are worn or damaged.

Due to the high amount of wear placed on the teeth, you will need to rotate and replace them periodically.

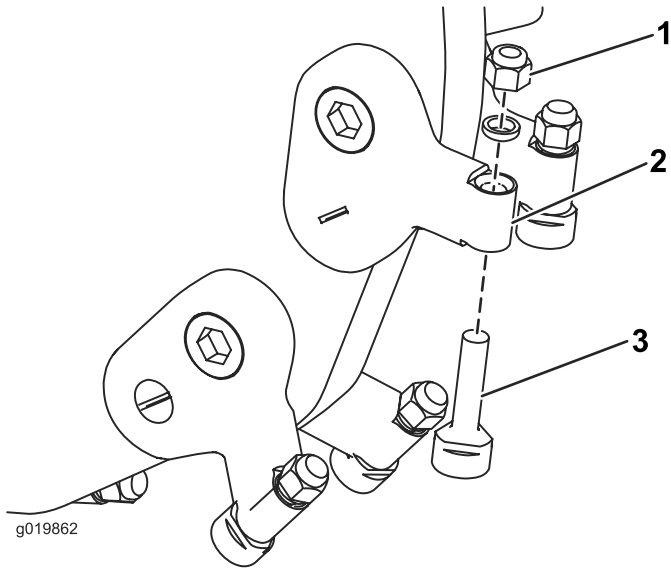

Figure 62

- | | |
|-----------------|----------|
| 1. Nut | 3. Tooth |
| 2. Tooth holder | |

Each tooth is indexed with three positions so you can rotate it twice, exposing a new sharp edge before replacing the tooth. To rotate a tooth, loosen the nut securing the tooth (Figure 62). Push the tooth forward and rotate it one third of a turn, bringing an unused edge to the outside. Torque the nut securing the tooth to 37 to 45 N-m (27 to 33 ft-lb).

To replace a tooth, remove the nut securing the tooth to remove it, then install a new tooth and nut in the same position (Figure 62). Torque the nut securing the tooth to 37 to 45 N-m (27 to 33 ft-lb).

Cleaning

Removing Debris from the Machine

Important: Operating the engine with blocked screens, dirty or plugged cooling fins, and/or cooling shrouds removed, will result in engine damage from overheating.

1. Lower the grinder.
2. Stop the engine, remove the key, and wait for all moving parts to stop before leaving the operating position.
3. Wipe away debris from the air cleaner.
4. Clean debris from the oil cooler.

Storage

1. Lower the grinder.
2. Stop the engine, remove the key, and wait for all moving parts to stop before leaving the operating position.
3. Remove dirt and grime from the external parts of the entire machine, especially the engine. Clean dirt and chaff from the outside of the engine cylinder-head fins and the blower housing.

Important: You can wash the machine with mild detergent and water. Do not pressure wash the machine. Avoid excessive use of water, especially near the control panel, engine, hydraulic pumps, and motors.

4. Service the air cleaner; refer to [Servicing the Air Cleaner \(page 23\)](#).
5. Grease the machine; refer to [Greasing the Machine \(page 22\)](#).
6. Change the engine oil; refer to [Changing the Engine Oil \(page 24\)](#).
7. For storage over 30 days, prepare the machine as follows:
 - A. Add a petroleum-based stabilizer/conditioner to the fuel in the tank. Follow the mixing instructions from the stabilizer manufacturer. **Do not use an alcohol-based stabilizer (ethanol or methanol).**

Note: Fuel stabilizer/conditioner is most effective when mixed with fresh gasoline and used at all times.
 - B. Run the engine to distribute conditioned fuel through the fuel system (5 minutes).
 - C. Stop the engine, allow it to cool and drain the fuel tank using a pump type syphon.
 - D. Start the engine and run it until it stops.
 - E. Start and run the engine until it will not start again.
 - F. Dispose of fuel properly. Recycle it as per local codes.

Important: Do not store stabilizer/conditioned gasoline over 90 days.

8. Remove the spark plugs and pour 2 tablespoons of engine oil into each spark-plug hole.
9. Place a rag over the spark plug holes to catch any oil spray, then use the starter to crank the engine and distribute the oil inside the cylinder.
10. Install the spark plugs, but do not install the wires on them.
11. Charge the battery; refer to [Charging the Battery \(page 30\)](#).

12. Check and adjust the track tension; refer to [Checking and Adjusting the Track Tension \(page 31\)](#).
13. Check and tighten all bolts, nuts, and screws. Repair or replace any part that is damaged.
14. Paint all scratched or bare metal surfaces. Paint is available from your Authorized Service Dealer.
15. Store the machine in a clean, dry garage or storage area. Remove the key from the ignition switch and keep it in a memorable place.
16. Cover the machine to protect it and keep it clean.

Troubleshooting

Problem	Possible Cause	Corrective Action
The starter does not crank.	<ol style="list-style-type: none"> 1. The battery is discharged. 2. The electrical connections are corroded or loose. 3. The relay or switch is damaged. 	<ol style="list-style-type: none"> 1. Charge the battery or replace it. 2. Check the electrical connections for good contact. 3. Contact your Authorized Service Dealer.
The engine will not start, starts hard, or fails to keep running.	<ol style="list-style-type: none"> 1. The fuel tank is empty. 2. The fuel shutoff valve is closed. 3. The controls are not in neutral. 4. The air cleaner is dirty. 5. A spark plug wire is loose or disconnected. 6. A spark plug is pitted, fouled, or the gap is incorrect. 7. Dirt, water, or stale fuel is in fuel system. 	<ol style="list-style-type: none"> 1. Fill the fuel tank with gasoline. 2. Open the fuel shutoff valve. 3. Move the controls to neutral. 4. Clean or replace the air cleaner elements. 5. Install the wire on the spark plug. 6. Install a new, correctly gapped spark plug. 7. Contact your Authorized Service Dealer.
Engine loses power.	<ol style="list-style-type: none"> 1. The engine load is excessive. 2. The air cleaner is dirty. 3. The oil level in crankcase is low. 4. The cooling fins and air passages under the engine blower housing are plugged. 5. A spark plug is pitted, fouled, or the gap is incorrect. 6. Dirt, water, or stale fuel is in fuel system. 	<ol style="list-style-type: none"> 1. Reduce ground speed. 2. Clean or replace the air cleaner elements. 3. Check and add oil to the crankcase. 4. Remove any obstructions from the cooling fins and air passages. 5. Install a new, correctly gapped spark plug. 6. Contact your Authorized Service Dealer.
The engine overheats.	<ol style="list-style-type: none"> 1. The engine load is excessive. 2. The oil level in crankcase is low. 3. The engine cooling system is dirty. 	<ol style="list-style-type: none"> 1. Reduce ground speed. 2. Check and add oil to the crankcase. 3. Clean the engine and engine oil cooler.
Abnormal vibration.	<ol style="list-style-type: none"> 1. The engine mounting bolts are loose. 	<ol style="list-style-type: none"> 1. Tighten the engine mounting bolts.
The machine does not drive.	<ol style="list-style-type: none"> 1. The hydraulic fluid level is low. 2. The tow valves are open. 3. The hydraulic system is damaged. 	<ol style="list-style-type: none"> 1. Check and add hydraulic fluid. 2. Close the tow valves. 3. Contact your Authorized Service Dealer.
The grinder does not turn	<ol style="list-style-type: none"> 1. A chunk of wood or a rock is caught in the grinder. 2. The grinder drive system is damaged. 3. The hydraulic system is obstructed, contaminated, or damaged. 	<ol style="list-style-type: none"> 1. Stop the engine and remove the obstruction with a stick. 2. Contact your Authorized Service Dealer. 3. Contact your Authorized Service Dealer.
The grinder does not cut fast enough	<ol style="list-style-type: none"> 1. The teeth are worn. 2. The hydraulic system is overheated. 3. The hydraulic system is obstructed, contaminated, or damaged. 	<ol style="list-style-type: none"> 1. Rotate or replace the teeth. 2. Stop the engine and allow the system to cool. 3. Contact your Authorized Service Dealer.
The Grinder head does not lower or raise.	<ol style="list-style-type: none"> 1. The lift/lower control valve is closed. 	<ol style="list-style-type: none"> 1. Turn the control dial counter clockwise to open it.
The hydraulic oil overflows or is very hot.	<ol style="list-style-type: none"> 1. The cooling fan is not functioning. 	<ol style="list-style-type: none"> 1. Check the fuse and replace it if necessary.

Schematics

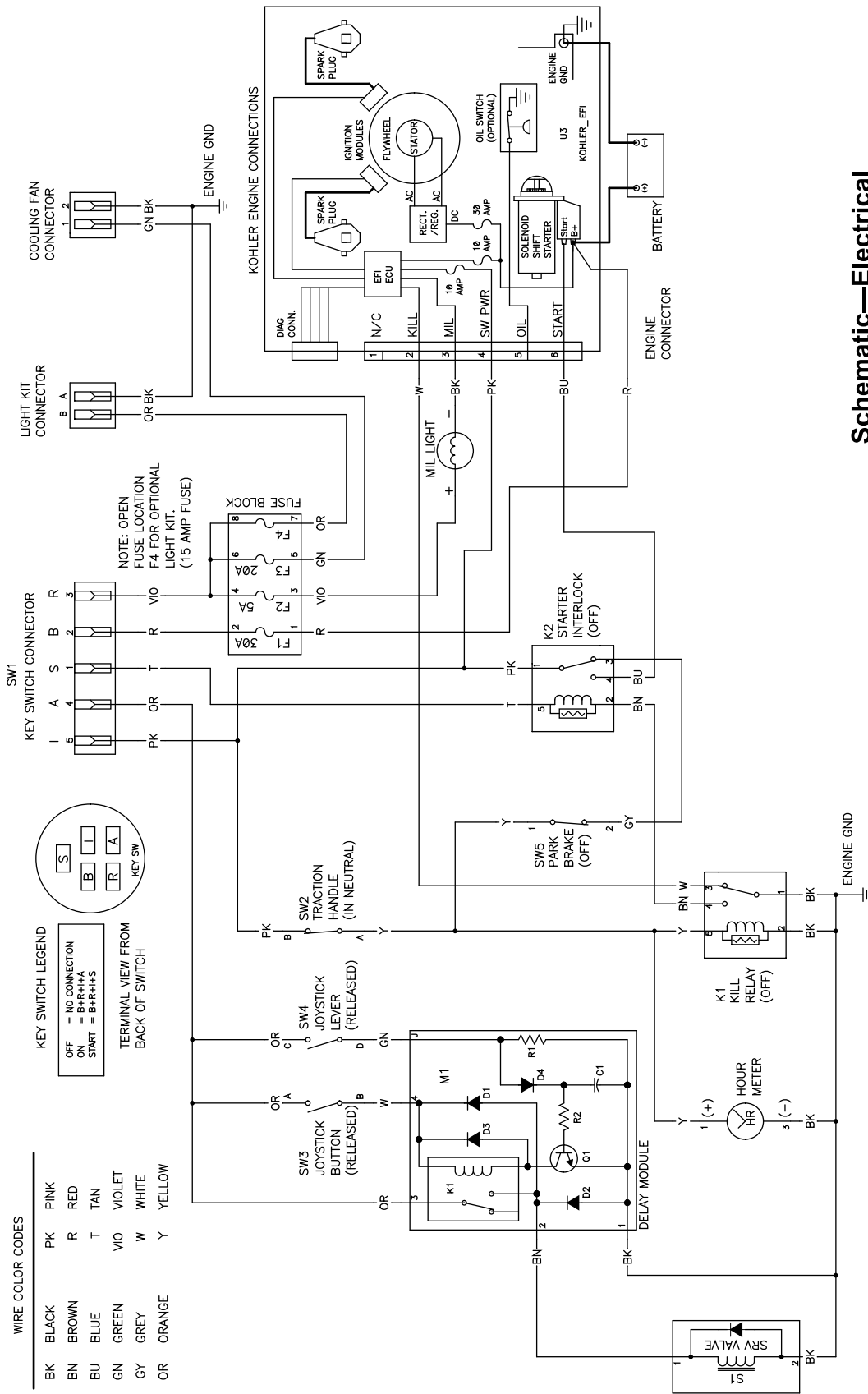

Schematic—Electrical
 Model 23214
 Sheet 1 of 1 | DWG 130-7573 | Rev A

Electrical Schematic (Rev. A)

G025620

COMPONENT	DISPLACEMENT AND PRESSURE			FLOWRATE*		
	CU IN/REV	CU CM/REV	PSI	BARS	GPM	LPM
P1	1.29	21.1	3625	250	20.1	76.1
P2	.12	2.0	3770	260	1.9	7.0
P3, P4	.97	15.9	3000	207	15.1	57.2
M1	3.0	49.2	-----	-----	-----	-----
M2, M3	24.7	405	-----	-----	-----	-----
RV1	-----	3000	207	-----	-----	-----
RV2	-----	500	35	-----	-----	-----
RV3	-----	2030	140	-----	-----	-----
RV4	-----	1000	69	-----	-----	-----
RV5	-----	2000	138	-----	-----	-----
CBV1, CBV2	-----	-----	1000	69	-----	-----

* FLOWRATE IS THEORETICAL. IT IS CALCULATED USING ENGINE SPEED OF 3600 RPM. IT DOES NOT ACCOUNT FOR COMPONENT EFFICIENCIES.

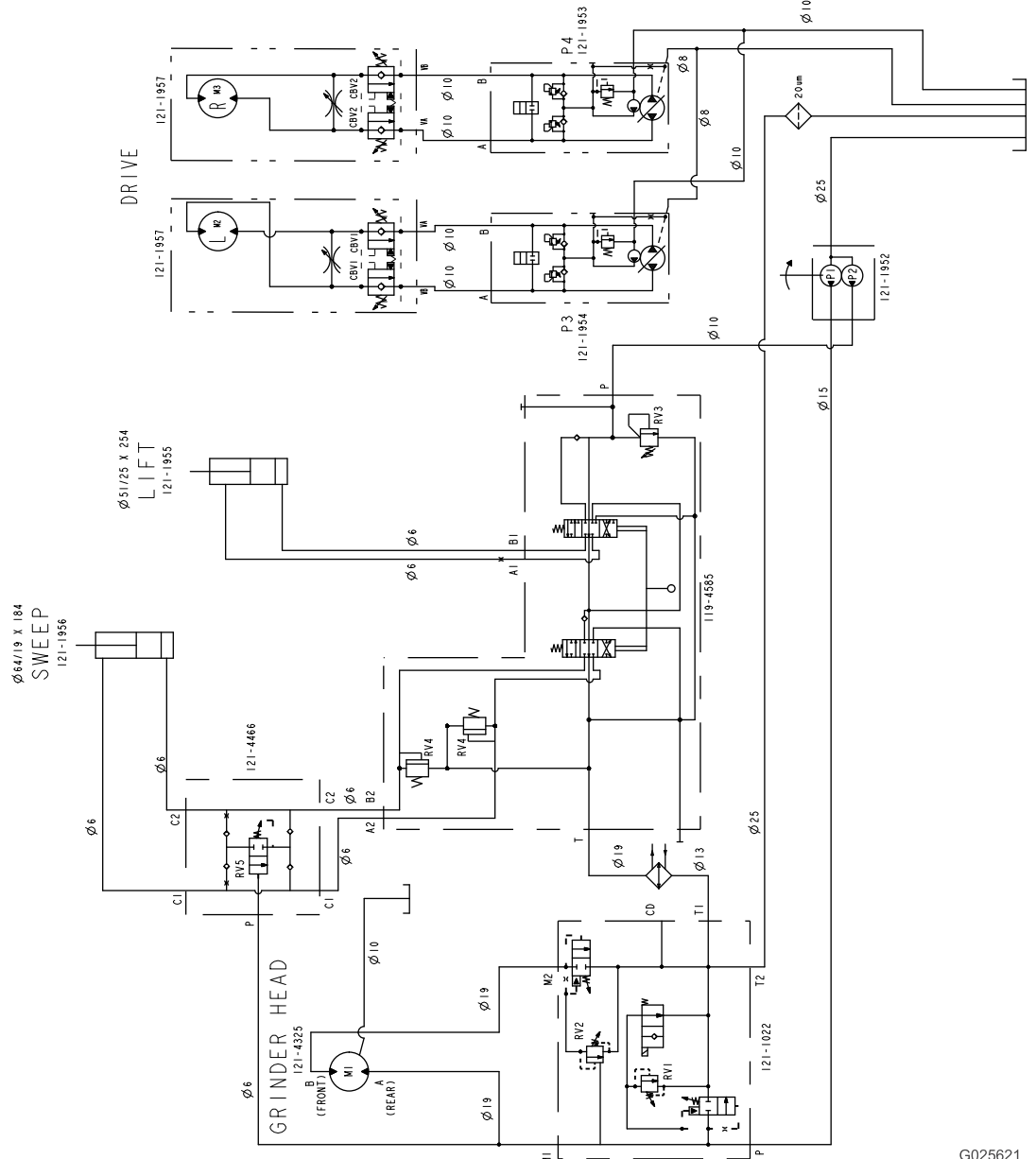

Hydraulic Schematic (Rev. A)

Schematic—Hydraulic
 Model 23214
 Sheet 1 of 1 | DWG 130-7570 | Rev A

G025621

Notes:

Notes:

Notes:

International Distributor List

Distributor:	Country:	Phone Number:	Distributor:	Country:	Phone Number:
Agrolanc Kft	Hungary	36 27 539 640	Maquiver S.A.	Colombia	57 1 236 4079
Balama Prima Engineering Equip.	Hong Kong	852 2155 2163	Maruyama Mfg. Co. Inc.	Japan	81 3 3252 2285
B-Ray Corporation	Korea	82 32 551 2076	Mountfield a.s.	Czech Republic	420 255 704 220
Casco Sales Company	Puerto Rico	787 788 8383	Mountfield a.s.	Slovakia	420 255 704 220
Ceres S.A.	Costa Rica	506 239 1138	Munditol S.A.	Argentina	54 11 4 821 9999
CSSC Turf Equipment (pvt) Ltd.	Sri Lanka	94 11 2746100	Norma Garden	Russia	7 495 411 61 20
Cyril Johnston & Co.	Northern Ireland	44 2890 813 121	Oslinger Turf Equipment SA	Ecuador	593 4 239 6970
Cyril Johnston & Co.	Republic of Ireland	44 2890 813 121	Oy Hako Ground and Garden Ab	Finland	358 987 00733
Equivar	Mexico	52 55 539 95444	Parkland Products Ltd.	New Zealand	64 3 34 93760
Femco S.A.	Guatemala	502 442 3277	Perfetto	Poland	48 61 8 208 416
ForGarder OU	Estonia	372 384 6060	Pratoverde SRL.	Italy	39 049 9128 128
G.Y.K. Company Ltd.	Japan	81 726 325 861	Prochaska & Cie	Austria	43 1 278 5100
Geomechaniki of Athens	Greece	30 10 935 0054	RT Cohen 2004 Ltd.	Israel	972 986 17979
Golf international Turizm	Turkey	90 216 336 5993	Riversa	Spain	34 9 52 83 7500
Guandong Golden Star	China	86 20 876 51338	Lely Turfcare	Denmark	45 66 109 200
Hako Ground and Garden	Sweden	46 35 10 0000	Solvret S.A.S.	France	33 1 30 81 77 00
Hako Ground and Garden	Norway	47 22 90 7760	Spypros Stavrinides Limited	Cyprus	357 22 434131
Hayter Limited (U.K.)	United Kingdom	44 1279 723 444	Surge Systems India Limited	India	91 1 292299901
Hydroturf Int. Co Dubai	United Arab Emirates	97 14 347 9479	T-Markt Logistics Ltd.	Hungary	36 26 525 500
Hydroturf Egypt LLC	Egypt	202 519 4308	Toro Australia	Australia	61 3 9580 7355
Irrimac	Portugal	351 21 238 8260	Toro Europe NV	Belgium	32 14 562 960
Irrigation Products Int'l Pvt Ltd.	India	0091 44 2449 4387	Valtech	Morocco	212 5 3766 3636
Jean Heybroek b.v.	Netherlands	31 30 639 4611	Victus Emak	Poland	48 61 823 8369

European Privacy Notice

The Information Toro Collects

Toro Warranty Company (Toro) respects your privacy. In order to process your warranty claim and contact you in the event of a product recall, we ask you to share certain personal information with us, either directly or through your local Toro company or dealer.

The Toro warranty system is hosted on servers located within the United States where privacy law may not provide the same protection as applies in your country.

BY SHARING YOUR PERSONAL INFORMATION WITH US, YOU ARE CONSENTING TO THE PROCESSING OF YOUR PERSONAL INFORMATION AS DESCRIBED IN THIS PRIVACY NOTICE.

The Way Toro Uses Information

Toro may use your personal information to process warranty claims, to contact you in the event of a product recall and for any other purpose which we tell you about. Toro may share your information with Toro's affiliates, dealers or other business partners in connection with any of these activities. We will not sell your personal information to any other company. We reserve the right to disclose personal information in order to comply with applicable laws and with requests by the appropriate authorities, to operate our systems properly or for our own protection or that of other users.

Retention of your Personal Information

We will keep your personal information as long as we need it for the purposes for which it was originally collected or for other legitimate purposes (such as regulatory compliance), or as required by applicable law.

Toro's Commitment to Security of Your Personal Information

We take reasonable precautions in order to protect the security of your personal information. We also take steps to maintain the accuracy and current status of personal information.

Access and Correction of your Personal Information

If you would like to review or correct your personal information, please contact us by email at legal@toro.com.

Australian Consumer Law

Australian customers will find details relating to the Australian Consumer Law either inside the box or at your local Toro Dealer.



The Toro Warranty
A limited warranty (see warranty periods below)

SWS
Tree Care

Conditions and Products Covered

The Toro Company and its affiliate, Toro Warranty Company, pursuant to an agreement between them, jointly warrant your Toro Products listed below to be free from defects in materials or workmanship.

This warranty covers the cost of parts and labor, but you must pay transportation costs.

The following time periods apply from the date of purchase:

Products	Warranty Period
Tree Care	
Log Splitter	1 year
• Battery	90 days Parts and Labor
	1 year Parts Only
• Engine	2 years
Stump Grinder	1 year
• Engine	2 years
Brush Chipper	1 year
• Battery	90 days Parts and Labor
	1 year Parts Only
• Engine	3 years

Where a warrantable condition exists, we will repair the Product at no cost to you including diagnosis, labor, and parts.

Instructions for Obtaining Warranty Service

If you think that your Toro Product contains a defect in materials or workmanship, follow this procedure¹:

1. Contact any Authorized Servicing Outlet to arrange service at their dealership. To locate one convenient to you, access our website at www.Toro.com. Select "Where to Buy" and select "Contractor" under product type. You may also call our toll free number below.
2. Bring the product and your proof of purchase (sales receipt) to them.
3. If for any reason you are dissatisfied with the Service Outlet's analysis or with the assistance provided, contact us at:

SWS Customer Care Department
Toro Warranty Company
8111 Lyndale Avenue South
Bloomington, MN 55420-1196
Toll Free: 888-384-9940

¹Toro Authorized Rental Customers who have purchased products directly from Toro and have signed the Toro Rental Customer Agreement have the ability to perform their own warranty work. Please visit Toro's Rental Portal for electronic warranty claim filing procedures or call the toll free number above.

Owner Responsibilities

You must maintain your Toro Product by following the maintenance procedures described in the *Operator's Manual*. Such routine maintenance, whether performed by a dealer or by you, is at your expense. Parts scheduled for replacement as required maintenance ("Maintenance Parts"), are warranted for the period of time up to the scheduled replacement time for that part. Failure to perform required maintenance and adjustments can be grounds for disallowing a warranty claim.

Countries Other than the United States or Canada

Customers who have purchased Toro products outside the United States or Canada should contact their Toro Distributor (Dealer) to obtain guarantee policies for your country, province, or state. If for any reason you are dissatisfied with your Distributor's service or have difficulty obtaining guarantee information, contact the Toro importer. If all other remedies fail, you may contact us at Toro Warranty Company.

Australian Consumer Law: Australian customers will find details relating to the Australian Consumer Law either inside the box or at your local Toro Dealer.

Items and Conditions Not Covered

Not all product failures or malfunctions that occur during the warranty period are defects in materials or workmanship. This express warranty does not cover the following:

- Product failures which result from installation and use of add-on, modified, or unapproved accessories
- Failure to perform required maintenance and/or adjustments
- Repairs necessary due to failure to follow recommended fuel procedure (consult *Operator's Manual* for more details)
 - Removing contaminants from the fuel system is not covered
 - Use of old fuel (more than one month old) or fuel which contains more than 10% ethanol or more than 15% MTBE
 - Failure to drain the fuel system prior to any period of non-use over one month
- Product failures which result from operating the product in an abusive, negligent or reckless manner
- Parts subject to consumption through use unless found to be defective. Examples of parts which are consumed, include, belts, cutters, blades, teeth, spark plugs, tires, filters, etc.
- Failures caused by outside influence include, weather, storage, contamination, lubricants, additives, or chemicals, etc.
- Normal "wear and tear" items includes painted surfaces and scratched decals, etc.
- Any component covered by a separate manufacturer's warranty
- Pickup and delivery charges

General Conditions

Repair by an Authorized Servicing Outlet or Self-Service as an Authorized Rental Customer is your sole remedy under the warranty.

Neither The Toro Company nor Toro Warranty Company is liable for indirect, incidental or consequential damages in connection with the use of the Toro Products covered by this warranty, including any cost or expense of providing substitute equipment or service during reasonable periods of malfunction or non-use pending completion of repairs under this warranty. All implied warranties of merchantability and fitness for use are limited to the duration of this express warranty. Some states do not allow exclusions of incidental or consequential damages, or limitations on how long an implied warranty lasts, so the above exclusions and limitations may not apply to you.

This warranty gives you specific legal rights, and you may also have other rights which vary from state to state.

Except for the engine warranty coverage and the Emissions warranty referenced below, if applicable, there is no other express warranty. The Emissions Control System on your Product may be covered by a separate warranty meeting requirements established by the U.S. Environmental Protection Agency (EPA) or the California Air Resources Board (CARB). Refer to the California Emission Control Warranty Statement supplied with your Product or contained in the engine manufacturer's documentation for details.