

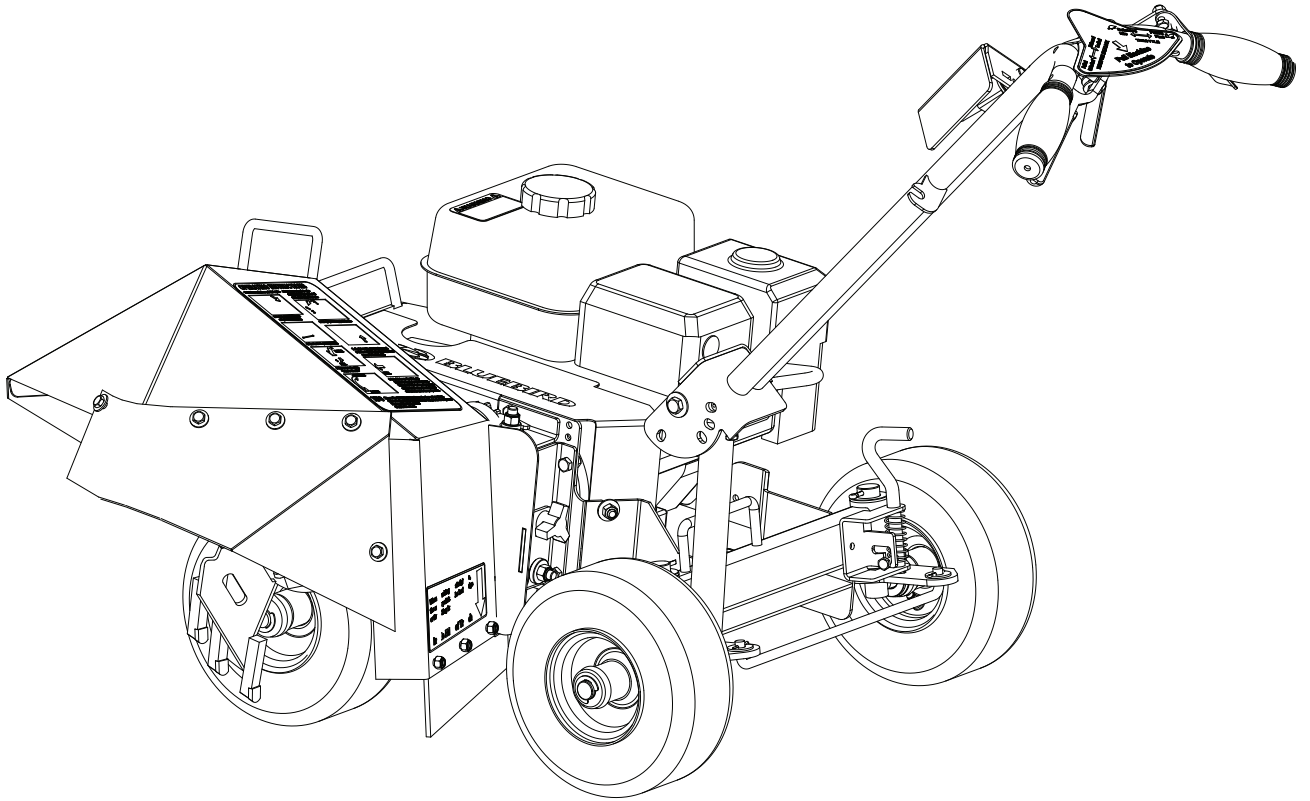

BLUEBIRD

Operator Manual



BB550A / 968999494

Please read the operator's manual carefully and make sure you understand the instructions before using the machine.

CONTENTS

INTRODUCTION	4	OPERATION	14
Use	4	General	14
Good Service	4	Bed Shaping	14
Serial Number	4	MAINTENANCE	15
SYMBOLS AND DECALS	5	Maintenance Schedule	15
Safety Decals and Machine Mounted Instructions	5	Drive Chain	16
SAFETY	6	Tightening	16
General Use	6	Checking Drive Chain And Sprockets	16
Preparations	8	Replacing Drive Chain	17
Operating	9	Cleaning	17
Movement/Transport	9	Service	17
Storage	9	Storage	18
Fuel System	10	LUBRICATION	19
Maintenance	10	Lubrication schedule	19
ASSEMBLY	11	TROUBLESHOOTING	20
CONTROLS	12	SERVICE JOURNAL	22
Steering/Locking Handle	12	Delivery Service	22
Handle Lock	12	After the first 20 hours	22
Throttle Lever	12		
Depth Control Setting Plate	12		
Transport/Engaged Lever	13		

INTRODUCTION

Congratulations

Thank you for purchasing a BlueBird lawn care product. Through your confidence in us, you have chosen an exceptionally high quality product.

This manual is a valuable document. It describes your new BlueBird machine. Read the manual carefully before attempting to use the machine. Following the instructions (use, service, maintenance, etc.) can considerably increase the lifespan of your machine and even increase its resale value. Please contact your dealer for more information.

If you sell your BlueBird machine, make sure to give the operator's manual to the new owner.

Use

The machine is used to lay edging material and to shape landscaping beds.

Insure your machine

Contact your insurance company to check on insurance coverage for your new machine. You should have all-inclusive insurance for liability, fire, damage and theft.

Good Service

Before the machine was delivered it underwent inspection and was adjusted by your dealer. When you need spare parts or support in service questions, warranty issues, etc., please consult the following professional:

This manual belongs to the machine with the serial number:	Engine

Serial Number

The machine's serial number can be found on the printed plate attached to the chassis of the machine. The plate includes the following information:

- The machine's type designation (MODEL).
- The machine's serial number (S/N).

Please state the type designation and serial number when ordering spare parts.

The engine's serial number is printed on the engine.

The engine type is specified on the crankcase under the air filter but also appears on the decal on the starter.

Please state engine serial number and type when ordering replacement engine parts.

SYMBOLS AND DECALS

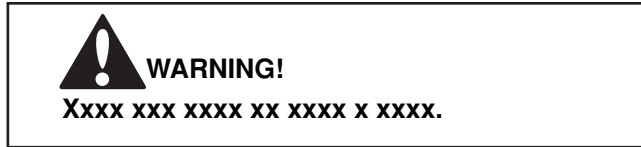

Used in this publication to notify the reader of a risk of **personal injury**, particularly if the reader **DOES NOT** follow the instructions given in the manual.



Used in this publication to notify the reader of a risk of **material damage**, particularly if the reader **DOES NOT** follow the instructions given in the manual. Used also when there is a potential for misuse or misassembly.

Safety Decals and Machine Mounted Instructions

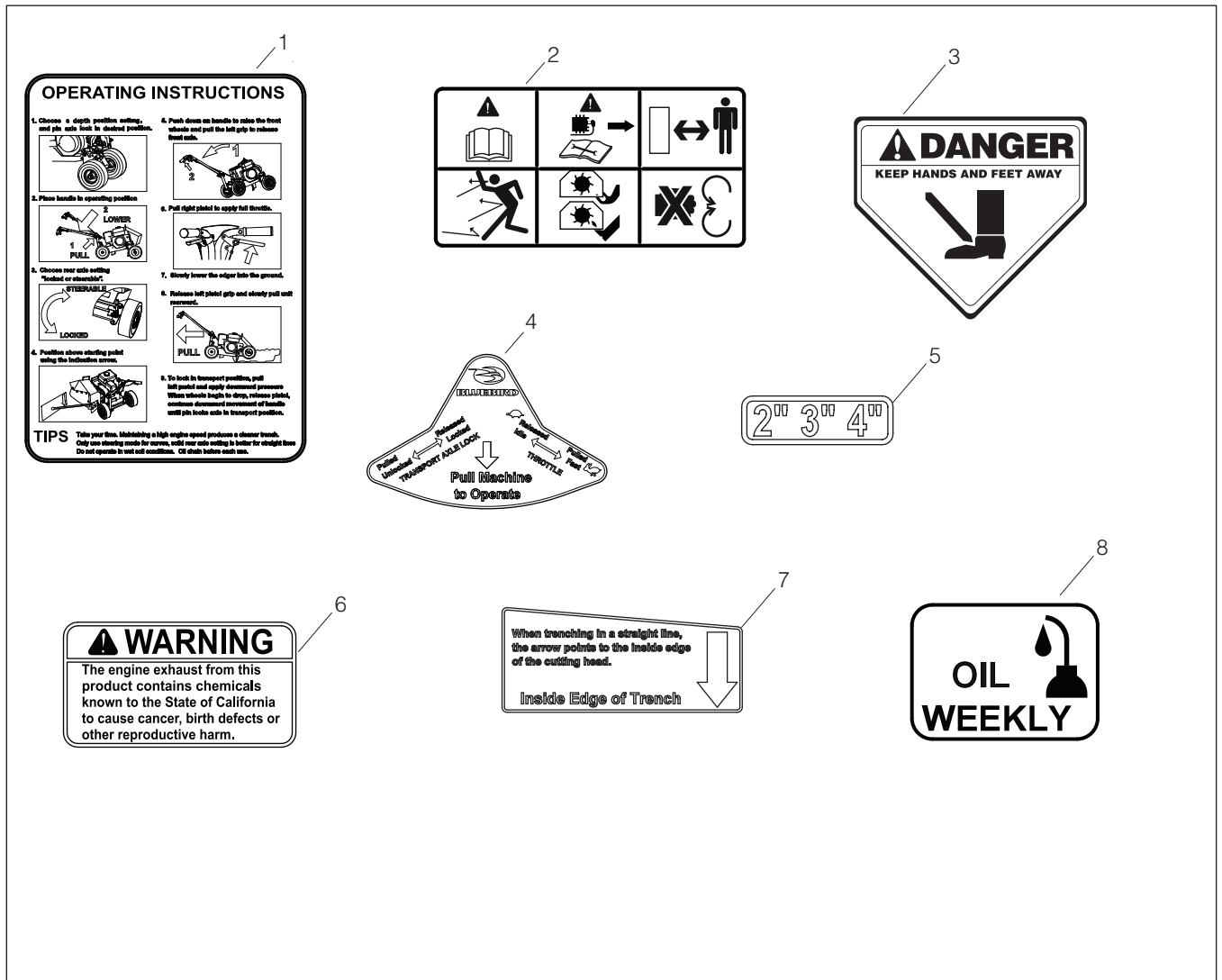

- | | |
|---------------------------|--------------------------------|
| 1. Operating instructions | 5. Depth decal |
| 2. Safety graphics | 6. Warning for carbon monoxide |
| 3. DANGER watch your feet | 7. Guideline decal |
| 4. Control operations | 8. Oiling decal |

SAFETY

General Use

The object of this manual is to help you use your BlueBird machine safely and to provide information about how to maintain the machine. Please read the manual carefully before attempting to use the machine.

If after reading the operator's manual you are still unsure about the safety risks associated with use of the machine, you should not use the machine. Please contact your dealer for more information.

These safety instructions only address the basics for safe use. It would be impossible in the safety instructions to describe all possible risk situations that could arise when using the machine. You can, however, prevent accidents by always using common sense.

To obtain extra copies of the operator's manual, please contact your dealer.

IMPORTANT INFORMATION

Do not use the machine until you have read the operator's manual carefully and understand the instructions given. All maintenance work or adjustments not described in this manual must be performed by an authorized BlueBird service workshop.

- Read this manual carefully and make sure you understand it before using the machine or performing any maintenance. If the user cannot read this manual, it is the responsibility of the machine owner to explain the contents to the user.
- Follow all safety instructions. Failure to do so may result in injury to yourself or others.
- Accident prevention regulations, other general safety regulations, occupational safety rules and traffic regulations must be followed without fail.
- All users shall be trained in use of the machine. The owner is responsible for training users.
- Engage an authorized BlueBird workshop for all service and repairs not described in this manual.



WARNING!

Under no circumstances may the original design of the machine be modified without written approval from the manufacturer. Such modifications not only affect the performance and durability of the machine but may even pose a safety risk for users and those in the vicinity. Unauthorized modifications to the design of the machine may absolve the manufacturer from liability for any resulting personal injury or property damage. Modifying the machine without written approval from the manufacturer may void the guarantee.



WARNING!

Engine exhaust, some of its constituents and certain vehicle components contain or emit chemicals considered by the State of California to cause cancer, birth defects or other reproductive harm. The engine emits carbon monoxide, which is a colorless, poisonous gas. Do not use the machine in enclosed spaces.

SAFETY

- BlueBird original spare parts are designed and specified to maintain high quality and correct fit for optimal durability and lifespan. From a safety point of view, you should only use BlueBird original spare parts.
- Check that all safety decals are in place. See the chapter ***Symbols and Decals***.
- Learn how to use the machine and its controls safely and learn to recognize the safety decals.
- Check that the machine is in serviceable condition prior to use; see ***Maintenance Schedule*** in the ***Maintenance*** chapter.
- Only use the machine in daylight or in other well-lit conditions. Keep the machine a safe distance from holes or other irregularities in the ground. Pay attention to other possible risks.
- Only allow the machine to be used by adults who are familiar with its use.
- Never allow persons not trained in the use of the machine to service it.
- Never allow children or persons not trained in the use of the machine to use it. Local laws may regulate the age of the user.
- People and animals can distract you causing you to lose control of the machine. For this reason, you should always concentrate and focus on the task at hand.
- Never leave the machine unsupervised with the engine running.
- Make sure that other people are nearby when you are using the machine so that you can call for help should an emergency arise.
- The machine is tested and approved only with the equipment originally provided or recommended by the manufacturer.



WARNING!

The engine can become very hot. To avoid being burned, you must turn off the engine and wait until all parts have cooled before touching the engine.



WARNING!

Overexposure to vibration may lead to circulatory or nerve damage, particularly in people who have impaired circulation. Contact your doctor if you experience symptoms that could have been caused by overexposure to vibration. Examples of common symptoms include numbness, pain, muscle weakness, change of skin color or an uncomfortable feeling of tingling. These symptoms appear most frequently in the fingers, hands or wrists.

SAFETY

Preparations

- Have first aid equipment at hand when using the machine.
- Check that nobody else is in the vicinity of the machine when you start the engine, engage the drive or run the machine.
- Keep animals and people a safe distance from the machine.
- Clear the area of objects such as stones, toys, steel wire, etc. that could become caught in moving machine parts and thrown out.
- Find and locate all fixed objects in the ground, such as sprinkler systems, poles, water valves, bases for washing lines, etc. Be certain to check for hidden electrical cables or similar in the surface of the lawn. Always run the machine around these objects. Never intentionally run the machine over foreign objects.
- Ensure that all guard plates and protective shields are in place and intact when using the machine. Ensure that all protective devices are in place when the machine is in use.
- Remove loose clothing or jewelry and secure long hair that can catch in moving machine parts.
- Wear protective shoes or boots. It is recommended that the footwear have anti-slip with steel toes. Never use the machine when barefoot.
- Wear approved ear-protection when running the machine. Ask your dealer about approved ear-protection.
- Observe all safety instructions; otherwise you may injure yourself or others around you.
- Make sure that the machine is in serviceable condition prior to use.
- Stop the engine and wait until all machine movement comes to a standstill before service, adjustment or cleaning.
- Do not run the engine in poorly ventilated spaces.
- Avoid slopes that are too steep to use the machine safely.



WARNING!

Always use approved protective clothing and approved protective equipment when using the machine. Protective clothing and protective equipment cannot eliminate the risk of accidents, but wearing proper clothing and the correct equipment will reduce the degree of injury should an accident occur. Ask your dealer about approved protective clothing and approved protective equipment recommended by BlueBird.

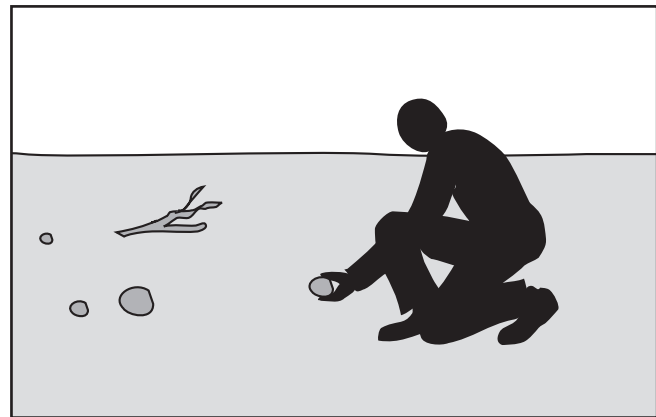

8011-198

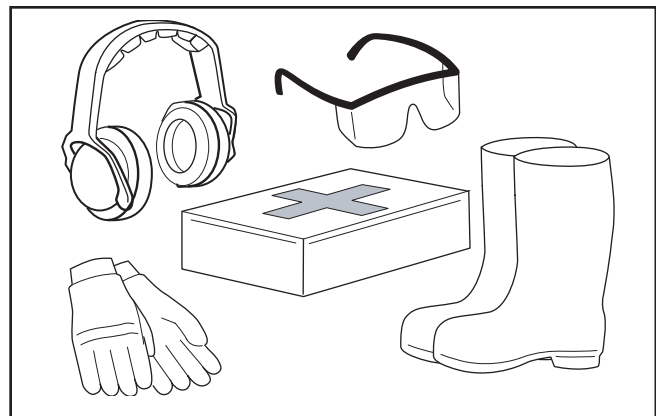

8011-670-a

SAFETY

Operating

- Do not use the machine if you are tired, if you have consumed alcohol, or if you are taking other drugs or medication that can affect your vision, judgment or co-ordination.
- Never use the machine indoors or in spaces lacking proper ventilation.
- Do not use the machine on any surface other than grass.
- Make sure you have a proper foothold when using the machine, particularly when backing. Walk, don't run. Never work on wet grass. Poor traction may cause you to slip.
- Keep your hands and feet away from moving parts.
- Keep your hands and feet away from the work tools.
- Slow down and be especially careful on slopes. Make sure to run the machine in the recommended direction on slopes. Be careful when working close to sudden changes in level.
- Smoking, open flames or sparks in the vicinity of the machine are strictly forbidden. Gasoline is extremely flammable and carelessness in handling can result in personal injury or fire.
- Stop and inspect the equipment if you run over or into anything. If necessary, make repairs before beginning again.
- Whatever happens, you should always park the machine on even ground, disengage the drive, turn off the engine and wait until all moving parts have stopped before leaving the operating position behind the machine.
- Be careful when trenching in hard ground. The tines may catch in the ground and propel the machine forward. If this occurs, let go of the handlebars and do not restrain the machine.
- Start the engine carefully and with feet well away from the tines.



Movement/Transport

- To turn and steer the machine, unlock the wheel and pull by the handle.
- Collapse the handle if the machine is so equipped.
- Turn off the engine and allow it to cool at least 2



WARNING!

Engine exhaust, some of its constituents and certain vehicle components contain or emit chemicals considered to cause cancer, birth defects or other reproductive harm. The engine emits carbon monoxide, which is a colorless, poisonous gas. Do not use the machine in enclosed spaces.

minutes before transport.

- Be careful and use safe lifting and moving techniques when loading/unloading the machine. It is recommended that two people lift the machine.
- Fasten the machine properly in place with approved fasteners, such as tension belts, chains or rope. Always check that you are in compliance with applicable traffic regulations before transporting the machine.

Storage

- Allow the engine to cool before storing the machine. Never store the machine near a open flame.
- Store the machine with the fuel valve closed.
- Store the machine and fuel in such a way that there is no risk that leaking fuel or fumes can come in contact with flames or sparks from electrical machines, electric engines, relays, switches, boilers or similar.
- Store the machine in a locked space away from children and adults untrained in use of the machine.

Children

Serious accidents can occur if you fail to be on guard for children in the vicinity of the machine. Never assume that children will stay put where you last saw them.

- Keep children away from the machine.
- Keep children away from the work area and under close supervision by another adult.
- Keep an eye out and shut off the machine if children enter the work area.
- Never allow children to operate the machine.
- Be particularly careful near corners, bushes, trees or other objects that block your view.

SAFETY

Fuel System



WARNING!

Gasoline and gasoline fumes are poisonous and extremely flammable. Be especially careful when handling gasoline, as carelessness can result in personal injury or fire.

- Only store fuel in containers approved for that purpose.
- Never remove the fuel cap and fill the fuel tank when the engine is running.
- Always stop the engine when refueling.
- Do not smoke when filling the gasoline tank and do not pour gasoline in the vicinity of sparks or open flame.
- Never fill the fuel tank indoors.
- Before starting the machine after refueling, it should be moved at least 10 feet (3 M) from the location where it was filled.
- Turn off the fuel supply for storage or transport.
- If leaks arise in the fuel system, the engine must not be started until the problem has been resolved
- Check the fuel level before each use and leave space for the fuel to expand, because the heat from the engine and the sun can otherwise cause the fuel to expand and overflow.
- Avoid overfilling. If you spill gasoline on the machine, wipe up the spill and wait until it has evaporated before starting the engine. If you spill gasoline on your clothing, change your clothing.

Maintenance

- Never make adjustments with the engine running.
- Disengage the drive units, shut off the engine and wait until all moving parts come to a complete stop before making adjustments, performing maintenance or cleaning the machine.
- Disconnect the spark plug cable before beginning repair work.
- Keep all components in serviceable condition and make sure all nuts, bolts, etc. are tight. Replace worn or damaged decals.
- Be careful when checking work tools. Use gloves when performing maintenance work.
- Never allow persons not trained in the use of the machine to perform service on it.
- Always park the machine on even ground before performing maintenance or making adjustments.
- Do not disassemble the engine. This can invalidate the engine warranty. Contact the dealer with any questions regarding service or guarantee matters. Follow all maintenance instructions.
- Do not change the setting of governors and avoid running the engine with overly high RPM. If you run the engine too fast, you risk damaging the machine components.
- Do not modify safety equipment. Check regularly to be sure it works properly. The machine must not be run with defective or disassembled safety equipment.
- The muffler is designed to maintain sound levels at an approved level and keep direct exhaust away from the user. Exhaust gases from the engine are extremely hot and may contain sparks that can cause fires or burn the user.
- Never use a machine with a defective muffler.
- Reduce the risk of fire by removing grass, leaves and other debris that may have caught in the machine.



WARNING!

Wait until all moving parts are completely still before performing maintenance on the machine. Turn off the engine and remove the spark plug cable.

ASSEMBLY

Bed Shaper and Cable Layer

1. Remove unit from box and pallet.
2. Fill unit engine with oil. Check engine manual for type and viscosity of oil.
3. Fill transmission with oil. Check engine manual for type and viscosity of oil.

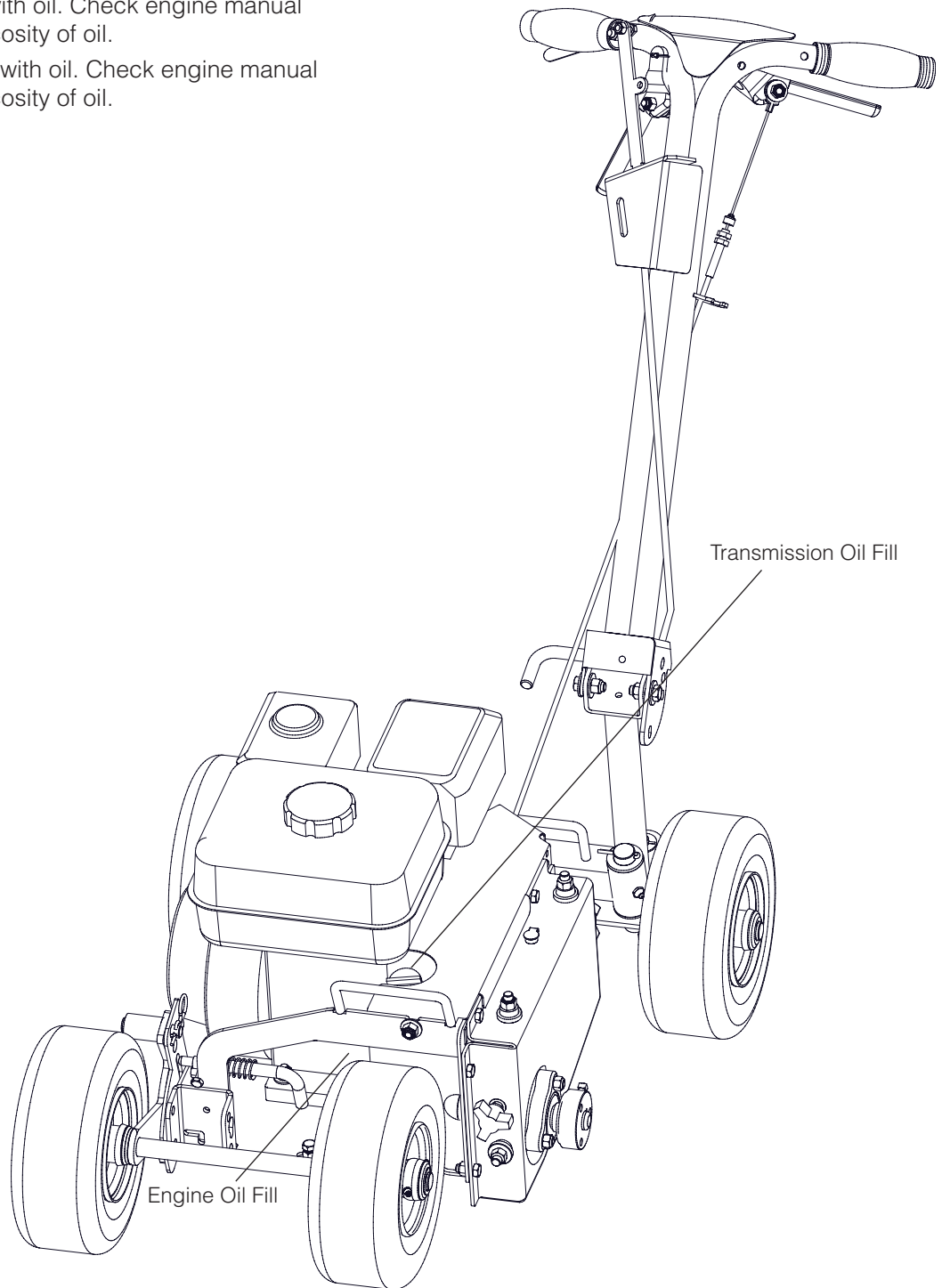

CONTROLS

Steering/Locking Handle

Located at the rear axle. Lift and rotate the lever clockwise to steer unit and counter clockwise to lock steering.

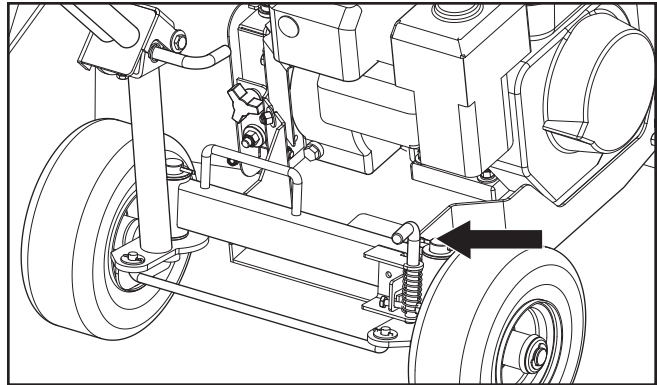

Handle Lock

Pull and hold lever, raise or lower the handle to desired position, then release lever. The lever can be locked back to allow a “floating” handle position if desired.

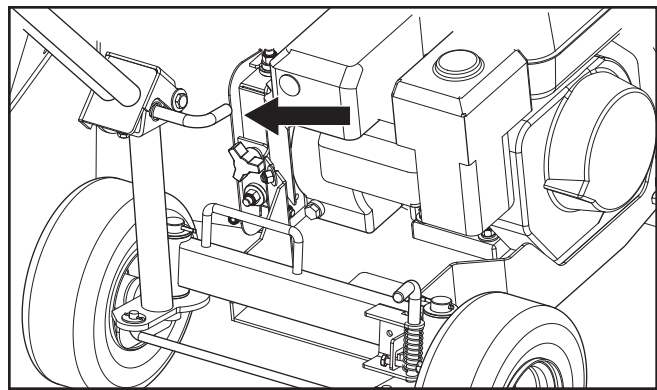

Throttle Lever

Pull right pistol to apply full throttle. The engine has a contained centrifugal clutch—increasing engine RPM above 2000 will engage the drive. Releasing the throttle lever brings engine back to idle speed and disengages drive.

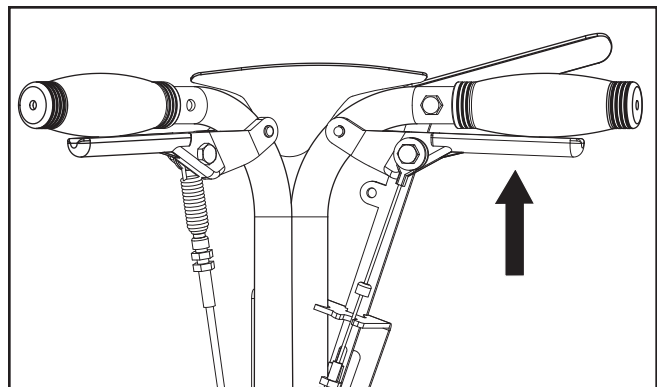

Depth Control Setting Plate

Three depth positions are available, 2", 3", 4" deep. Choose a depth position setting and pin axle lock in desired position. Place the unit into transport position. Pull the clevis pin out and slide the height plate until the desired depth lines up with the 2", 3" or 4" deep decal. Replace the pin, the 1/2" pin should line up with the desired setting.

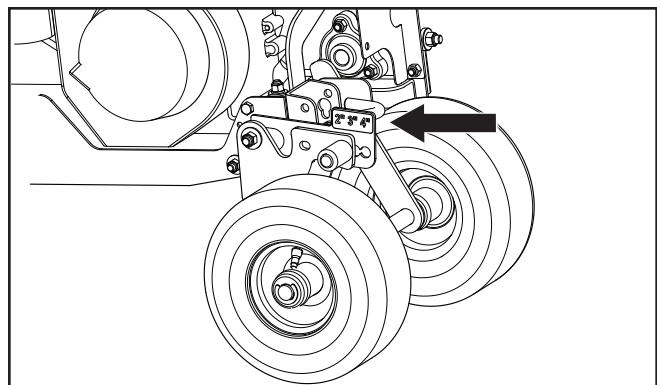

CONTROLS

Transport/Engaged Lever

To lock in transport position, pull left pistol and apply downward pressure.

When wheels begin to drop, release pistol, continue downward movement of handle until pin locks axle in transport position.

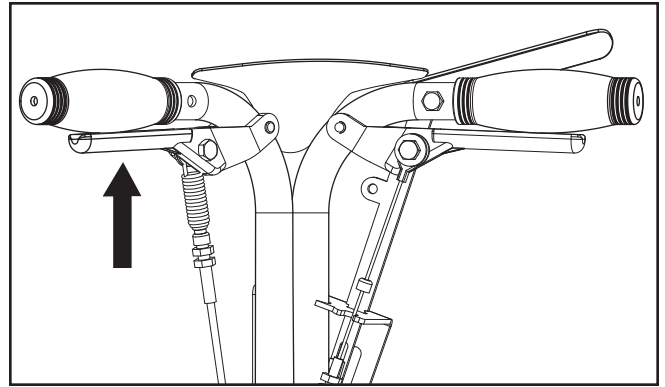

OPERATION

General

1. Do not allow the engine to “lug”. The engine should run at full RPM under load. Allow the engine to run at high RPM to maintain power level and solid clutch engagement while effectively cleaning the trench.
2. Lowering the RPM can cause the clutch to slip and raise the transmission oil temperature, possibly damaging the clutch.

IMPORTANT INFORMATION

**Clear the lawn of any debris.
Clearly mark rocks and other fixed objects.
Be especially sure to check for hidden
electrical cables or similar in the lawn.**

Bed Shaping

1. Clean the area to be worked. Create either a mental image of the border or paint an edge on the turf.
2. Check the machine for loose hardware. Fill engine with fuel.
3. Perform all settings and adjustments (found in the Controls section) on the machine.
4. Start out very slowly, learning the feel of the machine as you slowly pull the machine along the planned course.
5. If you must use the machine in wet or muddy conditions, clean the shield regularly.

MAINTENANCE

Maintenance Schedule

The following list of maintenance procedures must be performed on the machine. For those points not described in the manual, visit an authorized service workshop.

Maintenance	Daily before starting	Maintenance interval - hours			
		1/25	3/50	6/10	12/300
Check the engine oil level	■				
Replace engine oil ¹⁾				■	
Check the air filter	■				
Clean the air filter ²⁾			■		
Replace air filter cartridge ²⁾					■
Clean sludge reservoir for fuel system				■	
Check and clean the spark plug				■	
Replace the spark plug					■
Check idle speed					■
Check and adjust play in valves ⁴⁾					◆
Clean fuel tank ⁴⁾					◆
Check, replace fuel lines as necessary ^{4, 5)}					◆
Check throttle cable	◆				
Check decals and warning signs	◆				
Check wear and tension on the chain		■			
Check the chassis, bolts and set screws			◆		
Lubrication; see the Lubrication schedule					

¹⁾ First change after 20 hours. ²⁾ In dusty conditions maintenance is required at shorter intervals. ³⁾ With daily use, the machine shall be lubricated twice weekly. ⁴⁾ Performed by authorized service workshop. ⁵⁾ Performed every second year.

- Described in this manual
- ◆ Not described in this manual



WARNING!

No service operations may be performed on the engine or unit unless:

- **The engine is stopped.**
- **The ignition cable has been removed from the spark plug.**
- **The machine is securely parked where it will not tip or begin rolling.**

MAINTENANCE

Drive Chain

Tightening

1. Allow engine to cool. Remove spark plug cable.
2. Remove guard only.
3. Using a $\frac{9}{16}$ wrench and a $\frac{9}{16}$ socket wrench, loosen the mounting idler bolt. Slide up to tension chain, retighten bolt.

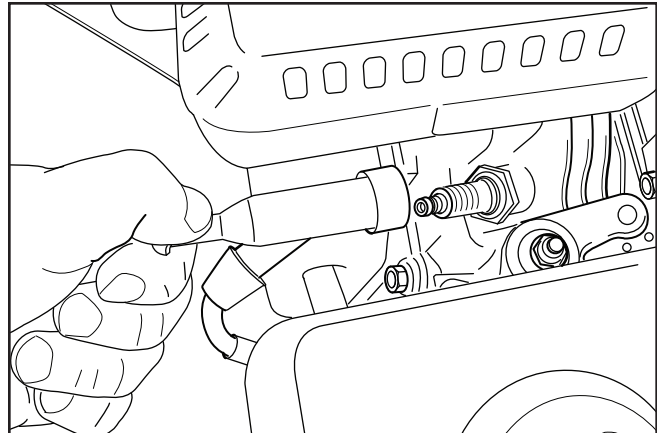

Checking Drive Chain And Sprockets

1. Allow engine to cool. Remove spark plug cable.
2. Remove the guard, cutting head, chain cover and transmission cover.
3. DO NOT remove mounting hub from shaft.
4. Check that the chain is running in the proper track; the sprockets should guide the chain in a straight line.
5. Check the chain for cracks, heat damage or worn edges. If these symptoms appear, replace the drive chain; see *Replacing the Drive Chain*.
6. Check that the tensioning equipment for the chain is not loose and is properly set; see *Replacing the Drive Chain*.
7. Refit the chain cover, transmission cover, cutting head and shield.

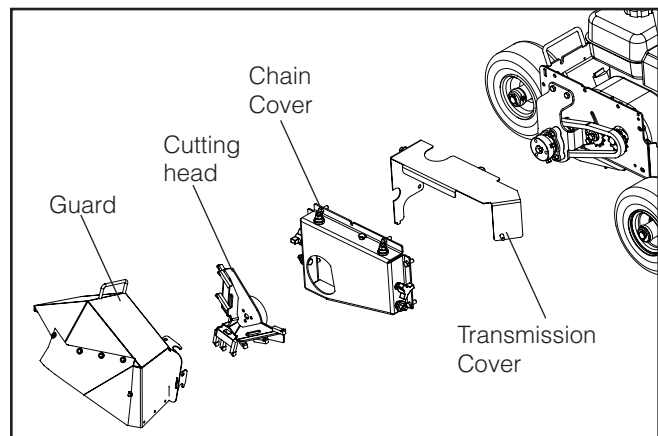

MAINTENANCE

Replacing the Drive Chain

1. Allow engine to cool. Remove spark plug cable.
2. Remove the guard, transmission cover, cutting head and chain cover.
3. Remove old chain.
4. Check for wear on sprockets and replace as necessary.
5. Check engine sprocket alignment to shaft driven sprocket and adjust as necessary. The chain should run straight.
6. Fit a new chain, the chain tensioner should maintain $\frac{1}{8}$ " movement in the lower chain (maximum).
NOTE: Master link MUST face correct direction or it may come off.
7. Replace transmission cover, chain cover, cutting head and guard.

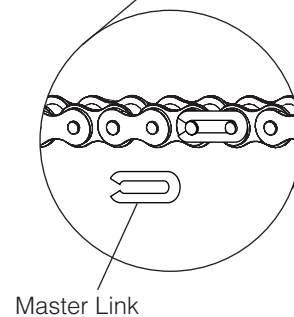
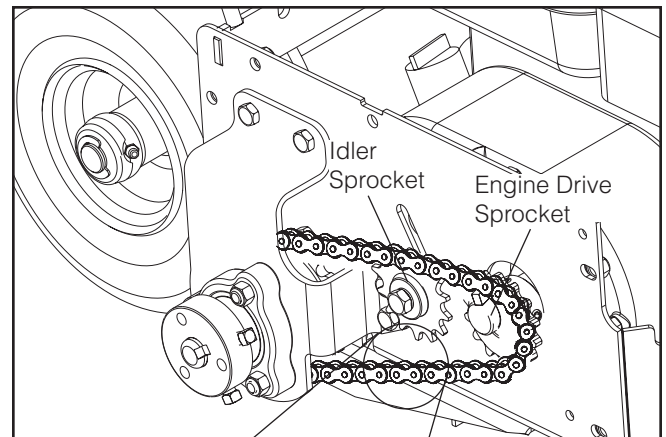

Cleaning

Regular cleaning will increase the machine's lifespan. Clean the machine directly after use, before the dirt sticks. Check before rinsing that the fuel tank lid is properly in place to avoid getting water in the tank. Use caution when using high-pressure spray because warning decals, instruction signs and the engine can be damaged. **Do not exceed 70 bar/ 1000 PSI** water pressure when cleaning.

Lubricate the machine after cleaning. This is particularly important if the machine is to be stored. Oil the chain after every cleaning, grease the bearing zerks and the front axle spindle bushing zerks.

Service

When ordering spare parts, please specify the purchase year, model, type, and serial number. The chain on this unit is a high quality permalube type. DO NOT replace with a simple roller chain. Oil chain and sprockets per lube schedule. Always use genuine BlueBird spare parts. An annual check-up at an authorized service workshop is a good way to ensure that your machine performs its best the following season.

MAINTENANCE

Storage

At the end of the season, (or if it will not be in use for longer than 30 days) the machine should be readied for storage. Fuel allowed to stand for long periods of time (30 days or more) can leave sticky residues that can plug the carburetor and disrupt engine function. Fuel stabilizers are an acceptable option to reducing sticky residues during storage. If alkylate gasoline (Aspen) is used, stabilizers are unnecessary because this fuel is stable. However, you should avoid switching between regular and alkylate gasoline as sensitive rubber components can harden. Add stabilizer to the fuel in the tank or in the storage container. Always use the mixing ratios specified by the manufacturer of the stabilizer. Run the engine for at least 10 minutes after adding the stabilizer so that it reaches the carburetor. Do not empty the fuel tank and the carburetor if you have added stabilizer.

To ready the machine for storage, follow these steps:

1. Clean the machine carefully, particularly the chassis and working equipment. Mend damage to the paint to prevent rust.
2. Inspect the machine for worn or damaged parts and tighten any nuts or bolts that may have become loose.
3. Change the engine oil; dispose of properly.
4. Open the fuel valve. Empty the fuel tank and the carburetor. (For specific instructions, refer to the Engine Manual).
5. Close the fuel valve.
6. Remove the spark plug and pour about a tablespoon of engine oil in the cylinder. Turn over the engine so that the oil is evenly distributed and then refit the spark plug. Put the engine in the compression phase where the triangle mark on the sleeve of the starter is aligned with the upper hole in the starter.
NOTE: Compression phase occurs every second revolution.
7. Lubricate all grease zerks, joints and chains as described in the chapter **Lubrication**.
8. Store the machine in a clean, dry place and cover it for extra protection.



WARNING!

Never store an engine with fuel in the tank indoors or in poorly ventilated spaces where fuel vapor can come in contact with open flame, sparks or a pilot light such as in a boiler, hot water tank, clothing dryer, etc. Handle the fuel with caution. It is very flammable and careless use can cause serious damage to person and property. Drain the fuel into an approved container outdoors and far away from open flame. Never use gasoline for cleaning. Use a degreaser and warm water instead.

LUBRICATION

General

Stop the engine and remove the spark plug cable before attempting to lubricate the machine. Wipe away excessive grease after lubrication.

Lubrication schedule

1. Check engine oil daily, change every six months or 100 hours.
2. Check and lubricate wheel bearings once a month. Lubricate chain once a week or every 20 hours.
NOTE: Spin the cutting head slowly by hand to distribute the oil onto the chain and sprockets.
3. Lubricate the (kingpin bushings) once a month.
4. Grease the bearings on the cutter shaft once a week or every 20 hours.
NOTE: The chain supplied is a quality permalube chain, but it **MUST** be oiled by the user each 20 hours to keep the sprockets and chain lubricated. Failing to oil the chain will cause premature failure of the chain and sprockets.
5. Check oil in transmission regularly. Refill if required. Use same oil in transmission as engine. See engine owners manual.

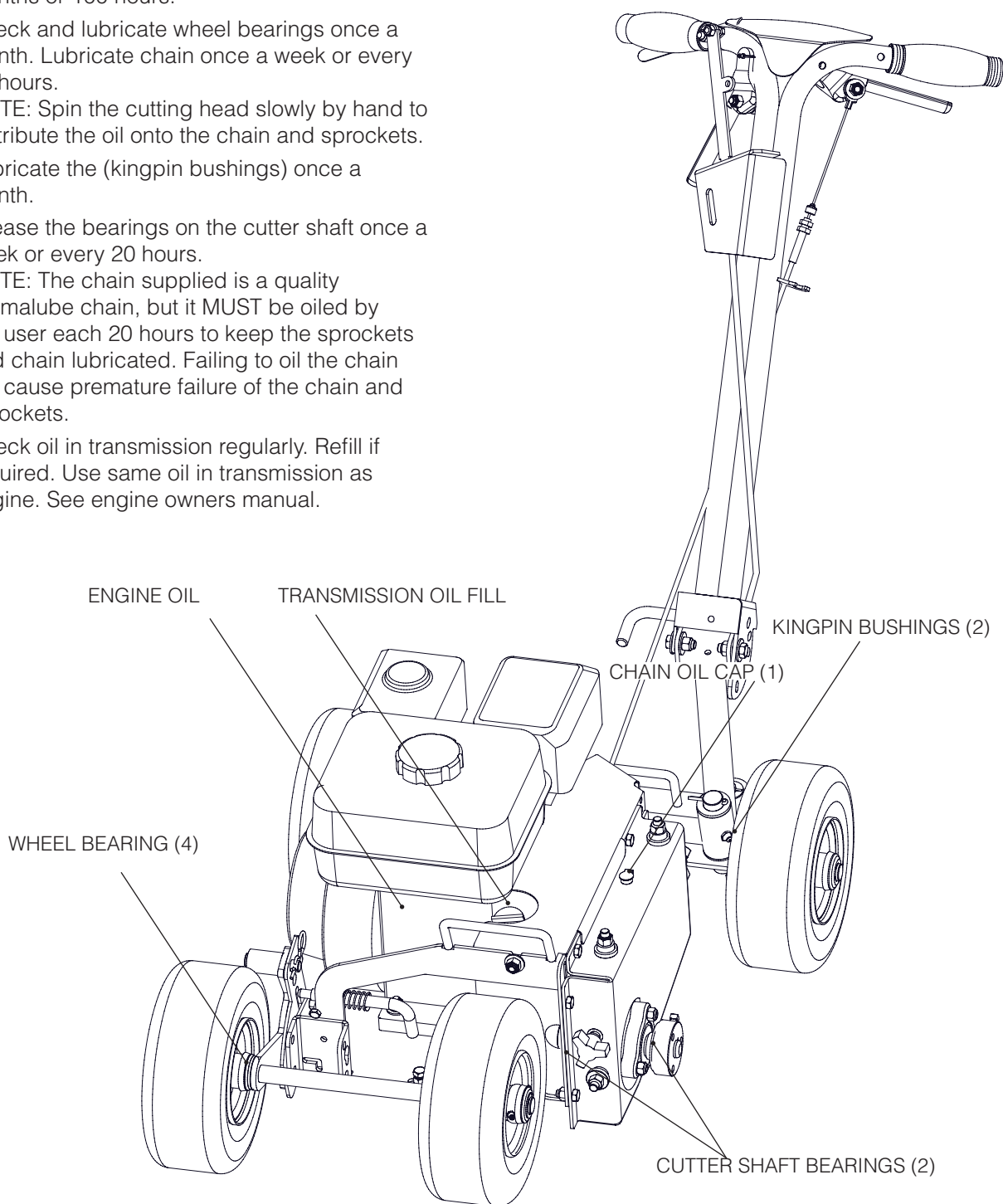

TROUBLESHOOTING

Symptom	Cause	Action
Engine will not start		
User error	Fuel valve closed.	Open the fuel valve.
	Choke valve open	Close the choke with cold engine.
	Operator presence switch not held down	Move to operator position and hold down
Fuel system	Fuel tank empty	Fill with fuel
	Machine stored without observing proper procedure from chapter Storage	Clean tank, sludge reservoir and empty carburetor. Fill the tank with fresh fuel.
	Contamination, water or ice in fuel system.	Clean tank, sludge reservoir and empty carburetor. Fill the tank with fresh fuel.
	Carburetor problems	Contact an authorized service workshop
Spark plug	Wrong spark plug type	Replace the spark plug
	Build-up on electrodes, short circuit	Check electrode gap and clean or replace spark plug
	Gasoline or oil on the spark plug	Clean the spark plug. Air the engine out. Start with full throttle.
No spark after checking spark plug	Faulty engine switch, cable or ignition	Contact authorized service workshop
Low compression	Serious interior engine damage or faulty valves	Contact authorized service workshop

TROUBLESHOOTING

Symptom	Cause	Action
Engine is under-powered or runs unevenly		
Air filter	Clogged air filter	Clean or replace the air filter
Fuel system	Machine stored without observing proper procedure from chapter Storage	Clean tank, sludge reservoir and empty carburetor. Fill the tank with fresh fuel.
Blue or voluminous blue-white exhaust	Contaminated or incorrect fuel	Clean tank, sludge reservoir and empty carburetor. Fill the tank with proper fuel.
Black exhaust	Choke left on	Open choke valve
	Clogged air filter	Clean or replace the air filter
	Carburetor problems	Contact authorized service workshop.
Ignition system	Wrong spark plug type	Replace the spark plug
	Build-up on electrodes, short circuit	Check electrode gap and clean or replace spark plug.
	Faulty ignition unit	Contact authorized service workshop.
Low compression	Serious interior engine damage or faulty valves	Contact authorized service workshop.

SERVICE JOURNAL

Action	Date, stamp, signature
Delivery Service	
1. Break the packaging and make sure the machine has not been damaged in transport.	<input type="checkbox"/>
2. Where applicable, assemble accompanying components.	<input type="checkbox"/>
3. Check that machine design corresponds to customer order.	<input type="checkbox"/>
4. Check that the right amount of oil is in the engine and transmission.	<input type="checkbox"/>
5. Check that the working equipment is properly set.	<input type="checkbox"/>
6. Check that the drive sprockets are aligned.	<input type="checkbox"/>
7. Check that the chain is properly adjusted.	<input type="checkbox"/>
8. Lubricate machine as described in lubrication schedule.	<input type="checkbox"/>
9. Fill the fuel tank and start the engine.	<input type="checkbox"/>
10. Check all operating instruments.	<input type="checkbox"/>
11. Check decals and information attached to the unit.	<input type="checkbox"/>
12. Check the engine speed (RPM), see Technical Data.	<input type="checkbox"/>
13. Check for leakage.	<input type="checkbox"/>
14. Inform the customer about:	<input type="checkbox"/>
The need and advantages of following the service schedule.	<input type="checkbox"/>
The need and advantages of leaving the machine for service every 300 hours.	<input type="checkbox"/>
The effects of service and maintaining a service journal on the machine's resale value.	<input type="checkbox"/>
15. Fill in the sales papers, etc.	<input type="checkbox"/>
	Delivery service has been carried out. No remaining notes. Certified:
<hr/>	
After the first 20 hours	
1. Change engine oil.	<input type="checkbox"/>
2. Check that the chain is properly adjusted.	<input type="checkbox"/>
3. Tighten screws and nuts.	<input type="checkbox"/>
4. Check the oil in the clutch case.	<input type="checkbox"/>
5. Lubricate per lubrication schedule	<input type="checkbox"/>

SERVICE JOURNAL

Action

Date, stamp, signature

