

OPERATION AND PARTS MANUAL



MODEL DM15A9C CORE DRILL MOTOR & MODEL CDM2CSA DRILL RIG STAND

Revision #1 (11/09/05)

To find the latest revision of this
publication, visit our website at:
www.multiquip.com



THIS MANUAL MUST ACCOMPANY THE EQUIPMENT AT ALL TIMES.



WARNING



CALIFORNIA — Proposition 65 Warning

Engine exhaust and some of its constituents, and some dust created by power sanding, sawing, grinding, drilling and other construction activities contains chemicals known to the State of California to cause cancer, birth defects and other reproductive harm. Some examples of these chemicals are:

- Lead from lead-based paints.
- Crystalline silica from bricks.
- Cement and other masonry products.
- Arsenic and chromium from chemically treated lumber.

Your risk from these exposures varies, depending on how often you do this type of work. To reduce your exposure to these chemicals: **ALWAYS** work in a well ventilated area, and work with approved safety equipment, such as dust masks that are specially designed to filter out microscopic particles.

WARNING



SILICOSIS WARNING

Grinding/cutting/drilling of masonry, concrete, metal and other materials with silica in their composition may give off dust or mists containing crystalline silica. Silica is a basic component of sand, quartz, brick clay, granite and numerous other minerals and rocks. Repeated and/or substantial inhalation of airborne crystalline silica can cause serious or fatal respiratory diseases, including silicosis. In addition, California and some other authorities have listed respirable crystalline silica as a substance known to cause cancer. When cutting such materials, always follow the respiratory precautions mentioned above.

WARNING

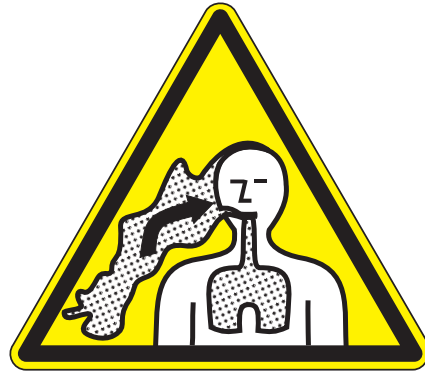

RESPIRATORY HAZARDS

Grinding/cutting/drilling of masonry, concrete, metal and other materials can generate dust, mists and fumes containing chemicals known to cause serious or fatal injury or illness, such as respiratory disease, cancer, birth defects or other reproductive harm. If you are unfamiliar with the risks associated with the particular process and/or material being cut or the composition of the tool being used, review the material safety data sheet and/or consult your employer, the material manufacturer/supplier, governmental agencies such as OSHA and NIOSH and other sources on hazardous materials. California and some other authorities, for instance, have published lists of substances known to cause cancer, reproductive toxicity, or other harmful effects.

Control dust, mist and fumes at the source where possible. In this regard use good work practices and follow the recommendations of the manufacturers or suppliers, OSHA/NIOSH, and occupational and trade associations. Water should be used for dust suppression when wet cutting is feasible. When the hazards from inhalation of dust, mists and fumes cannot be eliminated, the operator and any bystanders should always wear a respirator approved by NIOSH/MSHA for the materials being used.

Multiquip DM15A9C Electric Powered Core Drill and CDM2CSA Drilling Rig

Proposition 65 Warning	2
Silicosis Warning	3
Table Of Contents	4
Parts Ordering Procedures	5
Safety Message Alert Symbols	6
Rules For Safe Operation	7-9
General Information	10-11
Specifications/Dimensions(DM15A9C)	12
Dimensions (CDM2CSA)	13
Components (CDM2CSA Drilling Rig)	14
Components (DM15A9C Electric Motor)	14
Pre-Set-up	16-20
Operation	21
Shutdown	22
Maintenance	23
Troubleshooting	24
Explanation Of Code In Remarks Column	26
Suggested Spare Parts	27
Nameplate and Decals	28-29
Electric Motor Assembly	30-33
Drilling Rig Assembly	34-35
Cradle Assembly	36-37
Tools	38-39
Terms and Conditions of Sale	40

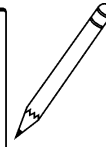
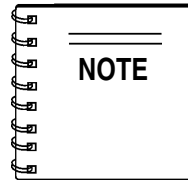

*As a continuing effort to update our parts book, contact the **MULTIQUIP** literature department for the latest revision of your "Operation and Parts Manual"*

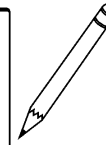
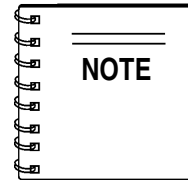

Specification and part number are subject to change without notice.

DM15A9C/CDM2CSA — PARTS ORDERING PROCEDURES

www.multiquip.com

Ordering parts has never been easier! Choose from three easy options:



Order via Internet (Dealers Only):

Order parts on-line using Multiquip's SmartEquip website!

- View Parts Diagrams
- Order Parts
- Print Specification Information



If you have an MQ Account, to obtain a Username and Password, E-mail us at: parts@multiquip.com.

To obtain an MQ Account, contact your District Sales Manager for more information.

Goto www.multiquip.com and click on **Order Parts** to log in and save!

Use the **internet** and qualify for a **5% Discount** on *Standard orders* for all orders which include complete part numbers.*

Note: Discounts Are Subject To Change



Order via Fax (Dealers Only):

All customers are welcome to order parts via Fax.

Domestic (US) Customers dial:
1-800-6-PARTS-7 (800-672-7877)

Fax your order in and qualify for a **3% Discount** on *Standard orders* for all orders which include complete part numbers.*

Note: Discounts Are Subject To Change



Order via Phone: Domestic (US) Dealers Call:
1-800-427-1244

Non-Dealer Customers:

Contact your local Multiquip Dealer for parts or call 800-427-1244 for help in locating a dealer near you.



International Customers should contact their local Multiquip Representatives for Parts Ordering information.

When ordering parts, please supply:

- | | |
|---|--|
| <input type="checkbox"/> Dealer Account Number | <input type="checkbox"/> Specify Preferred Method of Shipment: |
| <input type="checkbox"/> Dealer Name and Address | <input checked="" type="checkbox"/> Fed Ex/UPS <input checked="" type="checkbox"/> DHL |
| <input type="checkbox"/> Shipping Address (if different than billing address) | <input type="checkbox"/> Priority One <input checked="" type="checkbox"/> Truck |
| <input type="checkbox"/> Return Fax Number | <input type="checkbox"/> Ground |
| <input type="checkbox"/> Applicable Model Number | <input type="checkbox"/> Next Day |
| <input type="checkbox"/> Quantity, Part Number and Description of Each Part | <input type="checkbox"/> Second/Third Day |

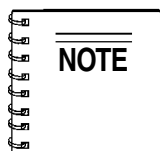

Unless otherwise indicated by customer, all orders are treated as *Standard Orders* and will ship within 24 hours. We will make every effort to ship *Air Shipments* the same day the order is received, if received prior to 2PM PST. *Stock Orders* must be noted on fax or web order form.

WE ACCEPT ALL MAJOR CREDIT CARDS!



DM15A9C/CDM2CSA—SAFETY MESSAGE ALERT SYMBOLS

FOR YOUR SAFETY AND THE SAFETY OF OTHERS!

Safety precautions should be followed at all times when operating this equipment. Failure to read and understand the Safety Messages and Operating Instructions could result in injury to yourself and others.

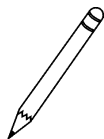
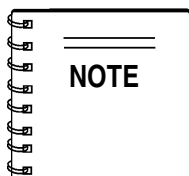

This Operation and Parts Manual has been developed to provide complete instructions for the safe and efficient operation of the **MQ Models DM15A9C/CDM2SA Core Drill Motor and Drill Rig**

Before using this core drill stand and electric motor, ensure that the operating individual has read and understands all instructions in this manual.

SAFETY MESSAGE ALERT SYMBOLS

The three (3) Safety Messages shown below will inform you about potential hazards that could injure you or others. The Safety Messages specifically address the level of exposure to the operator, and are preceded by one of three words: **DANGER**, **WARNING**, or **CAUTION**.

DANGER

You **WILL** be **KILLED** or **SERIOUSLY** injured if you **DO NOT** follow directions.

WARNING

You **CAN** be **KILLED** or **SERIOUSLY** injured if you **DO NOT** follow directions.

CAUTION

You **CAN** be **INJURED** if you **DO NOT** follow directions.

HAZARD SYMBOLS

Potential hazards associated with the operation of the **DM15A9C (electric motor) and MQ CDM2CSA (drill rig)** will be referenced with Hazard Symbols which appear throughout this manual, and will be referenced in conjunction with Safety Message Alert Symbols.



WARNING - Respiratory Hazards

ALWAYS wear approved **respiratory** protection when required.



CAUTION - Eye and Hearing Hazards

ALWAYS wear approved eye and hearing protection.

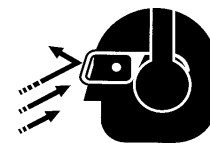

CAUTION - Accidental Starting Hazards

ALWAYS place the core-drill's **ON/OFF** switch in the **OFF** position when the drill is not in use.



CAUTION - Over Speed Conditions

NEVER tamper with the factory settings of the core drill. Personal injury and damage to the core drill can result if operating in speed ranges above maximum allowable.



CAUTION - Rotating Drill Bit

Rotating drill bit can cut and crush. Keep hands and feet clear.



CAUTION - Equipment Damage Hazards

Other important messages are provided throughout this manual to help prevent damage to your drill, other property, or the surrounding environment.

DM15A9C/CDM2CSA— RULES FOR SAFE OPERATION

DANGER

Read this manual!

Failure to follow instructions in this manual may lead to serious injury or even death! This equipment is to be operated by trained and qualified personnel only! This equipment is for industrial use only.

The following safety guidelines should always be used when operating the **MQ DM15A9C (electric motor) and CDM2SA (drill rig)**

GENERAL SAFETY

- **DO NOT** operate or service this equipment before reading entire manual.
- This equipment should not be operated by persons under 18 years of age.
- **NEVER** operate this equipment without proper protective clothing, shatterproof glasses, steel-toed boots, hard hat and other protective devices required by the job.



- **NEVER** operate this equipment when not feeling well due to fatigue, illness or taking medicine.
- **NEVER** operate this equipment under the influence of **drugs** or **alcohol**.



- **ALWAYS** wear proper respiratory (mask), hearing and eye protection equipment when operating the core drill.
- Whenever necessary, replace nameplate, operation and safety decals when they become difficult to read.
- Manufacturer does not assume responsibility for any accident due to equipment modifications.
- **NEVER** use accessories or attachments, which are not recommended by Multiquip for this equipment. Damage to the equipment and/or injury to user may result.



- **NEVER** operate the core drill in an explosive atmosphere or near combustible materials. The electric motor of this core-drill emits sparks during operation and shut-down. A explosion or fire could result causing severe **bodily harm or even death** if the sparks make contact with combustible or explosive materials.
- Maintain this equipment in a safe operating condition at all times.
- Keep bystanders, children and visitors away while operating the core drill. Distractions can cause you to lose control.
- **DO NOT** wear loose clothing or jewelry. Contain long hair. Keep your hair, clothing, and gloves away from moving parts.
- **ALWAYS** store equipment properly when it is not being used. Equipment should be stored in a clean, dry location out of the reach of children.
- **ALWAYS** be sure the operator is familiar with proper safety precautions and operation techniques before using core drill.
- **ALWAYS** keep work area clean and free of foreign matter and debris. Also keep work area well lit.
- Avoid accidental starting. Make sure power **ON/OFF** switch is off before applying power.
- **NEVER** leave the core drill unattended. When not in use always unplug the core drill from power source.
- **ALWAYS** remove any adjusting keys or wrenches before turning the core drill on. A wrench or key that is left attached to the rotating part of the core drill may result in personal injury.
- **DO NOT** overreach. Keep proper footing and balance at all times. Proper footing and balance enables better control of the core drill in unexpected situations.
- Keep all **inexperienced** and **unauthorized** people away from the equipment at all times.
- Become familiar with the components of the core drill before operating.
- **ALWAYS** replace any worn or damaged warning decals.
- **NEVER** touch drill bit cutting edges during operation. Also allow drill bit a sufficient amount of time to cool before touching.

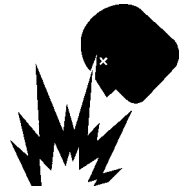

DM15A9C/CDM2CSA — RULES FOR SAFE OPERATION

- Maintain the core drill and drill bits with care. Make sure bit maintains good diamond exposure. A dull bit will cause glazing.
- **NEVER** drill into a work piece that is not secured.
- Use this core drill only for its intended purpose. **DO NOT** use this core drill for applications not recommended.
- Inspect the drill after each use. Replace any damaged or worn parts immediately. **DO NOT** use a defective core-drill.
- **NEVER** cover the air vents on the body of the core drill. **ALWAYS** leave these vents exposed. These vents are essential for the cooling of the electric motor. **NEVER** place tape over the vent to keep out dust.
- If a malfunction occurs, immediately unplug the core drill from the power source and correct the problem. If the problem can not be corrected, contact your nearest MQ service center.
- **DO NOT** force your core drill. Exerting excessive force while drilling will damage your machine and is hazardous.
- **ALWAYS** make sure drill bit is installed securely so that it will not slip or fall out. It is hazardous to use a core drill with a loose fitted drill bit.
- Some materials contain chemicals which may be toxic. Take precautions to prevent dust inhalation and skin contact.
- When connecting the core drill to a power receptacle, make sure the receptacle circuit is connected to either a GFCI receptacle or a receptacle protected by a 20 amp circuit breaker.
- When plugging the core-drill into a power receptacle, check the nameplate for the correct operating voltage. Operating the core drill at the wrong voltage will damage the electric motor. **ALWAYS** read the nameplate before applying power.
- This core drill is equipped with a 3-prong male power plug. **DO NOT** use a 2-prong adapter when plugging into a wall outlet. This will defeat the purpose of the ground circuit. If the plug does not fit into the receptacle, contact a qualified electrician to install a 3-conductor wall receptacle (outlet).
- Avoid body contact with grounded surfaces such as pipes, radiators, ranges and refrigerators. There is an increased risk of electrical shock if your body is grounded.
- **DO NOT** expose the the core drill to rain or wet conditions. Water entering the drill wii increase the risk of electrical shock.
- When operating the core drill outside, be sure to use the appropriate outdoor extension cord. This type of extension cord reduces the risk of electrical shock.
- **ALWAYS** be on the lookout for hidden wiring, the possibility exists of the drill bit making contact with hidden wiring. Contact with a "live" wire can cause electrical shock to the operator.
- **ALWAYS** remove the AC power cord from the power source before performing any service or maintenance on the core drill. This preventative safety measure reduces the possibility of accidental starting.

ELECTRICAL SAFETY

- **ALWAYS** test the **ON/OFF** switch on the core drill before operating. The purpose of this switch is to shut down the electric motor.
- **NEVER** use a extension cord that is frayed or damaged where the insulation has been cut.
- **NEVER** carry the core drill by its power cord or disconnect it by yanking the cord from the power outlet.
- **ALWAYS** make certain that the proper extension cord has been selected for the job. See Table 1.
- **NEVER** allow power cord to *lay in water*.
- **NEVER** *stand in water* while operating the core drill.

DM15A9C/CDM2CSA— RULES FOR SAFE OPERATION

TRANSPORTING

- **ALWAYS** secure the core drill and drill rig with rope or tie-downs when transporting is required.
- **ALWAYS** wrap power cord neatly to avoid damage.
- **ALWAYS** place wrenches in a safe location where they can be located easily. Keep tools clean.

MAINTENANCE

- **NEVER** lubricate components or attempt service on a running core drill.
- **ALWAYS** allow the core drill a proper amount of time to cool before servicing.
- Keep the core drill in proper running condition.
- Fix damage to the core drill immediately and always replace broken parts. Replace with only MQ recommended parts.

EMERGENCIES

- **ALWAYS** know the location of the nearest *fire extinguisher* and *first aid kit*.

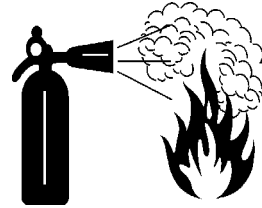

- In emergencies *always* know the location of the nearest phone or *keep a phone on the job site*. Also know the phone numbers of the nearest *ambulance*, *doctor* and *fire department*. This information will be invaluable in the case of an emergency.

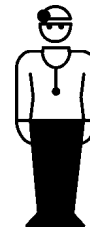

DM15A9C/CDM2CSA — GENERAL INFORMATION

APPLICATION

The **MQ DM-15A9C Stationary Core Drill Motor** is designed to be used with the **MQ CDM-2CSA Lightweight Drilling Rig**. The core drill motor is intended only for wet drilling applications involving concrete type materials. Up to 9-inch (229 mm) diameter holes can be drilled for **wet** drilling applications using **standard** MQ wet drill bits. All MQ wet drill bits allow for a **14-inch cutting depth**. Dry cutting applications are not recommended with this unit.

Power Plant

The MQ DM-15A9C is powered by a 120 VAC 2-speed electric motor @ 15 amps. Min/Max RPM's is 600/ 1200 . The unit weighs 20.0 lbs (9.0 kg.)

Features

This unit is equipped with the following:

- 2-Speed Electric Motor
- Internal Water Feed System
- Vacuum Pump (Option)

Standard MQ Drill Bits (Wet)

This core drill can use the following series of wet drilling bits:

- **GCB Series** – economy quality small jobs.
- **GB Series** – standard quality small to mid-size jobs.
- **PRB Series** – premium quality for fast speeds.
- **PCB Series** – super premium quality and long life.
- **PCB Series** – pro quality, high steel content and extremely hard aggregate small jobs.

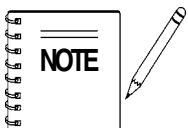

Contact the MQ Sales Department for the core drill bit that best fits your application or accessories.

Threads/Adapters

The MQ DM15A9C core drill is supplied with a 1-1/4" X 7 thread shaft to be used specifically with the Multiquip wet drill bits. If it ever becomes necessary to reduce the shaft size, a 5/8" X11 reducer is available as an option.

Supplied Tools

- 17, 19, 36 and 46 mm wrenches

Extension Cords

Use only 3-prong type extension cords with grounding pin. Always connect extension cord to a matching 3-prong receptacle. **NEVER** use a 3 to 2 prong adapter, this type of adapter will defeat the ground circuit protection capability. Always use an extension cord of adequate current carrying capability. Use Table 1 as a guideline when selecting the proper extension cord.

! DANGER - ELECTROCUTION HAZARDS

During operation of this core drill, there exists the possibility of **electrocution, electrical shock or burn**, which can cause **severe bodily harm** or even **DEATH!**



To avoid these hazards:

NEVER use damaged or worn cables when plugging the core drill into an AC power receptacle.

NEVER grab or touch a live power cord with wet hands.

NEVER stand in water and touch a live power cord.

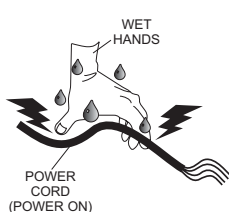

Table 1. Cable Selection (60 Hz, Single Phase Operation)

Current in Amperes	Load In Watts At 120 Volts	Maximum Allowable Cable Length			
		#10 Wire	#12 Wire	#14 Wire	#16 Wire
2.5	300	1000 ft.	600 ft.	375 ft.	250 ft.
5	600	500 ft.	300 ft.	200 ft.	125 ft.
7.5	900	350 ft.	200 ft.	125 ft.	100 ft.
10	1200	250 ft.	150 ft.	100 ft.	
15	1800	150 ft.	100 ft.	65 ft.	
20	2400	125 ft.	75 ft.	50 ft.	

CAUTION: Equipment damage can result from low voltage.

Operator Technique

Always drill with consistent uniform pressure. **NEVER** subject the drill bit to sudden impacts. Uneven pressure can damage a bit. Slow bit penetration leads to bit glazing. Excessive drill pressure can overload the drill motor. Always try and let the drill bit do the work and try not to force the bit through the material.

If vibration occurs while drilling do the following:

- Stop drilling
- Turn motor off
- Check for loose nuts or bolts on the equipment
- Check for bit runout. Replace if necessary

Drilling Performance

Factors that influence core drilling:

- Amount of water flow
- Condition of equipment
- RPM of electric drill motor
- Amount and size steel
- Age of concrete
- Aggregate (size, type, hardness, abrasiveness)
- Operator technique
- Bit runout

Bit Glazing

Bit binding is caused by either a dull (glazed) bit or a poorly stabilized drilling rig. The causes of glazing are as follows:

- Wrong RPM for drill bit diameter
- Excessive feed pressure
- Low feed pressure
- High steel content in material work surface
- Large hard aggregate
- Too much water
- Low electric motor RPM's

Water

Water acts as a coolant, eliminating the heat caused by the friction of the drilling. This preserves the integrity of the drill bit. Without water acting as a coolant, the heat buildup during drilling will greatly reduce the life cycle of the drill bit.

During drilling water flushes loose, abrasive particles created during drilling. These particles consist of aggregate, sand, and various metals from embedded steel. The hole must be free of debris to allow the core bit to work.

If loose particles are not properly flushed from the hole, an unnecessary drag will occur along the side of the core barrel. This can contribute to bit glazing (less power) and damage to the electric motor. In addition loose particles contribute to premature bit wear.

Monitor water flow continuously. Water volume should be adjusted until water return is muddy. Clear streaks indicate too much water volume. Excessive water volume is the leading cause of bit glazing. Excessive water prevents adequate segment material contact. When the bit segments do not make proper contact with the work surface (hydro-planing) they begin to glaze. Adequate water volume varies according to bit diameter. Use only enough water during drilling to flush particles from the work surface.

DM15A9C — SPECIFICATIONS/DIMENSIONS (MOTOR)

Table 2. Electric Motor Specifications

	Model	DM15A9C
Core Drill Motor	Motor	120 VAC, 60 Hz @ 600 RPM (low speed, 1200 RPM (high speed)
	Current	15 amps
	Watts	1,800
	Applicable Drill Bit Diameter Standard Wet Drill Bits	1~9 inches (25.4-228.6 mm)
	Dry Net Weight	20 lbs. (9.07 Kg.)

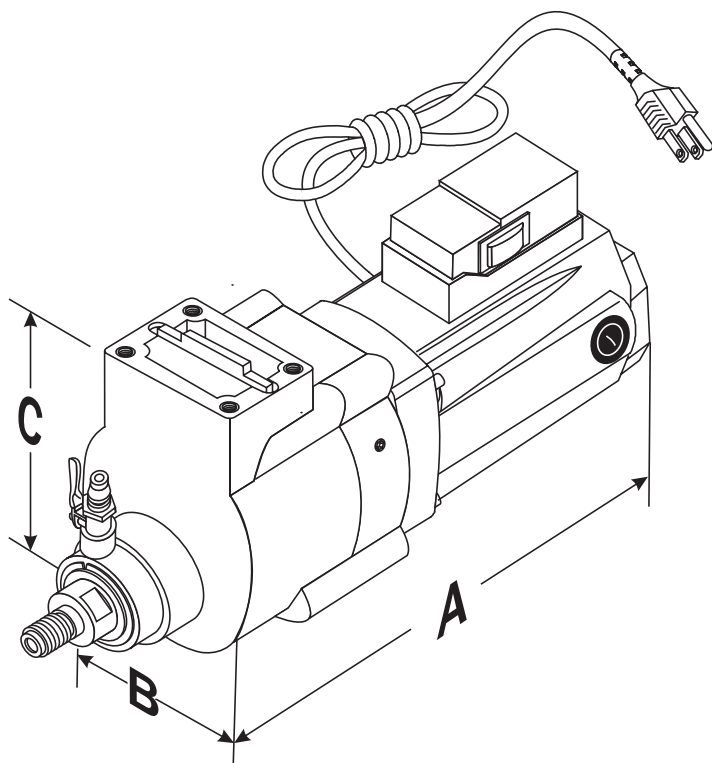

Table 3. DM15A9C Dimensions

A (Length)	18.75 in. (476.25 mm)
B (Width)	8.25 in. (209.55 mm)
C (Height)	6.00 in. (152.40 mm)

Figure 1. DM15A9C Electric Motor Dimensions

CDM2CSA — DIMENSIONS (DRILLING RIG)

Table 4. CDM2CSA Dimensions

A (Total Length)	23.75 in. (603.25 mm)
B (Width)	12.25 in. (311.15 mm)
C (Height)	40.5 in. (1028 mm)
D (Length To Rear Wheels)	18 in. (457 mm)

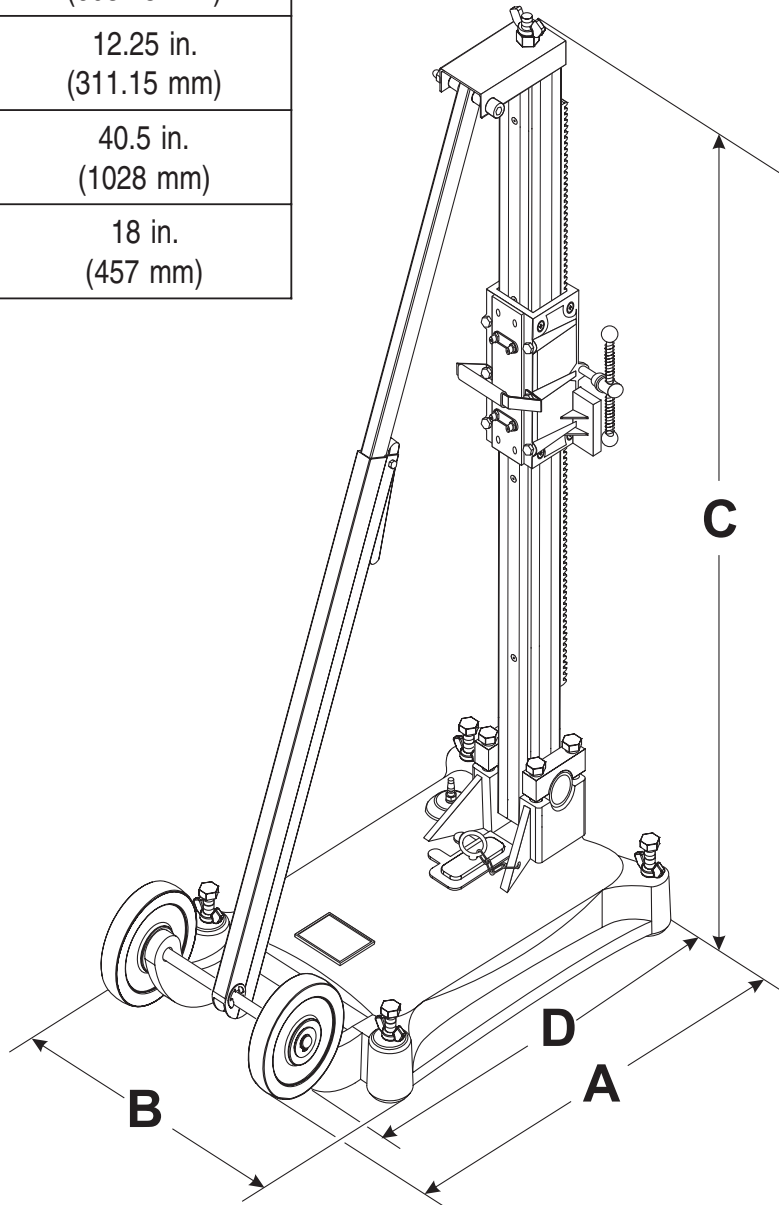

Figure 2 CDM2CSA Drill Stand

DM15A9C/CDM2CSA— DRILL RIG COMPONENTS

Figure 3 illustrates the basic components of the MQ CDM2CSA Drill Rig. Shown below is brief explanation of each component.

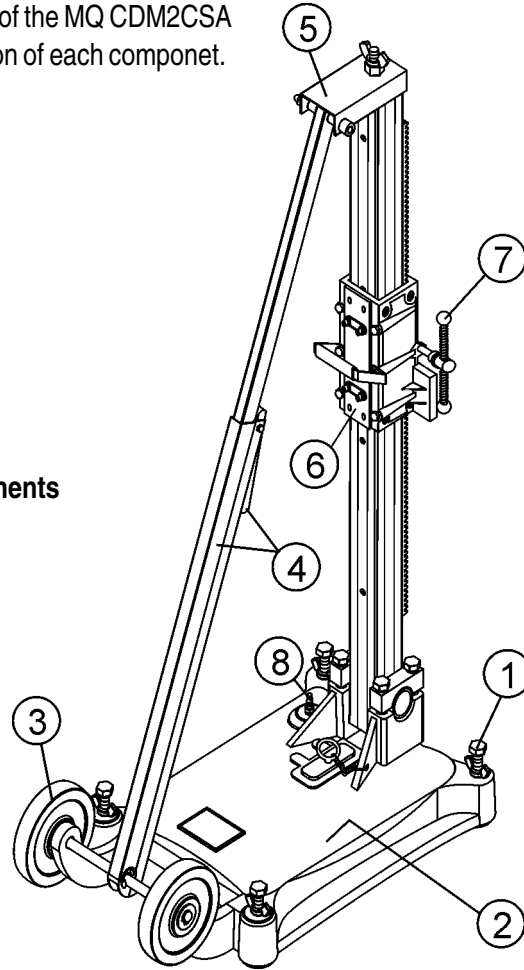

Figure 3. CDM2CSA Drill Rig Components

1. **Leveling Screws** – Use these screws (4) to level the drill rig.
2. **Base** – Supports the column rack and associated components.
3. **Wheels** – 2 rear wheels have been provided for ease of maneuverability. To move the drill rig grab hold of the handle on the cradle assembly and tilt the unit slightly, then pull or push.
4. **Angle Rod** – This is an adjustable rod. To shorten or lengthen, squeeze and hold the rod release trigger. Set angle rod to desired position, release trigger.
5. **Adjustment Rod Cover Lock** – This cover must be secured to the column mast at all times when the unit is in use. **NEVER!** use the drill rig with this cover removed. The possibility exists of the column falling.
6. **Cradle Assembly** – This unit is responsible for the raising and lowering of the core drill and is placed onto the column rack. There is a tensioner knob located on the side of the cradle that determines the ease at which the cradle will move up and down along the rack.
Adjust the tension so that the cradle moves smoothly and freely. Before placing core drill onto cradle, always make sure the tension knob is securely tightened. This will prevent the core drill from falling.
7. **Cradle Raise/Lower Handle** – Use this handle to raise or lower the core drill.
8. **Vacuum Hose Fitting** – Connect the output end of the vacuum pump hose to this fitting.

DM15A9C/CDM2CSA — CORE DRILL MOTOR COMPONENTS

Figure 4 illustrates the basic components of the MQ DM15A9C Drill Rig. Shown below is brief explanation of each component.

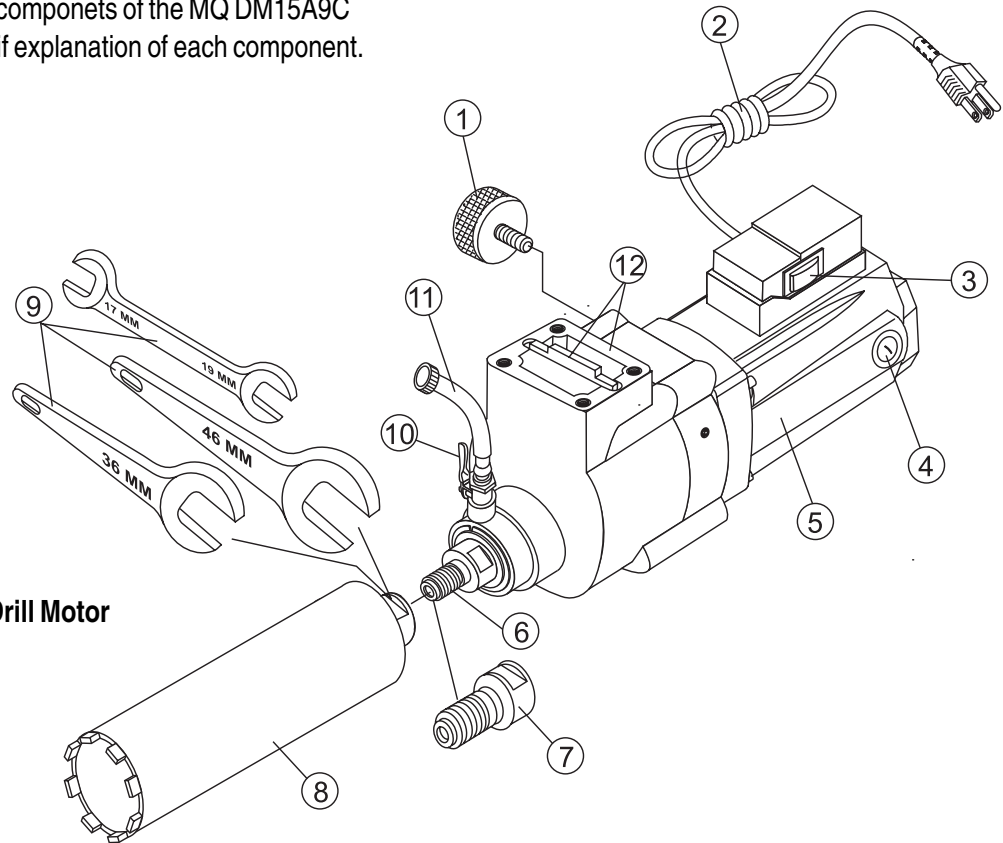

Figure 4. DM15A9C Core Drill Motor

1. **Speed Adjustment Knob** – Use this knob to adjust the speed of the electric motor. Turn knob counter-clockwise to loosen. Push knob toward shaft end to decrease motor speed. Pull knob back towards ON/OFF switch to increase motor speed. Once knob is in desired position, lock in place by turning fully clockwise.
2. **AC Power Cord** – Plug this 16 ft. (4.87 meters) power cord into a 115 VAC grounded type receptacle. **NEVER** remove the ground pin from the plug. This will defeat the ground circuit and greatly increase the possibility of electrical shock.
3. **ON/OFF Rocker Switch**– Press this rocker switch to start and stop the electric motor.
4. **Electric Motor Brush Covers (2)** – Insert tip of a flat blade screwdriver into slot on brush cover, turn counter-clockwise and remove cover to gain access to brushes.
5. **Drill Body** –The electric motor and associated components are contained inside the drill body.
6. **Main Shaft** – Attach core drill bit to this shaft. Main shaft is 1-1/4"-7 (7 threads per inch) male. Shaft size fits most core bits from 1-1/2" through 9" diameter.
7. **Adapter Reducer** – Multiquip offers (option) a reducing adapter, 1-1/4"-7 female to 5/8"-11 male for bits smaller than 1-1/2" diameter.
8. **Core Drill Bit**– Place bit onto main shaft and tighten securely. Contact MQ sales department for the core drill bit that best fits your application.
9. **Wrenches** – 3 wrenches are supplied with the DM15A9C electric core drill motor. These wrenches (17, 19, 36 and 46 mm) are used to install and remove the core drill bits.
10. **Water Shut-off Valve** – Turn this valve downward to let water flow and up to stop.
11. **Water Tube/Adapter** – Connect this tube/adaptor to a water source, typically a garden hose.
12. **Core Drill Base/Woodruff key** – Attach this base to the cradle assembly located on the column rack. Align woodruff key with slot on base of cradle.

Before Starting:

!
CAUTION - Read Manual

Before attempting to operate this core drill, and to avoid serious injury to personnel, always read and understand operation manual. Failure to read and understand operation manual could result in serious harm or even death!

! WARNING

To avoid injury, you **MUST** read and understand operator's manual before using this machine.

This machine to be operated by qualified personnel only. Ask for training as needed.

!
Warning - Toxic Fumes

NEVER operate the core drill in a confined or enclosed area structure that does not provide ample **free flow of air**.

3. Place the drilling rig in an upright position on a firm flat surface (Figure 5).

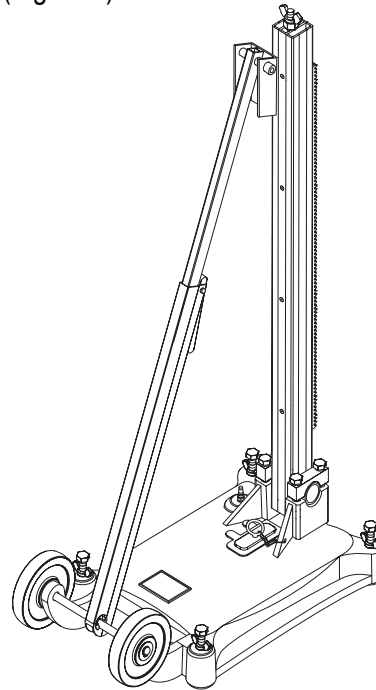

Figure 5. Dril Rig (upright Position)

!
DANGER - Flammable/Combustible Materials

NEVER operate the core drill in or around flammable materials. The core drill emits sparks. If contact is made between the sparks and the flammable material, the possibility exists of fire or explosion causing damage to the equipment and severe bodily harm even death!

CDM-2CSA Drill Rig Assembly Instructions

Assemble the the CDM-2CSA Drilling Rig as follows:

1. Open the shipping container and place all associated components on a suitable workbench that is clean and free of debris.
2. Make sure all assembly components are accounted for by checking them against items listed in Table 5. If any components are missing, contact your nearest MQ dealer.

Table 5. Assembly Parts List		
Item	Description	QTY.
1	17/19 mm wrench	1
2	36 mm wrench	1
3	46 mm wrench	1
4	1-1/2 x13 mm screw	4
5	5/8-inch lock washer	4

4. Remove the wingnut located at the top of the column as shown in Figure 6.

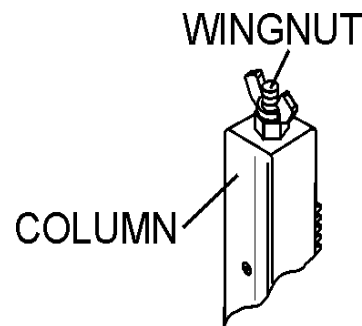

Figure 6. Wingnut Removal

5. Locate the cradle assembly (Figure 7) and place it directly over the column. Make sure the cradle handle is located on the right side of the column if you are standing at the back (wheels) of the drilling rig. It may be necessary to loosen the cradle tension knob slightly to allow the cradle to slip onto the column rack.

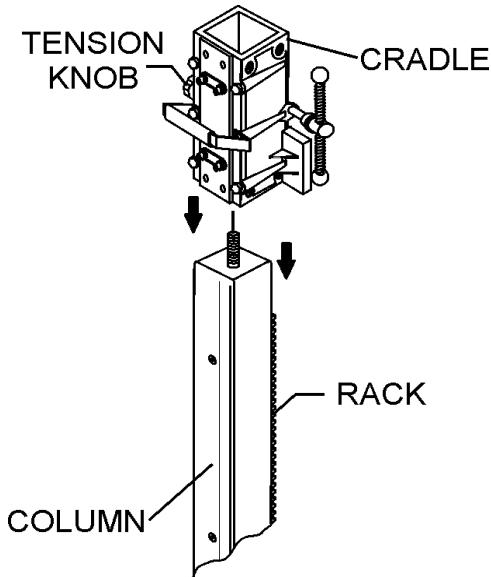

Figure 7. Cradle Assembly

6. Once the cradle assembly makes contact with the rack, turn the cradle raise/lower handle (Figure 8) clockwise so that the cradle moves in a downward position. Continue turning handle until the desired position has been reached.

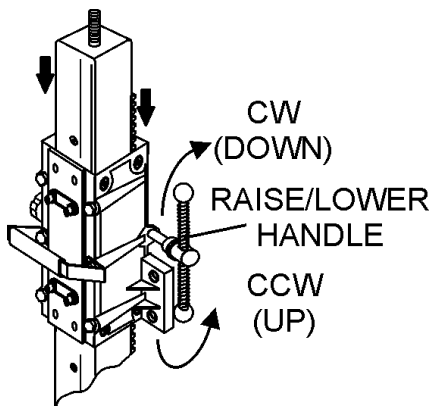

Figure 8. Cradle Raise/Lower Handle

7. Once the cradle has been mounted onto the column rack, align the top plate (Figure 9) on the adjustment bar with the stud on the top of the column. It may be necessary to squeeze the trigger release (Figure 8) mechanism on the adjustment bar to raise or lower the adjustment bar.

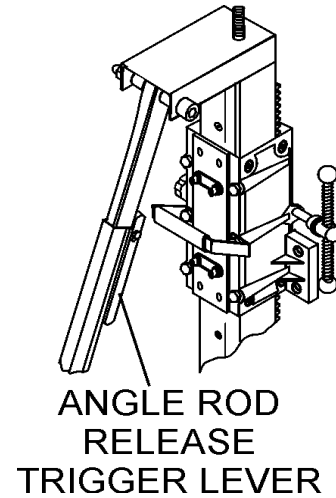

Figure 9. Adjustment Bar Placement

8. Re-install the wingnut that was removed in step 4.

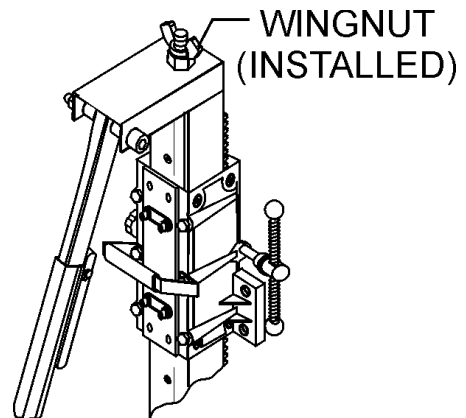

Figure 10. Securing the Adjustment Bar

9. The unit is now ready to be secured to the work surface.

Securing the Drill Rig Assembly

Secure the Drilling Rig as follows:

! DANGER - Drill Rig Tipping

DO NOT attempt to use this unit until it has been securely anchored to a suitable surface. The possibility exists of severe bodily harm and damage to the equipment if the core drill bit becomes stuck or binds thus causing the unit to tip over.

This drilling rig can be secured by various methods. Please read the next few paragraphs to determine which method best suits your application.

Method 1 incorporates the use of a **vacuum pump**. The vacuum pump will provide the necessary suction when used in conjunction with the supplied rubber gasket seal.

1. Lay drilling rig in the down position so that access to base plate is possible.
2. Make sure rubber gasket seal is placed evenly into base plate groove as shown in Figure 11. For best results apply a little water to the seal. Applying water to the seal will make a tighter suction when the vacuum pump is turned on. If seal is worn or damaged, replace with a new one.

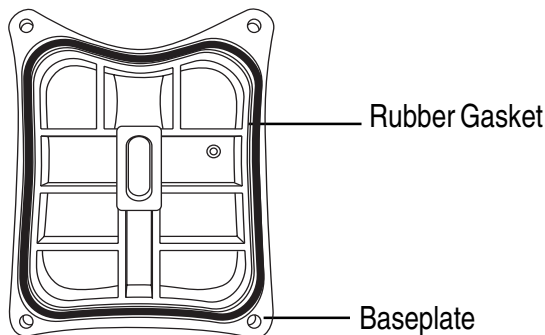

Figure 11. Baseplate Rubber Gasket (Bottom View)

3. Return the drilling rig to its upright position.
4. Insert supplied vacuum adapter pad into slot on base of drilling rig as shown in Figure 12.

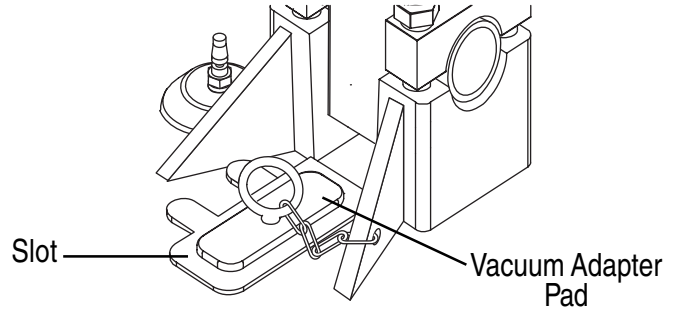

Figure 12. Vacuum Adapter Pad Insertion

5. On the vacuum pump there is a vacuum hose (Figure 13). Connect the free end of the vacuum hose to vacuum line hose fitting located on the baseplate.

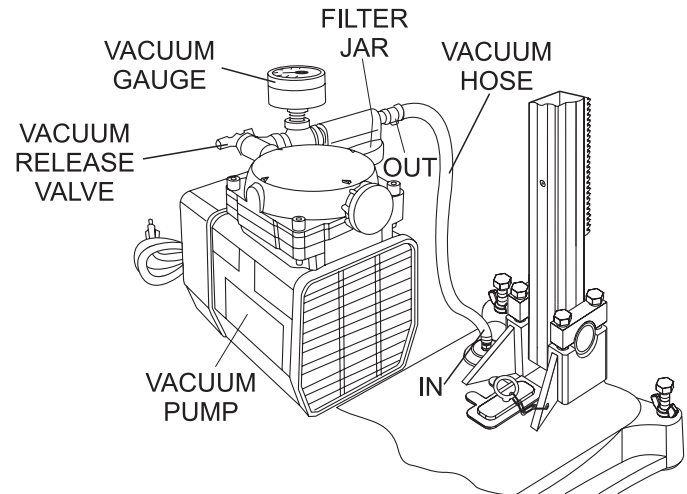
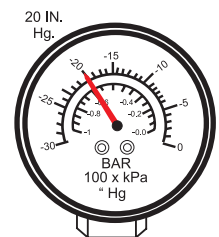

Figure 13. Vacuum Pump

6. Plug the power cord on the vacuum pump into a 120 VAC, 60 Hz power source. The unit will turn on immediately, there is no OFF/ON switch.
7. Step on the base until it lowers and adheres to the work surface.
8. Tighten the leveling screws (4) only enough to eliminate rocking. Over-tightening can lift the gasket off the ground and release the vacuum.

! CAUTION - VACUUM GAUGE READING

DO NOT attempt to use this unit until the vacuum gauge reads a minimum of 20 in. Hg. The possibility exists of the gasket vacuum seal being broken and the unit tipping over.



Method 2 incorporates drilling a hole 1/2-inch in diameter into the drill rig support surface (wall or floor), and inserting an expansion type anchor.

- Using a masonry bit, drill a hole approximately 1/2-inch in diameter. When drilling the hole make sure it is approximately 200 mm away from center. See Figure 14. Make the depth of the hole so that the desired anchor is flush or just beneath the surface

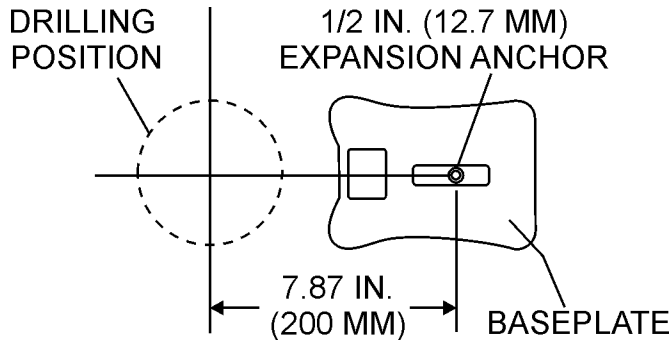
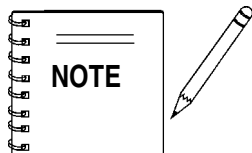

Figure 14. Baseplate Drilling Alignment

- Insert the anchor (Figure 15) into the 1/2-inch hole that was drilled into the surface. It may be necessary to slightly tap the anchor into the hole. For best results, a tight fit of the anchor is required. This will keep the anchor from pulling out.
- Align the slot on the baseplate with the 1/2-inch hole on the surface.
- Insert a 1/2-inch X 4.75 (not to exceed 4.75 inches) bolt with a 1/2-inch washer through the baseplate slot and screw it into the anchor.
- Fully tighten the 1/2-inch bolt to secure the drill rig. If the drill rig does not tighten down all the way, it may be necessary to use additional 1/2-inch flat washers to fully secure the drill rig.



Different size wrenches may be required depending on type of core bit.

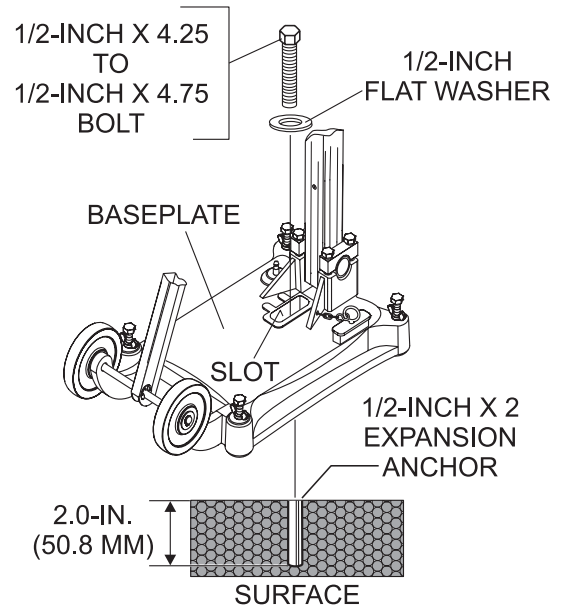

Figure 15. Baseplate (Expansion Anchor)

Attaching the Core Bit to the Core Drill

- Place the core bit and core drill motor on a suitable work-bench or area that is free of clutter dirt and debris. **If desired the core drill bit can be attached to the motor after the motor has been secured to the drill rig,**
- Before installing the core bit, make sure that the power cord of the core drill is unplugged from the AC wall receptacle. **NEVER** install the core bit on core drill that has power applied to it.
- Screw the core bit onto the main shaft of the core drill by turning it clockwise by hand until tight (Figure 16).
- Using the supplied wrenches continue to tighten the core bit. When using the wrenches, apply pressure in the opposite direction to fully tighten.

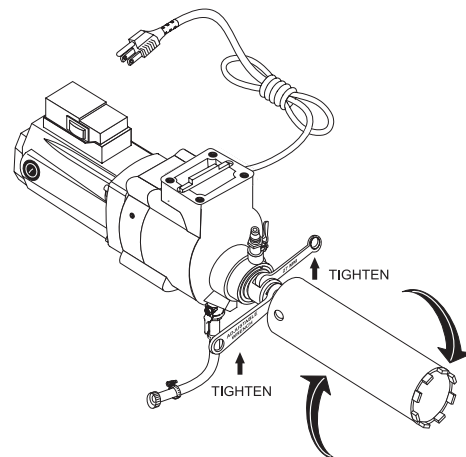

Figure 16. Attaching the Core Bit to the Core Drill

Attaching the Core Drill Motor to the Cradle

1. There may be an aluminum adapter plate (Figure 17) attached to the core drill motor. Remove this plate using a 6 mm allen wrench before attempting to secure the drill motor to the cradle. This adapter plate is intended to be used on other MQ drill rig stands.
2. The core drill motor can be secured to the cradle (Figure 17) by means of 4 retaining screws and lock washers. Use a 6 MM allen wrench to tighten the screws. Make sure to align the woodruff key on the drill base with the slot on the cradle.
3. The core drill motor is very heavy and with the added weight of the drill bit makes it even heavier. When mounting the drill motor to the cradle assembly, **always use 2 people.**

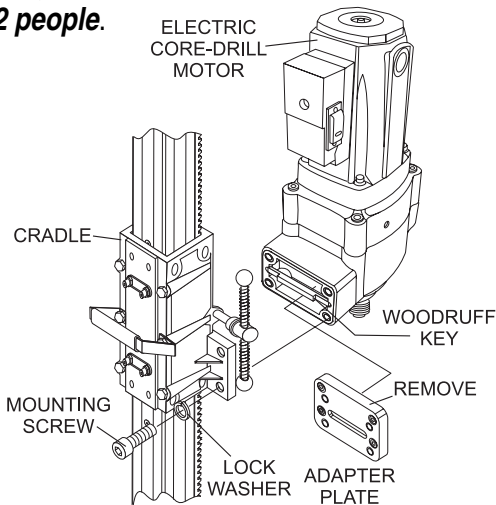

Figure 17. Attaching the Core Drill Motor to the Cradle

Connecting Water to the Core Drill

1. Attach the supplied water hose and garden hose fitting to the core drill as shown in Figure 18. Be sure to place worm-clamps on each end of the hose to prevent leaking.

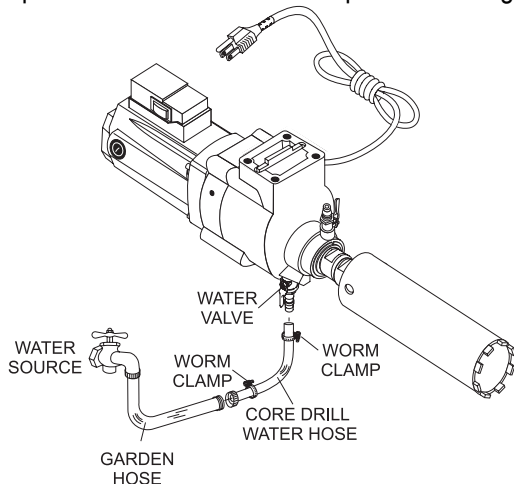

Figure 18. Connecting the Water

Applying Power to the Core Drill

1. This core drill requires 115 VAC, 60 Hz power. Applying power to the drill that is not specified will cause severe damage to the core drill. Always read serial plate tag before applying power to the core drill.
2. The power plug on this core drill is a 3-prong grounded type plug. **ALWAYS** connect this plug to a 3-prong grounded receptacle. **NEVER** plug this device into a 2-prong type receptacle. This will defeat the ground circuit. The use of a 3-prong to 2-prong adapter is strictly prohibited.

Warning - Accidental Starting

To avoid accidental starting, **ALWAYS** keep fingers away from the power **OFF/ON** switch when applying power.

3. Connect the core drill's AC power cord to a 115 VAC wall receptacle (Figure 19) that is protected by a 20 amp circuit breaker. For best results connect the power cord to a GFCI receptacle.

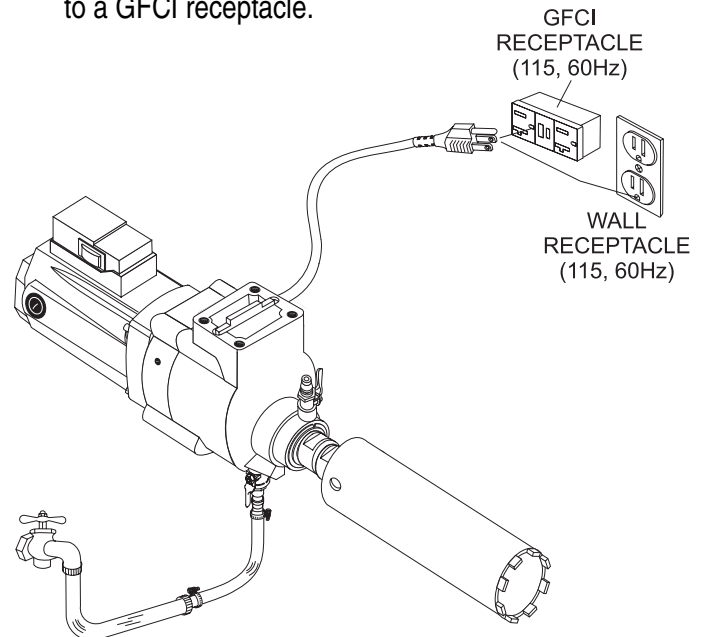

Figure 19. Connecting the Power

Operation

1. Place the valve on the water source to the **ON** position, and then turn the water valve on the core drill (Figure 20) to the **ON** position (down). Verify that water is flowing smoothly and evenly. Turn the valve clockwise to increase water flow and counterclockwise to decrease water flow.

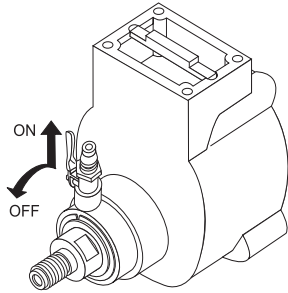
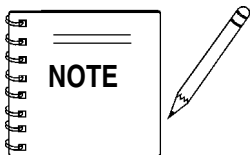

Figure 20. Water Valve (ON Position)

2. If water is not flowing, check all connections and correct the problem. Water should be flowing at a rate of one or two gallons per minutes.
3. Turn the core drill power **ON/OFF** switch to the **ON** position. The drill bit should begin to rotate at the desired rpm setting.
4. Hold the cradle handle, then slightly loosen the cradle lock knob and slowly rotate clockwise the raise/lower handle to lower the bit into the work surface (Figures 21 and 22), applying steady even pressure.
5. Water flow is adequate when the water and cuttings are flushed in a circular pattern about 1/2-inch (12.7 mm) around the bit.
6. To help reduce bit "walking", always use a light pressure to start the hole and wait for the bit to penetrate the work surface completely before increasing the pressure.
7. When the cut is complete, keep the drill motor **ON** and rotate the raise lower handle counterclockwise to remove the bit.



ALWAYS be on the lookout for exposed wiring or buried electrical connections when drilling.

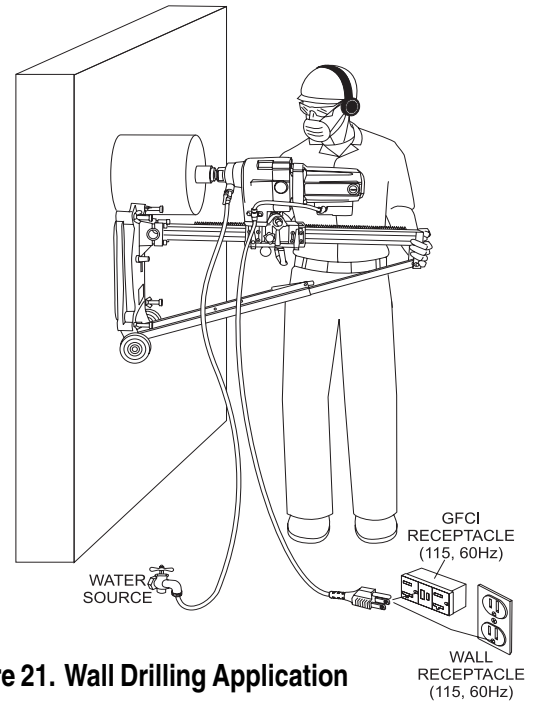
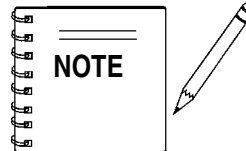

Figure 21. Wall Drilling Application



When removing the bit from the cut, always keep the power on. This will prevent bit from being stuck as the bit is being raised. **ALWAYS** drill with uniform pressure and keep the bit straight. When drilling through steel rebar, reduce the pressure to avoid overloading the motor.

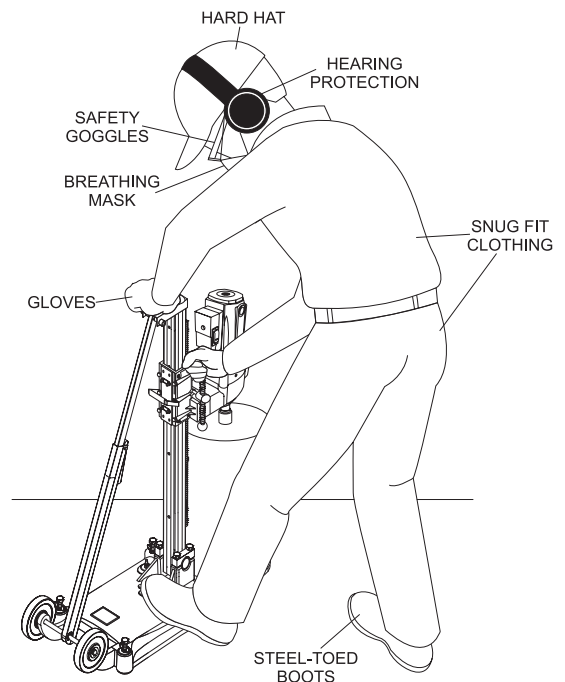

Figure 22. Floor Drilling Application



Danger - Drill Bit Cores

When drilling from high places, cores can often drop from the drill bit. When drilling in high places make sure work personnel and equipment below are clear of drilling area. The possibility exists of a core falling on equipment causing damage to the equipment or severe bodily harm even death! to work personnel.

Shutdown

1. Place the power **ON/OFF** switch on the core drill motor in the **OFF** position and unplug the power cord from the wall receptacle or power source.
2. Allow a sufficient amount of time for the core drill bit to cool before attempting to remove it from the core drill motor.
3. Using the wrenches as illustrated in Figure 4, remove the core drill bit from the drill.
4. If desired remove the core drill motor from the cradle. Tighten the cradle lock knob to prevent the cradle from falling off the column rack.
5. If a vacuum pump was used to secure the unit, unplug its power cord from the wall receptacle or power source. Open the the vacuum release valve to release the vacuum pressure.
5. If a an expandable anchor was used to secure the unit, remove the securing bolt so that the unit can be moved.
6. Once the core drill has been cleaned, place the core drill into its carrying case along with all associated hardware. Be sure to wrap the power cord neatly into the carrying case. This will extend the life of the cord.
7. Clean the drill bit with a mild cleaning solution, removing dirt and foreign matter.
6. Store the drill rig and core drill motor out of the reach of children, in a location that is moisture free.

Maintenance

Clutch Adjustment

1. The DM15A9C electric motor is basically maintenance free. However, it may become necessary at some time to adjust the clutch.
2. Using a 5 mm allen wrench, remove the hex plug as shown in Figure 23A to gain access to the clutch adjustment hole.
3. Insert a small blade screwdriver (Figure 23B) into the access hole so that it prevents the motor shaft from rotating fully.
4. Using the supplied wrenches (Figure 23B) rotate the motor shaft counterclockwise about 15 degrees. The screwdriver will keep the shaft from rotating fully.

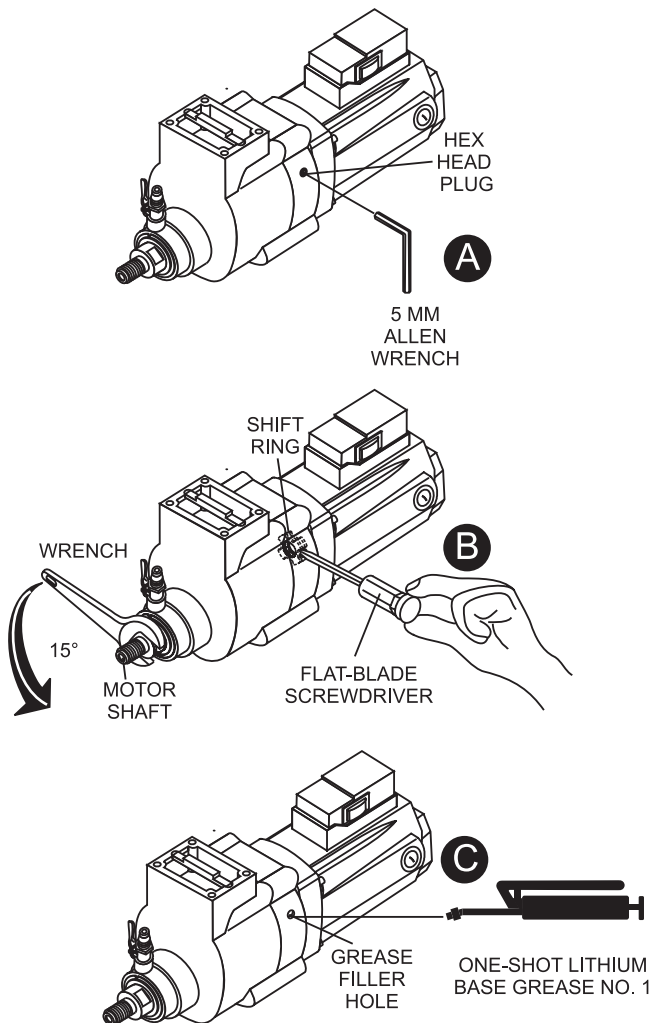

Figure 23. Clutch Adjustment/Lubrication

Lubrication

1. Using a 5 mm allen wrench, remove the hex plug as shown in Figure 23A.
2. Visually inspect to see if grease is present. It may be necessary to insert a small blade screw driver or similar device into the filler hole to determine if the grease level is low.
3. If the grease level is low, apply 1 shot of lithium base grease, grade N0.1. **DO NOT** over fill. See Figure 23C.
4. Reinstall hex plug and tighten securely.

Carbon Brushes

1. Using a flatblade screw driver unscrew the plastic cap as shown in Figure 24 to gain access to the carbon brushes. There is a plastic cap on each side of the drill motor.
2. Periodically check the carbon brushes for signs of wear. Typically replace brushes when the wear height is down to 0.2 inches (5mm). Using defective or worn brushes could cause motor failure.
3. Replace worn or defective brushes with new ones. Keep them clean so that they can slide freely within the brush holder. Use only MQ recommended parts.

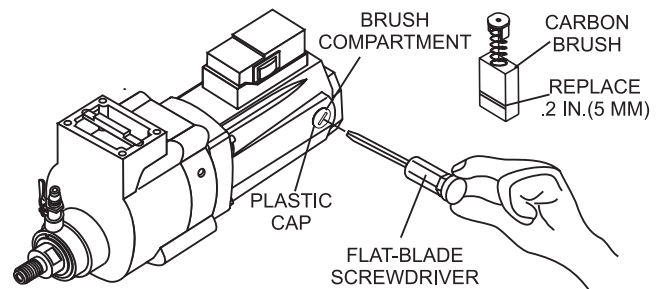

Figure 24. Carbon Brush Replacement

Cleaning and Storage

1. Clean drill motor and drill rig with a mild soap and a damp cloth removing dirt and foreign debris that might have accumulated on the equipment during operation. **DO NOT** use gasoline or harmful chemical as a cleaning agent some of these chemicals are harmful to plastics.
2. Remove any dirt and dust from the motor vents
3. Store equipment in a clean dry location that is moisture free out of the reach of children and unauthorized personnel.

TABLE 6. CORE DRILL TROUBLESHOOTING

SYMPTOM	POSSIBLE PROBLEM	SOLUTION
Bit is stuck.	Steel bar or stone, etc. is caught between core and bit?.	Immediate turn SWITCH OFF.
	Excessive wear, bit tip has become flush with shank?	Try to rotate BIT in both directions using spanner to lift it out.
	Glazed bit?	Replace BIT.
Drilling is slow in normal operation.	Waste water is contaminated with steel chip, DRILL is cutting rebar?	Immediately check the waster water. Adjust the pressure on so as not to overload MOTOR.
	Bit is worn?	Immediately check BIT for abrasion. Replace BIT.
	Segments missing?	Immediately check BIT for abrasion. Dress BIT.
	Chips deposited on BIT surfac?.	Immediately check BIT for abrasion. Increase water feed pressure. Dress or Brush BIT with a wire.
	Steel chips are scorched on BIT surface?	Immediately check BIT for abrasion. Remove steel chips.

CORE DRILL — EXPLANATION OF CODE IN REMARKS COLUMN

The following section explains the different symbols and remarks used in the Parts section of this manual. Use the help numbers found on the back page of the manual if there are any questions.

The contents and part numbers listed in the parts section are subject to change **without notice**. Multiquip does not guarantee the availability of the parts listed.

Sample Parts List:

NO.	PART NO.	PART NAME	QTY.	REMARKS
1	12345	BOLT	1	INCLUDES ITEMS W/*
2*		WASHER, 1/4 IN.		NOT SOLD SEPARATELY
2*	12347	WASHER, 3/8 IN.	1	MQ-45T ONLY
3	12348	HOSE	A/R ..	MAKE LOCALLY
4	12349	BEARING	1	S/N 2345B AND ABOVE

NO. Column

Unique Symbols - All items with same unique symbol (*, #, +, %, or >) in the number column belong to the same assembly or kit, which is indicated by a note in the “Remarks” column.

Duplicate Item Numbers - Duplicate numbers indicate multiple part numbers are in effect for the same general item, such as different size saw blade guards in use or a part that has been updated on newer versions of the same machine.

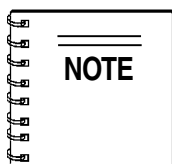

When ordering a part that has more than one item number listed, check the remarks column for help in determining the proper part to order.

PART NO. Column

Numbers Used - Part numbers can be indicated by a number, a blank entry, or TBD.

TBD (To Be Determined) is generally used to show a part that has not been assigned a formal part number at time of publication.

A blank entry generally indicates that the item is not sold separately or is not sold by Multiquip. Other entries will be clarified in the “Remarks” Column.

QTY. Column

Numbers Used - Item quantity can be indicated by a number, a blank entry, or A/R.

A/R (As Required) is generally used for hoses or other parts that are sold in bulk and cut to length.

A blank entry generally indicates that the item is not sold separately. Other entries will be clarified in the “Remarks” Column.

REMARKS Column

Some of the most common notes found in the “Remarks” Column are listed below. Other additional notes needed to describe the item can also be shown.

Assembly/Kit - All items on the parts list with the same unique symbol will be included when this item is purchased.

Indicated by:

“INCLUDES ITEMS W/(unique symbol)”

Serial Number Break - Used to list an effective serial number range where a particular part is used.

Indicated by:

“S/N XXXXX AND BELOW”

“S/N XXXX AND ABOVE”

“S/N XXXX TO S/N XXX”

Specific Model Number Use - Indicates that the part is used only with the specific model number or model number variant listed. It can also be used to show a part is NOT used on a specific model or model number variant.

Indicated by:

“XXXXX ONLY”

“NOT USED ON XXXX”

“Make/Obtain Locally” - Indicates that the part can be purchased at any hardware shop or made out of available items. Examples include battery cables, shims, and certain washers and nuts.

“Not Sold Separately” - Indicates that an item cannot be purchased as a separate item and is either part of an assembly/kit that can be purchased, or is not available for sale through Multiquip.

DM15A9C/CDM2CSA— SUGGESTED SPARE PARTS

DM15A9C/CDM2CSA Core Drill and Drilling Rig

1 to 5 Units

Qty.....	P/N	Description
2	CD290057	CARBON BRUSH
2	CD290062	POWER CORD
2	CD290065	POWER SWITCH

DM15A9C/CDM2CSA—NAMEPLATE AND DECALS

NAMEPLATE AND DECALS

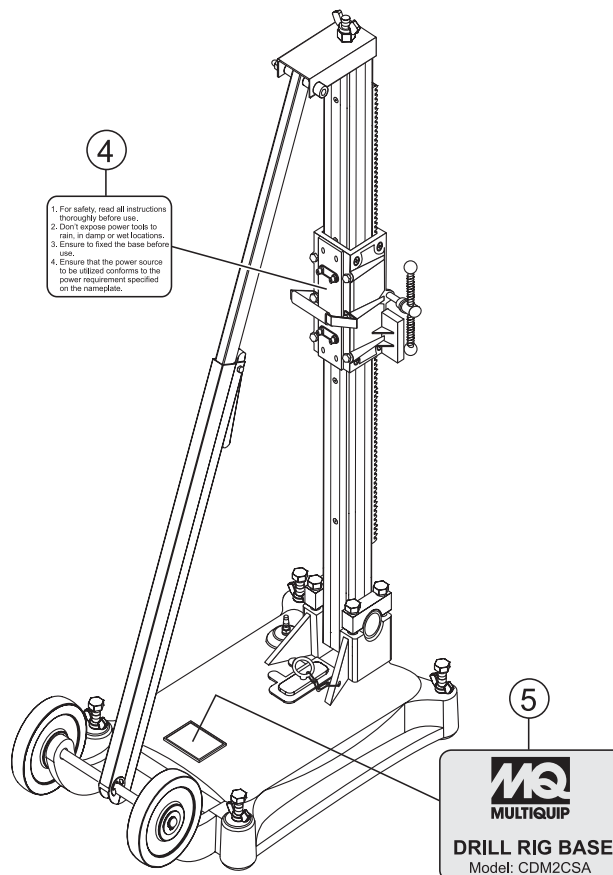
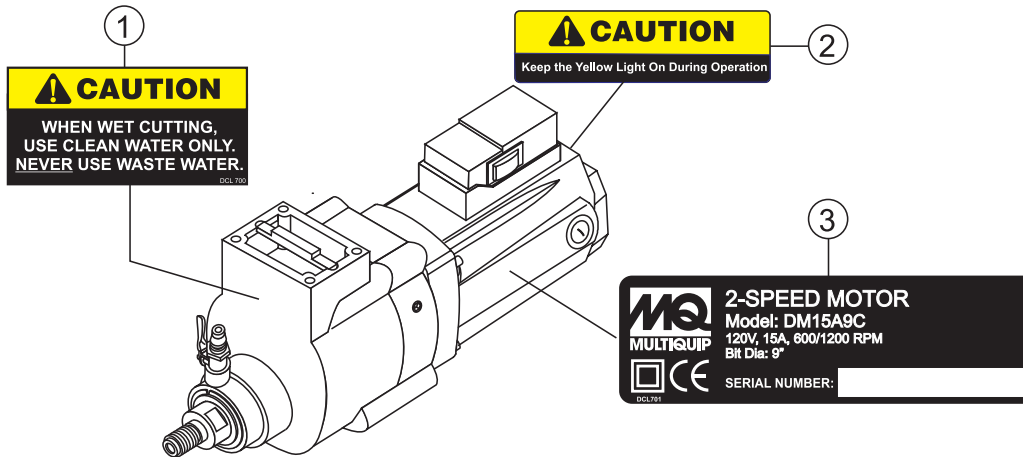

DM15A9C/CDM2CSA—NAMEPLATE AND DECALS

NAMEPLATE AND DECALS

<u>NO.</u>	<u>PART NO.</u>	<u>PART NAME</u>	<u>QTY.</u>	<u>REMARKS</u>
1	DCL700	DECAL: CAUTION CLEAN WATER	1	
2	CDL001	DECAL: CAUTION, OPERATION LIGHT	1	
3	DCL704	DECAL: MODEL INFORMATION	1	
4	CDL002	DECAL: INSTRUCTIONS	1	
5	CDB001	DECAL: MQ LOGO	1	

DM15A9C — ELECTRIC MOTOR ASSEMBLY

ELECTRIC MOTOR ASSY.

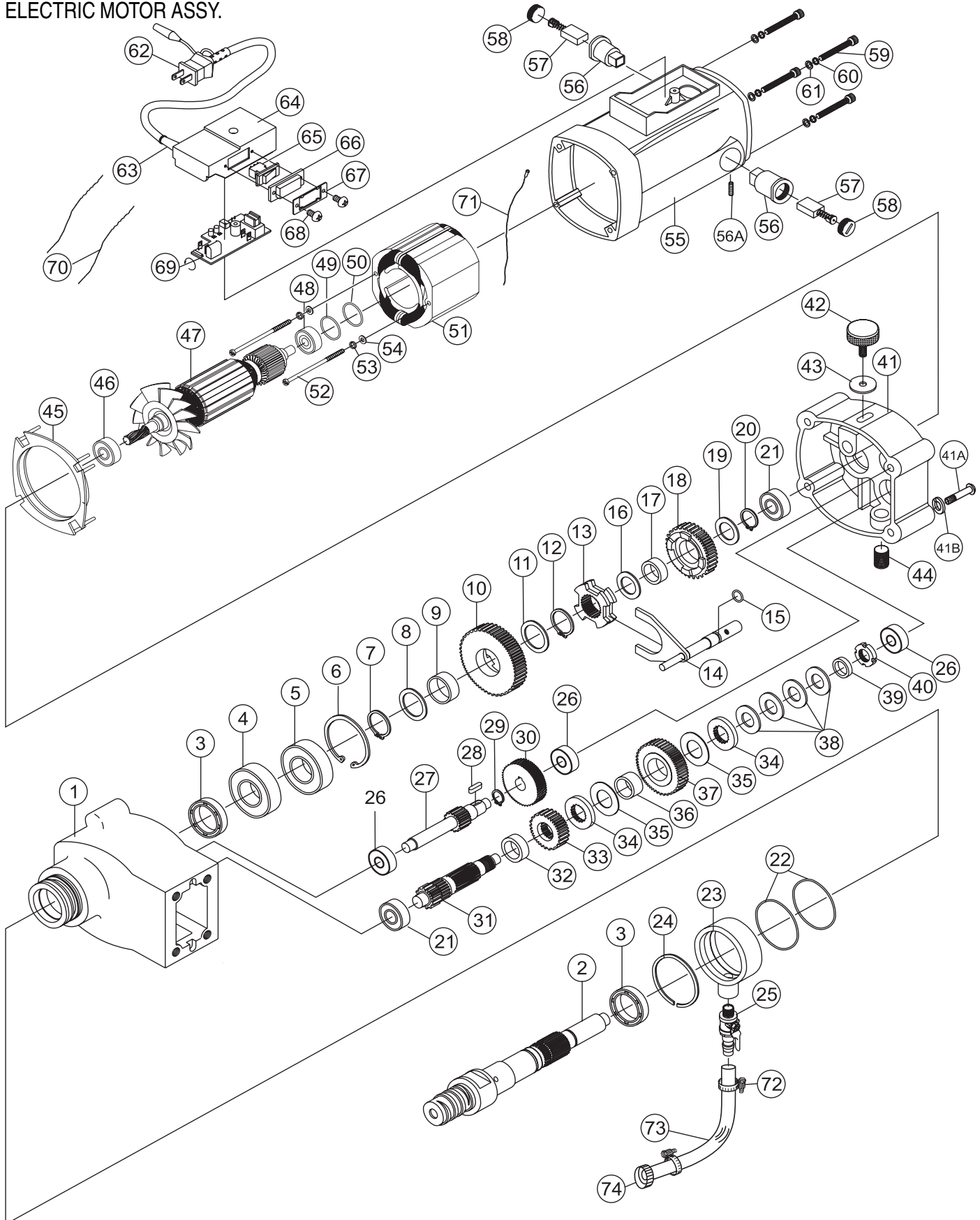

DM15A9C — ELECTRIC MOTOR ASSEMBLY

ELECTRIC MOTOR ASSY.

<u>NO.</u>	<u>PART NO.</u>	<u>PART NAME</u>	<u>QTY.</u>	<u>REMARKS</u>
1	CD290001	GEAR CASE	1	
2	CD290002	MAIN SHAFT	1	
3	CD290003	SEAL, 34X48X8 MM	1	
4	CD290004	BEARING, 6206LLU	1	
5	CD290005	BEARING, 6206ZZ	1	
6	CD290006	SNAP RING, R62	1	
7	CD290007	SNAP RING, S30	1	
8	CD2900081	METAL COLLAR	1	
9	CD290009	METAL COLLAR	1	
10	CD290010	FIRST GEAR	1	
11	CD290011	METAL COLLAR	1	
12	CD290012	SNAP RING, S29	1	
13	CD290013	SHIFT RING	1	
14	CD290014	SHIFT LEVER	1	
15	CD290015	O-RING, 11X2.0 MM	1	
16	CD290016	METAL COLLAR	1	
17	CD290017	METAL	1	
18	CD290018	SECOND GEAR	1	
19	CD290019	METAL COLLAR	1	
20	CD290020	SNAP RING, S22	1	
21	CD290021	BEARING, 6202ZZ	1	
22	CD290022	O-RING, 60X2.0 MM	1	
23	CD290023	WATER SUPPLY COVER	1	
24	CD290024	SNAP RING, IS63	1	
25	CD290025	WATER COCK	1	
26	CD290026	BEARING, 6201ZZ	1	
27	CD290027	FIRST PINION	1	
28	CD290028	WOODRUFF KEY, 5X5X12 MM	1	
29	CD290029	SNAP RING, S15	1	
30	CD290030	THIRD GEAR	1	
31	CD290031	SECOND GEAR	1	
32	CD290032	SPACER	1	
33	CD290033	FORTH GEAR	1	
34	CD290034	PLATE	2	
35	CD290035	FRICTION PLATE	2	
36	CD290036	METAL	1	
37	CD290037	FIFTH GEAR	1	
38	CD290038	DISK SPRING, 35.2X18.3X2.0 MM	4	
39	CD290039	METAL COLLAR	1	
40	CD290040	FINE U-NUT	1	
41	CD290041	DIAPHRAGM	1	
41A	CD2900411	DIAPHRAGM SCREW, M8 60	4	
41B	CD2900412	DIAPHRAGM LOCK WASHER, M8	4	
42	CD290042	SPEED CHANGE KNOB	1	
43	CD290043	RUBBER WASHER	1	
44	CD290044	PLUG, 1/8"	1	
45	CD290045	BAFFLE	1	
46	CD290046	BEARING, 6201LLU	1	
47	CD290047	ARMATURE	1	
48	CD290048	BEARING, 6200ZZ	1	
49	CD290049	FILING RING, 6200	1	
50	CD290050	O-RING	1	
51	CD290051	FIELD	1	
52	CD290052	FIELD SCREW, M5X85 MM	2	

DM15A9C — ELECTRIC MOTOR ASSEMBLY

ELECTRIC MOTOR ASSY.

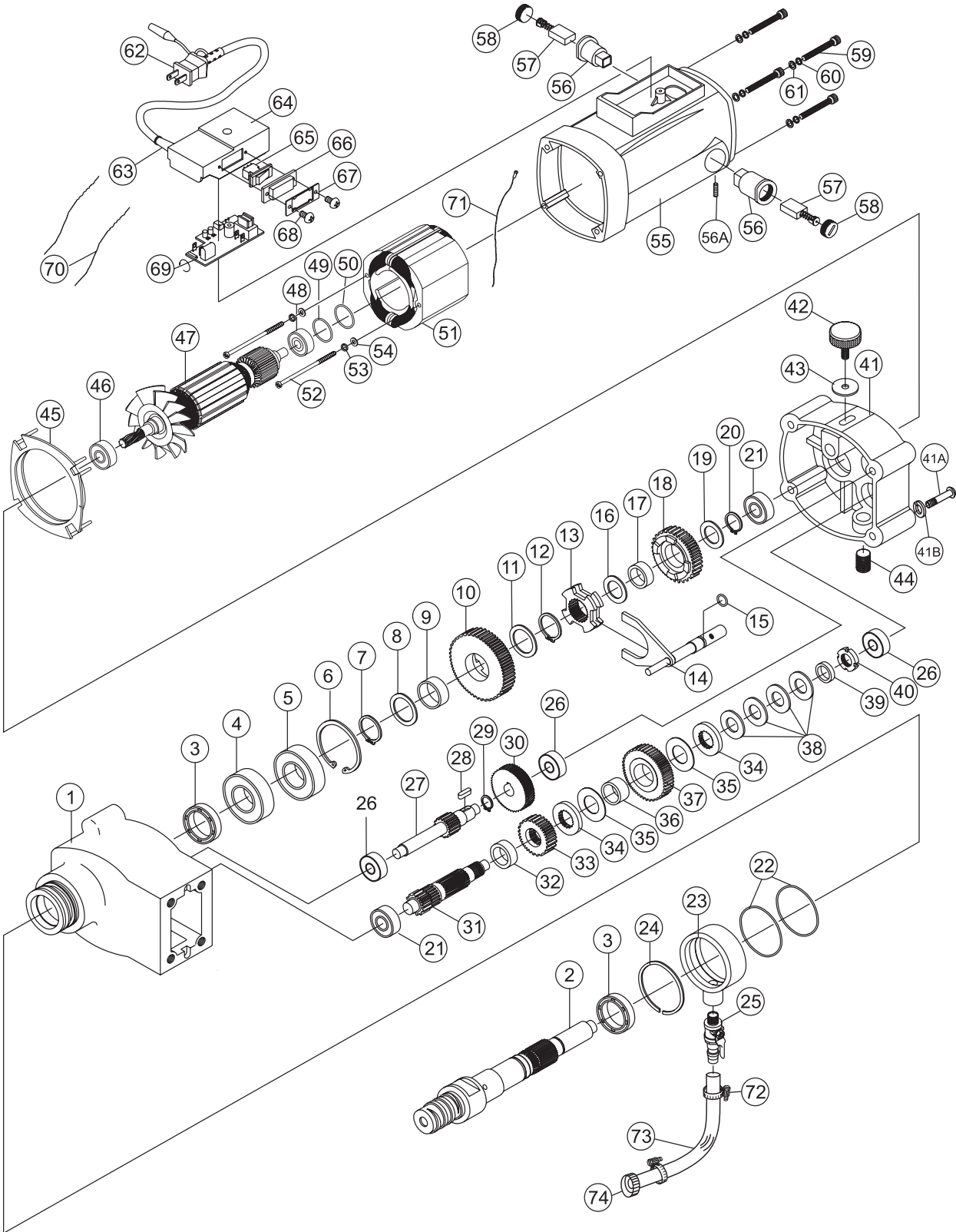

DM15A9C — ELECTRIC MOTOR ASSEMBLY

ELECTRIC MOTOR ASSY.

<u>NO.</u>	<u>PART NO.</u>	<u>PART NAME</u>	<u>QTY.</u>	<u>REMARKS</u>
53	CD290053	WASHER, LOCK 5 MM	2	
54	CD290054	WASHER, FLAT 5 MM	2	
55	CD290055	MOTOR HOUSE	1	
56	CD290056	BRUSH TUBE	2	
56A	CD5900561	BRUSH TUBE SCREW, M5X10 MM	2	
57	CD290057	CARBON BRUSH	2	
58	CD290058	BRUSH COVER	2	
59	CD290059	SCREW, M6X45 MM	4	
60	CD290060	WASHER, LOCK 6MM	4	
61	CD290061	WASHER, FLAT 6MM	4	
62	CD290062	ELECTRIC CABLE	1	
63	CD290063	RUBBER TUB	1	
64	CD290064	SWITCH BOX	1	
65	CD290065	SWITCH	1	
66	CD290066	SWITCH COVER	1	
67	CD290067	SWITCH PLATE	1	
68	CD290068	SWITCH SCREW, 1/8 X 1/4"	2	
69	CD290069	LED INDICATOR	1	
70	CD290070	CABLE	1	
71	CD290071	EARTH CABLE	1	
72	CD101569	HOSE CLAMP	2	
73	CD101570	PLASTIC WATER HOSE, 4-INCH	1	
74	CD101571	FITTING, BRASS BARB 3/4 X 3/8"	1	

CDM2CSA — DRILLING RIG ASSEMBLY

DRILLING RIG ASSY.

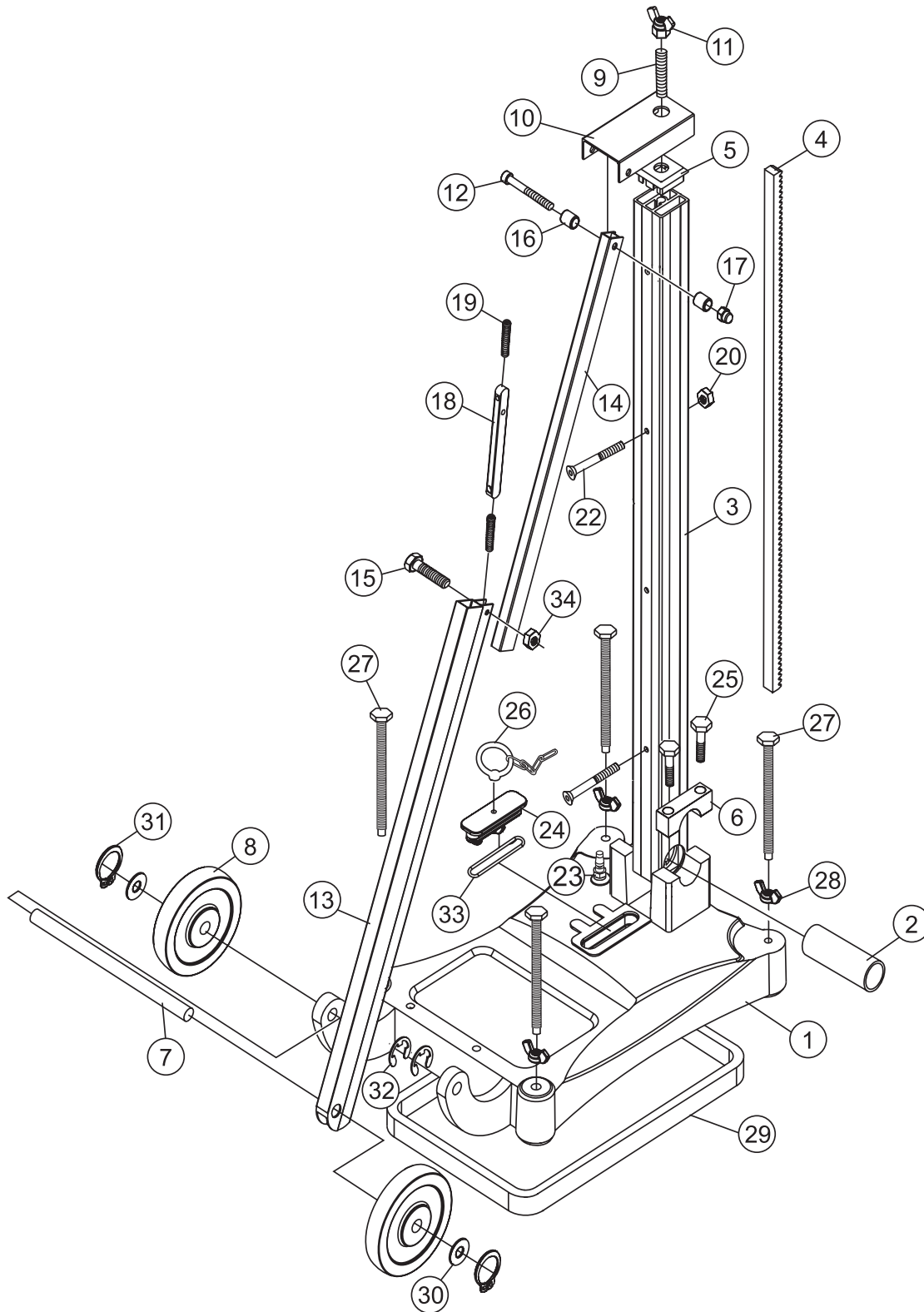

CDM2CSA — DRILLING RIG ASSEMBLY

DRILLING RIG ASSY.

<u>NO.</u>	<u>PART NO.</u>	<u>PART NAME</u>	<u>QTY.</u>	<u>REMARKS</u>
1	CD290072	BASE	1	
2	CD290073	POLE TUBE	1	
3	CD290074	POLE	1	
4	CD290075	RACK	1	
5	CD290076	POLE COVER	1	
6	CD290077	FIXED PLATE	2	
7	CD290078	WHEEL SHAFT	1	
8	CD290097	WHEELS, 4"	2	
9	CD290079	SCREW, M12X50 MM	1	
10	CD290080	ANGLE ADJUSTMENT BRACKET	1	
11	CD290081	ADJUST NUT, M12	1	
12	CD290082	SCREW, M8X60 MM	1	
13	CD290083	ANGLE ADJUST TUBE-2	1	
14	CD290084	ANGLE ADJUST TUBE-1	1	
15	CD290085	SCREW, M6X20 MM	1	
16	CD290086	METAL COLLAR	1	
17	CD290087	NUT	1	
18	CD290088	SHIFTER	1	
19	CD290089	SCREW, M6X35 MM	1	
20	CD290090	NUT, M6	1	
21	CD290091	SPRING	1	
22	CD290092	SCREW, M6X55 MM	4	
23	CD290093	VALVE	1	
24	CD290094	AIR COVER	1	
25	CD290095	SCREW, M12X40 MM	4	
26	CD290096	CHAIN PIN	1	
27	CD290098	SCREW, M12X100 MM	4	
28	CD290099	NUT, M12	4	
29	CD290100	GASKET	1	
30	CD290101	WASHER	4	
31	CD290102	S-RING, S1/2	2	
32	CD290103	E-RING, E12	2	
33	CD290104	O-RING, 3X53 MM	1	
34	CD290105	NUT, M6	1	

CDM2CSA — CRADLE ASSEMBLY

CRADLE ASSY.

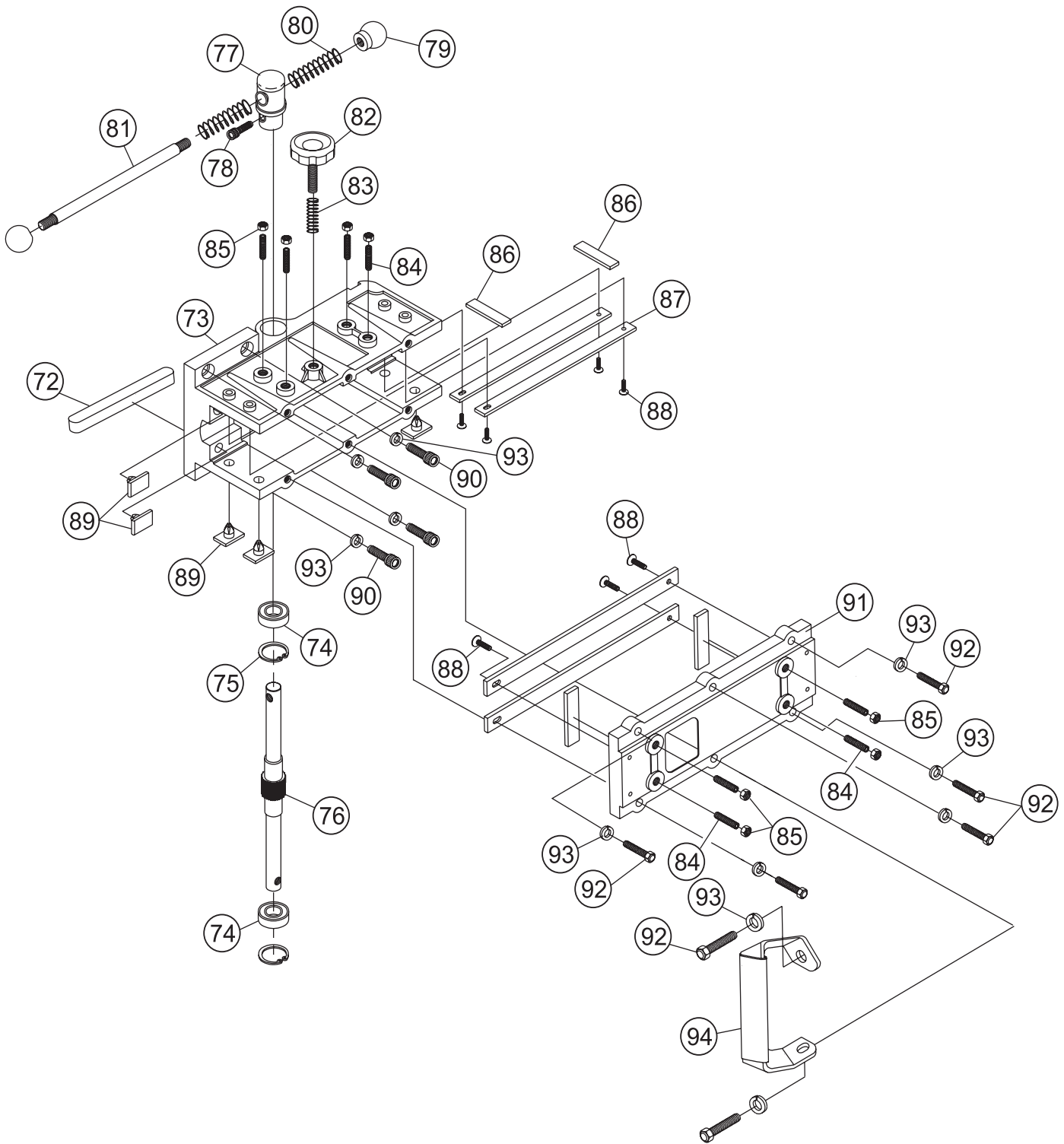

CRADLE ASSY.

<u>NO.</u>	<u>PART NO.</u>	<u>PART NAME</u>	<u>QTY.</u>	<u>REMARKS</u>
72	CD2704023	KEY, 10X10X105 MM	1	
73	CD2704064	FEEDING HOUSE	1	
74	CD2704065	BEARING, 6003ZZ	2	
75	CD2704066	SNAP RING	2	
76	CD2704067	FEED SHAFT	1	
77	CD2704071	FEEDING HEAD	1	
78	CD2704068	SCREW, M8X25 MM	1	
79	CD2704069	KNOB	2	
80	CD2704070	SPRING	2	
81	CD2704072	FEEDING HANDLE	1	
82	CD2704073	KNOB BOLT	1	
83	CD2704074	SPRING	1	
84	CD2704075	SET SCREW, M6X20 MM	6	
85	CD2704076	HEX, NUT, M6	8	
86	CD2704077	PLATE	4	
87	CD2704078	FRI CTION PLATE-LONG	4	
88	CD2704079	SCREW, 5/32X1/2"	8	
89	CD2704080	FRICTION PLATE-SHORT	8	
90	CD2704081	SCREW, M8X30 MM	4	
91	CD2704082	FEEDING HOUSE COVER	1	
92	CD2704083	SCREW, M8X20 MM	6	
93	CD2704110	WASHER, LOCK M8	10	
94	CD2704085	HANDLE	1	

TOOLS

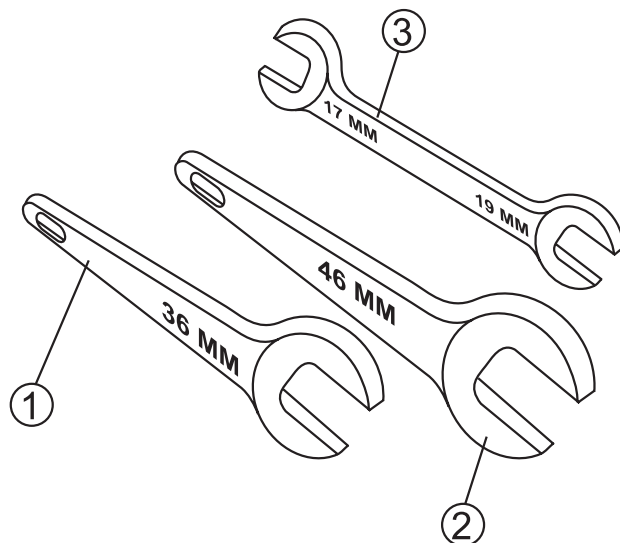

TOOLS

<u>NO.</u>	<u>PART NO.</u>	<u>PART NAME</u>	<u>QTY.</u>	<u>REMARKS</u>
1	CD2704103	36 MM WRENCH	1	
2	CD290008	46 MM WRENCH	1	
3	CD290106	17/19 MM WRENCH	1	

PAYMENT TERMS

Terms of payment for parts are net 10 days.

FREIGHT POLICY

All parts orders will be shipped collect or prepaid with the charges added to the invoice. All shipments are F.O.B. point of origin. Multiquip's responsibility ceases when a signed manifest has been obtained from the carrier, and any claim for shortage or damage must be settled between the consignee and the carrier.

MINIMUM ORDER

The minimum charge for orders from Multiquip is \$15.00 net. Customers will be asked for instructions regarding handling of orders not meeting this requirement.

RETURNED GOODS POLICY

Return shipments will be accepted and credit will be allowed, subject to the following provisions:

1. A Returned Material Authorization must be approved by Multiquip prior to shipment.
2. To obtain a Return Material Authorization, a list must be provided to Multiquip Parts Sales that defines item numbers, quantities, and descriptions of the items to be returned.
 - a. The parts numbers and descriptions must match the current parts price list.
 - b. The list must be typed or computer generated.
 - c. The list must state the reason(s) for the return.
 - d. The list must reference the sales order(s) or invoice(s) under which the items were originally purchased.
 - e. The list must include the name and phone number of the person requesting the RMA.
3. A copy of the Return Material Authorization must accompany the return shipment.
4. Freight is at the sender's expense. All parts must be returned freight prepaid to Multiquip's designated receiving point.
5. Parts must be in new and resalable condition, in the original Multiquip package (if any), and with Multiquip part numbers clearly marked.
6. The following items are not returnable:
 - a. Obsolete parts. (If an item is in the price book and shows as being replaced by another item, it is obsolete.)
 - b. Any parts with a limited shelf life (such as gaskets, seals, "O" rings, and other rubber parts) that were purchased more than six months prior to the return date.
 - c. Any line item with an extended dealer net price of less than \$5.00.
 - d. Special order items.
 - e. Electrical components.
 - f. Paint, chemicals, and lubricants.
 - g. Decals and paper products.
 - h. Items purchased in kits.
7. The sender will be notified of any material received that is not acceptable.
8. Such material will be held for five working days from notification, pending instructions. If a reply is not received within five days, the material will be returned to the sender at his expense.
9. Credit on returned parts will be issued at dealer net price at time of the original purchase, less a 15% restocking charge.
10. In cases where an item is accepted, for which the original purchase document can not be determined, the price will be based on the list price that was effective twelve months prior to the RMA date.
11. Credit issued will be applied to future purchases only.

PRICING AND REBATES

Prices are subject to change without prior notice. Price changes are effective on a specific date and all orders received on or after that date will be billed at the revised price. Rebates for price declines and added charges for price increases will not be made for stock on hand at the time of any price change.

Multiquip reserves the right to quote and sell direct to Government agencies, and to Original Equipment Manufacturer accounts who use our products as integral parts of their own products.

SPECIAL EXPEDITING SERVICE

A \$35.00 surcharge will be added to the invoice for special handling including bus shipments, insured parcel post or in cases where Multiquip must personally deliver the parts to the carrier.

LIMITATIONS OF SELLER'S LIABILITY

Multiquip shall not be liable hereunder for damages in excess of the purchase price of the item with respect to which damages are claimed, and in no event shall Multiquip be liable for loss of profit or good will or for any other special, consequential or incidental damages.

LIMITATION OF WARRANTIES

No warranties, express or implied, are made in connection with the sale of parts or trade accessories nor as to any engine not manufactured by Multiquip. Such warranties made in connection with the sale of new, complete units are made exclusively by a statement of warranty packaged with such units, and Multiquip neither assumes nor authorizes any person to assume for it any other obligation or liability whatever in connection with the sale of its products. Apart from such written statement of warranty, there are no warranties, express, implied or statutory, which extend beyond the description of the products on the face hereof.

OPERATION AND PARTS MANUAL

HERE'S HOW TO GET HELP

PLEASE HAVE THE MODEL AND SERIAL
NUMBER *ON-HAND* WHEN CALLING

UNITED STATES

Multiquip Corporate Office

18910 Wilmington Ave. Tel. (800) 421-1244
Carson, CA 90746 Fax (800) 537-3927
Contact: mq@multiquip.com

Mayco Parts

800-306-2926 Fax: 800-672-7877
310-537-3700 Fax: 310-637-3284

Service Department

800-421-1244 Fax: 310-537-4259
310-537-3700

MQ Parts Department

800-427-1244 Fax: 800-672-7877
310-537-3700 Fax: 310-637-3284

Warranty Department

800-421-1244, Ext. 279 Fax: 310-537-1173
310-537-3700, Ext. 279

Technical Assistance

800-478-1244 Fax: 310-631-5032

MEXICO

MQ Cipsa

Carr. Fed. Mexico-Puebla KM 126.5 Tel: (52) 222-225-9900
Momoxpan, Cholula, Puebla 72760 Mexico Fax: (52) 222-285-0420
Contact: pmastretta@cipsa.com.mx

CANADA

Multiquip

4110 Industriel Boul. Tel: (450) 625-2244
Laval, Quebec, Canada H7L 6V3 Fax: (450) 625-8664
Contact: jmartin@multiquip.com

UNITED KINGDOM

Multiquip (UK) Limited Head Office

Hanover Mill, Fitzroy Street, Tel: 0161 339 2223
Ashton-under-Lyne, Fax: 0161 339 3226
Lancashire OL7 0TL
Contact: sales@multiquip.co.uk

BRAZIL

Multiquip

Av. Evandro Lins e Silva, 840 - grupo 505 Tel: 011-55-21-3433-9055
Barra de Tijuca - Rio de Janeiro Fax: 011-55-21-3433-9055
Contact: cnavarro@multiquip.com.br, srentes@multiquip.com.br

© COPYRIGHT 2005, MULTIQUIP INC.

Multiquip Inc, the MQ logo are registered trademarks of Multiquip Inc. and may not be used, reproduced, or altered without written permission. All other trademarks are the property of their respective owners and used with permission.

This manual MUST accompany the equipment at all times. This manual is considered a permanent part of the equipment and should remain with the unit if resold.

The information and specifications included in this publication were in effect at the time of approval for printing. Illustrations are based on the *DM15A9C Core Drill and CDM2CSA Drilling Rig*. Illustrations, descriptions, references and technical data contained in this manual are for guidance only and may not be considered as binding. Multiquip Inc. reserves the right to discontinue or change specifications, design or the information published in this publication at any time without notice and without incurring any obligations.

Your Local Dealer is:

