

D-SERIES

COMPACT TRACK LOADERS



JOHN DEERE





You asked. We “D”elivered.

Loaded with customer-inspired enhancements, all four of our D-Series Compact Track Loaders offer roomier operator stations, quieter pressurized cabs with best-in-class visibility, and swing-out doors. You also have a choice of numerous productivity-boosting options including electrohydraulic (EH) joysticks with selectable control pattern and variable boom and bucket speed settings. Other innovative advantages include a highly efficient and easy-to-clean V-plenum cooling system. And easier-starting electronic fuel-injected PowerTech™E diesels. As always, grouped checkpoints, advanced diagnostics, and wide-open access help speed servicing, minimize maintenance, and lower daily operating costs. Read on to learn more about the differences in our D-Series that help you get more done, more reliably, for less. Then talk to your John Deere dealer.



	319D	323D	329D	333D
Net peak power	47.1 kW (63 hp) @ 2,300 rpm	51.4 kW (69 hp) @ 2,300 rpm	59.6 kW (80 hp) @ 2,000 rpm	66.7 kW (89 hp) @ 2,400 rpm
Rated operating capacity	863 kg (1,900 lb.)	1042 kg (2,295 lb.)	1317 kg (2,900 lb.)	1498 kg (3,300 lb.)
Tipping load	2542 kg (5,600 lb.)	3257 kg (7,175 lb.)	3768 kg (8,300 lb.)	4279 kg (9,425 lb.)*

*With one-set standard counterweight.

Open wide and be wowed.

With a noticeably larger entryway and all-glass curved door providing wide-open access, getting in and out of our CTLs has never been easier. Operators are also going to like what they see inside the D-Series. All-around visibility is even more expansive, for a virtually unrestricted view that's second to none. The all-new pressurized cab is 50-percent quieter. More spacious, too, with an extra 152 mm (6 in.) of headroom. A more efficient and effective HVAC system, more comfortable suspension seat, ample storage, and optional AM/FM/weatherband radio all help keep an operator comfortably productive.

1. Standard amenities include a storage box, cup holder, 12-volt power port, iPod™/cell-phone holder, and other nice D'tails.
2. We've got your back with a sculpted mechanical-suspension seat (standard on 323D, 329D, and 333D) helping smooth the ride. For even more comfort, opt for an available fabric-covered air-suspension seat in cab-equipped models.
3. Although not exactly a sunroof, the bolt-on top window on cab-equipped CTLs removes quickly for increased ventilation and/or easy cleaning.





With 100-percent more front glass, a 50-percent larger top window, and lower side windows, it's easy to see why visibility is best in class. For clear sightlines to the action in front, beside, and behind you.

HVAC system delivers 50-percent more airflow to keep the operator comfortable year-round. Eight automotive-style vents can be directed from head to toe, as well as on the front glass for effective defrosting.

Optional cab is sealed and pressurized to keep out dust and noise. Plus, it's 50-percent quieter, so you'll be able to hear the optional radio.

Pull-down padded lap bar provides quick, convenient operator restraint. It's adjustable up or down to provide comfortable arm support.

Triple-interlock operator-presence system automatically applies the brakes when the lap bar is raised, operator leaves the seat, or the engine is shut down.

Do things your way.

With three different styles of available controls on all four D-Series models, you decide how the work gets done. Foot controls are standard. Or opt for hands-only levers, or EH joysticks for steering, forward/reverse, and boom/bucket functions. EH joysticks provide low-effort fingertip control and smooth machine response. Add the optional EH Performance Package and you can customize performance for specific tasks or conditions.



1



2



3



1. Overhead panel conveniently places machine info on the left and control switches to the right. Easy-to-read LCD monitor provides access to a wealth of machine info and control, including vital operating conditions and advanced diagnostics.

2. Fatigue-beating joysticks allow you to work more productively, precisely, and comfortably. Buttons, triggers, and dial control auxiliary hydraulics and flow rates, two-speed transmission, and bucket float.

3. Want to make the most of our vertical-lift boom design? Add the self-leveling option. Combined with parallel-lift throughout the lift path, it's perfect for a multitude of material-handling tasks.



Optional hands-only controls and EH joysticks come equipped with a floor-mounted foot throttle.

Electronic rotary throttle lets you dial-in the engine speed you need for maximum fuel economy or full engine power.

Available with optional joysticks, the EH Performance Package lets an operator customize skid-steer operation and response to personal preferences:

- **Creeper mode** decreases ground speed in 10-percent increments while maintaining maximum hydraulic flow. It's ideal for work with cold planers or trenchers.
- **Boom and bucket speed-rate limits:**
 - **Precision mode** limits top speed and provides precise hydraulic metering for work near critical structures.
 - **Utility mode** provides smooth and balanced metering for normal operation.
 - **Production mode** delivers faster joystick response for stockpiling and truck loading where precision isn't as important.
- **Switchable control pattern** goes from ISO to H-pattern at the touch of a fingertip.

Optional digital-coded anti-theft system includes automatic end-of-day activation.

Get on the right tracks.

Want a CTL that's more able? Choose ours. With more breakout force, tractive effort, ground speed, and bucket capacity, all four deliver unmatched performance in virtually every significant category. And with their optimal weight distribution, low center of gravity, high ground clearance, and superior balance, no other compact track loader is as stable. Or as sure-footed on slopes.





Nothing lifts like a Deere. With tipping-load capacities up to 4279 kg (9,425 lb.), these CTLs let you precisely place pallets and handle even the most daunting material-handling tasks.

Fuel-sipping PowerTech™ E diesel engines meet EPA Tier 3/EU Stage IIIA (329D, 333D) and EPA IT4/EU Stage IIIB (319D, 323D) regulations. Exclusive electronic injection delivers significant torque rise and more usable power. Saves fuel, reduces noise, and improves cold starting, too.

A change in the weather doesn't have to mean a change in plans. High-flotation tracks enable these compacts to work where rubber-tire machines can't.

Need a little more flotation or a little less width? A 400-mm (15.8 in.) track option lets you decrease ground pressure on the 323D. Or narrow the stance of the 333D.

Make the most of your investment.

With their go-everywhere undercarriage, standard auxiliary hydraulics, and universal Quik-Tatch™, D-Series CTLs are highly versatile machines. To take full advantage of their capabilities, add any of the many available Worksite Pro™ attachments. Our ever-expanding lineup includes more than 100 choices that can help you get work done more easily. And expand your business opportunities. To learn more about the entire Worksite Pro attachment lineup, see your John Deere dealer.



Available attachments:

- | | |
|--|-----------------------------|
| Ag forks | Pallet forks |
| Augers | Power rakes |
| Backhoes | Rock buckets |
| Bale spears (round, square) | Roller levels |
| Blades (snow, utility) | Rotary cutters |
| Breakers/hammers | Rotary tillers |
| Brooms (angle, pickup) | Scrapers (material, manure) |
| Cold planers | Side-discharge buckets |
| Dozer blades | Snow blowers |
| Grapples (ag utility,
brush-tined, scrap) | Snow pushers |
| Landplanes | Toothbar |
| Mulching head | Trenchers |
| Multipurpose buckets | 3-point hitch |
| | Vibratory rollers |



1. Whether you're planting trees or setting posts, we've got you covered. Our planetary auger is available with a wide variety of bit styles and diameters.

2. Landplanes provide a cost-efficient productive alternative for finish work. Front and rear cutting edges allow controlled grading and leveling in forward or reverse.

3. Rock buckets are ideal for removing debris and sifting and sorting material. Design retains rocks and refuse while grading.

4. Cleanup is quicker and easier with one of our tined or scrap grapples. Dual-action clamps provide superior material retention.

Nothing runs like a Deere, because nothing is built like one.

All CTLs travel on tracks, but that's where the similarity ends. Our D-Series boast numerous uptime-boosting advantages you don't find on other compact track loaders. Such as an innovative V-plenum cooling system with hydraulically driven fan. And electronic-ignition PowerTech E diesel engine. Other difference makers are more subtle, but no less significant. Beefier boom, integrated rear bumper, and heavier-duty power Quik-Tatch, to list just a few. Add to those a multitude of traditional John Deere durability advantages and the choice is easy. When you know how they're built, you'll run a Deere.





1. Industry-exclusive design separates coolers in an innovative V-shape configuration that's 20-percent more efficient. Large aluminum hydraulic cooler and radiator provide the necessary cooling capacity for high-ambient-temperature operation.
2. Hydraulic-driven variable-speed fan runs only as fast or as frequently as needed for improved power and fuel efficiency. Decreases noise and debris flow through the coolers, too. There's also an exclusive fan option that reverses automatically every 20 minutes, or at the click of a switch, to clear core-clogging buildup.
3. All-steel rollers, idlers, and sprockets are similar to those used on our highly durable larger crawlers. Metal-face seals and journal bearings further increase longevity.

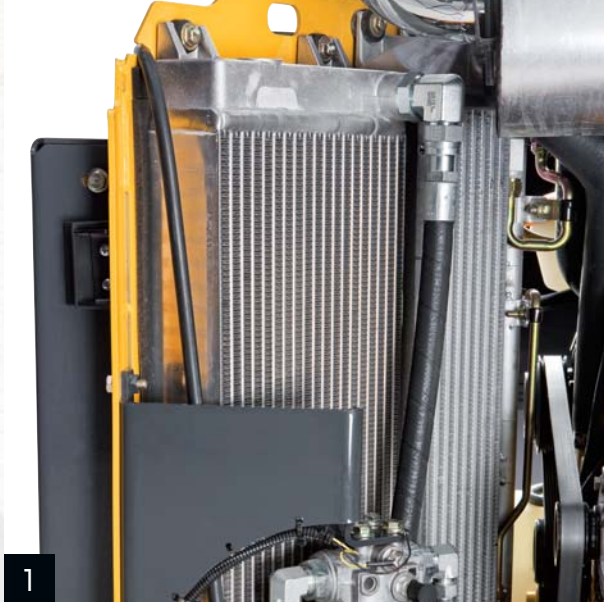

Heavy-duty double-steel-reinforced rubber tracks last longer than those on other machines. Easy-clean undercarriage shortens end-of-day cleanout and reduces track wear due to dirt buildup.

Drive motors are heavy duty, and hoses are shielded for extra protection. Direct-mounted planetary final drives employ larger-than-usual bearings for one-of-a-kind reliability.

Spring-applied, hydraulic-released wet-disc park brakes are fully enclosed and never require adjustment.

O-ring face-seal hydraulic fittings virtually eliminate aggravating and costly oil leaks.

Switches and electrical connectors are sealed from moisture and dirt to help prevent corrosion.

Auto-shutdown system monitors engine and hydraulic vitals, and issues an audible warning when limits are exceeded. If necessary, it shuts down the machine to help prevent damage.

Getting to the heart of a Deere is easy. There's no need to raise the boom — just pivot the cab and remove the floor. Takes only minutes.

To help conserve fuel and prolong engine life, standard auto-idle reduces engine speed after the operator has vacated the seat. Full auto-idle (available with EH controls) slows the engine after five seconds of inactivity, and resumes preset engine speed with any movement of the joysticks.

Fluid-fill locations and checkpoints are grouped and color-coded. And a conveniently displayed maintenance chart helps ensure that nothing gets overlooked.

V-plenum design resists debris buildup and makes radiator and cooler cores easier to clean.

Unlike some CTLs that require complicated daily adjustments with special tools, track tension is checked weekly. If adjustment is necessary, all that's needed is a wrench and grease gun.

Compare the cost of parts and labor for recommended maintenance with other makes. The D-Series will save you significant money. Add the long-term expense for undercarriage replacement, and the savings can be substantial.



We've lowered the boom on maintenance.

Servicing a D-Series CTL is simple and quick. So simple, in fact, that you won't even have to raise the boom for daily service, or most periodic maintenance. Checkpoints are grouped beneath the hinged hood, and easily removable side panels give way to the coolers, maintenance-free battery, and fluid and air filters. If necessary, the operator station can be tilted in minutes for best-in-class drivetrain access. And industry-leading parts and service are just as accessible at more than 1,200 John Deere dealer locations from coast to coast.

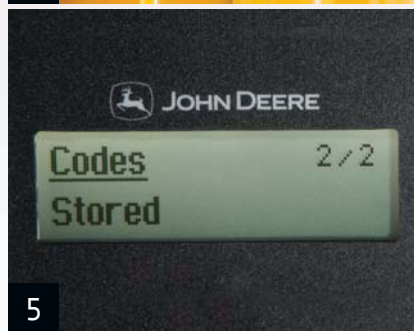

1. Daily servicing is quick and convenient. Simply lift the hood for ground-level access to check fluids and to refuel.

2. Need extra elbow-room? Raise the boom for wide-open engine-compartment access. Unique lock lever secures the boom from inside the cab.

3. Hydraulic sight gauge and see-through coolant and windshield washer fluid reservoirs let you check levels at a glance.

4. Spin-on filters and environmental drains allow quick fluid changes.

5. Through-the-monitor onboard diagnostics help speed troubleshooting.

6. Because no maintenance beats low maintenance, serpentine belt and hydraulic engine-valve lifters never require adjustment.

319D / 323D

Engine	319D	323D
Manufacturer and Model	John Deere PowerTech™ E 4024HT	John Deere PowerTech E 4024HT
Non-Road Emissions Standard	EPA Interim Tier 4/EU Stage IIIB	EPA Interim Tier 4/EU Stage IIIB
Cylinders	4	4
Net Peak Power (SAE J1349 / ISO 9249)	47.1 kW (63 hp) at 2,300 rpm	51.4 kW (69 hp) at 2,300 rpm
Gross Peak Power (ISO 14396)	50.8 kW (68 hp) at 2,300 rpm	55.0 kW (74 hp) at 2,200 rpm
Peak Torque	230 Nm (170 ft.-lb.) at 2,000 rpm	260 Nm (192 ft.-lb.) at 2,000 rpm
Displacement	2.4 L (149 cu. in.)	2.4 L (149 cu. in.)
Net Torque Rise	27% at 1,600 rpm	38% at 1,800 rpm
Aspiration	Turbocharged and intercooled	Turbocharged and intercooled
Air Cleaner	Dry dual element	Dry dual element
Cooling	319D / 323D	
Fan Drive	Variable-speed hydraulic drive	
Powertrain	319D	323D
Pump	Axial-piston hydrostatic	Axial-piston hydrostatic
Travel Speeds		
Single Speed	9.8 km/h (6.1 mph)	9.8 km/h (6.1 mph)
2 Speed, Optional		
Low	—	8.9 km/h (5.5 mph)
High	—	13.7 km/h (8.5 mph)
Brake	Integral, automatic, spring applied, hydraulically released wet-disc brake	
Undercarriage	New-generation smooth-ride long-life rubber with steel inserts	
Rubber Tracks	New-generation smooth-ride long-life rubber with steel inserts	
Track Width		
Standard	320 mm (12.6 in.)	320 mm (12.6 in.)
Optional	—	400 mm (15.8 in.)
Ground Pressure		
Standard 320-mm (12.6 in.) Track	37.2 kPa (5.4 psi)	37.2 kPa (5.4 psi)
Optional 400-mm (15.8 in.) Track	—	30.6 kPa (4.4 psi)
Track Rollers (per side)	4 triple-flange smooth-ride all-steel rollers	4 triple-flange smooth-ride all-steel rollers
Track Idlers (per side)	2 double-flange smooth-ride all-steel rollers	2 double-flange smooth-ride all-steel rollers
Bearings/Seals (rollers/idlers)	Heavy-duty journal bearings and metal face seals	Heavy-duty journal bearings and metal face seals
Tractive Effort	3629 kgf (8,000 lbf)	3629 kgf (8,000 lbf)
Hydraulics		
Pump Flow		
Standard	59 L/m (15.5 gpm)	72 L/m (19 gpm)
High-Flow Option Total	—	110 L/m (29 gpm)
System Pressure at Couplers	21 374 kPa (3,100 psi)	23 787 kPa (3,450 psi)
Hydraulic Horsepower (calculated)		
Standard Flow	22.4 kW (30 hp)	29.8 kW (40 hp)
High-Flow Option	—	46.2 kW (62 hp)
Cylinders	319D / 323D	
John Deere heat-treated, chrome-plated, polished cylinder rods, hardened steel (replaceable bushings) pivot pins		
Electrical		
Voltage	12 volt	
Battery Capacity	750 CCA (optional 925 CCA)	
Alternator Rating	70 amp	
Lights	Halogen, 2 front and 1 rear standard	
Operator's Station		
ROPS (ISO 3471)/FOPS (ISO 3449) structure with quick-pivot standard		
Serviceability		
Refill Capacities		
Fuel Tank	70.0 L (19.0 gal.)	



Operating Weights	319D	323D
Track		
320-mm (12.6 in.) Standard	3882 kg (8,550 lb.)	3882 kg (8,550 lb.)
400-mm (15.8 in.) Optional	—	3984 kg (8,775 lb.)
Machine Dimensions		
A Length without Bucket	2.74 m (9 ft. 0 in.)	2.74 m (9 ft. 0 in.)
B Length	3.36 m (11 ft. 0 in.)	3.36 m (11 ft. 0 in.)
C Width without Bucket		
With 320-mm (12.6 in.) Track	1.82 m (6 ft. 0 in.)	1.82 m (6 ft. 0 in.)
With 400-mm (15.7 in.) Track	—	1.91 m (6 ft. 3 in.)
D Height to Top of ROPS	2.00 m (6 ft. 7 in.)	2.00 m (6 ft. 7 in.)
E Height to Hinge Pin	3.00 m (9 ft. 10 in.)	3.00 m (9 ft. 10 in.)
F Dump Height	2.40 m (7 ft. 11 in.)	2.40 m (7 ft. 11 in.)
G Dump Reach		
With Foundry Bucket	721 mm (28.4 in.)	721 mm (28.4 in.)
With Construction Bucket	0.92 m (3 ft. 0 in.)	0.92 m (3 ft. 0 in.)
H Ground Clearance	250 mm (9.8 in.)	250 mm (9.8 in.)
I Angle of Departure	25 deg.	25 deg.
J Front Turn Radius	2.01 m (6 ft. 7 in.)	2.01 m (6 ft. 7 in.)
K Dump Angle (full lift height)	42 deg.	42 deg.
L Bucket Rollback (ground level)	32 deg.	32 deg.

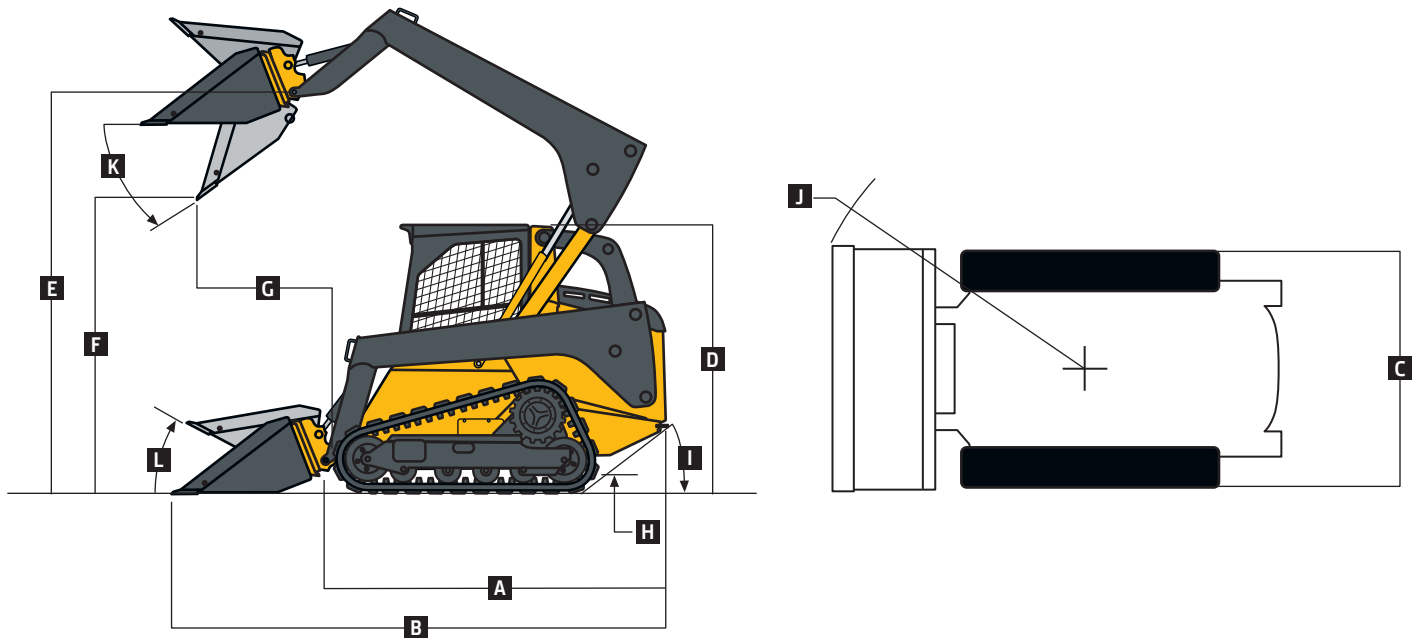

Loader Performance	319D	323D
Tipping Load	2542 kg (5,600 lb.)	3257 kg (7,175 lb.)
SAE Rated Operating Capacity with Foundry Bucket		
At 35% Tipping Load	863 kg (1,900 lb.)	1042 kg (2,295 lb.)
At 50% Tipping Load	1271 kg (2,800 lb.)	1634 kg (3,600 lb.)
Boom Breakout	1589 kg (3,500 lb.)	1680 kg (3,700 lb.)
Bucket Breakout Force	2327 kg (5,125 lb.)	2542 kg (5,600 lb.)

329D / 333D



Engine	329D	333D
Manufacturer and Model	John Deere PowerTech™ E 5030HT	John Deere PowerTech E 5030HT
Non-Road Emissions Standard	EPA Tier 3/EU Stage IIIA	EPA Tier 3/EU Stage IIIA
Cylinders	5	5
Net Peak Power (SAE J1349 / ISO 9249)	59.6 kW (80 hp) at 2,000 rpm	66.7 kW (89 hp) at 2,400 rpm
Gross Peak Power (ISO 14396)	63.4 kW (85 hp) at 2,200 rpm	71.1 kW (95 hp) at 2,400 rpm
Peak Torque	300 Nm (221 ft.-lb.) at 2,000 rpm	341 Nm (252 ft.-lb.) at 1,950 rpm
Displacement	3.0 L (186 cu. in.)	3.0 L (186 cu. in.)
Net Torque Rise	43.0% at 1,700 rpm	36.9% at 1,680 rpm
Aspiration	Turbocharged and intercooled	Turbocharged and intercooled
Air Cleaner	Dry dual element	Dry dual element
Cooling	329D / 333D	
Fan Drive	Variable-speed hydraulic drive	
Powertrain	329D	333D
Pump	Manual axial-piston hydrostatic-servo	Manual axial-piston hydrostatic-servo
Travel Speeds		
Single Speed	10.0 km/h (6.2 mph)	—
2 Speed, Optional		
Low	8.5 km/h (5.3 mph)	8.5 km/h (5.3 mph)
High	12.6 km/h (7.8 mph)	12.6 km/h (7.8 mph)
Brake	Integral, automatic, spring applied, hydraulically released wet-disc brake	
Undercarriage	New-generation smooth-ride long-life rubber with steel inserts	
Rubber Tracks	New-generation smooth-ride long-life rubber with steel inserts	
Track Width		
Standard	400 mm (15.8 in.)	450 mm (17.7 in.)
Optional	450 mm (17.7 in.)	400 mm (15.8 in.)
Ground Pressure		
400-mm (15.8 in.) Track (329D standard, 333D optional)	34.2 kPa (5.0 psi)	34.7 kPa (5.0 psi)
450-mm (17.7 in.) Track (329D optional, 333D standard)	30.6 kPa (4.4 psi)	31.1 kPa (4.5 psi)
Track Rollers (per side)	5 triple-flange smooth-ride all-steel rollers	5 triple-flange smooth-ride all-steel rollers
Track Idlers (per side)	2 double-flange smooth-ride all-steel rollers	2 double-flange smooth-ride all-steel rollers
Bearings/Seals (rollers/idlers)	Heavy-duty journal bearings and metal face seals	Heavy-duty journal bearings and metal face seals
Tractive Effort	5227 kgf (11,500 lbf)	5227 kgf (11,500 lbf)
Hydraulics		
Pump Flow		
Standard	80 L/m (21 gpm)	95 L/m (25 gpm)
High-Flow Option Total	125 L/m (33 gpm)	129 L/m (34 gpm)
System Pressure at Couplers	23 787 kPa (3,450 psi)	23 787 kPa (3,450 psi)
Hydraulic Horsepower (calculated)		
Standard Flow	34.3 kW (46 hp)	39.5 kW (53 hp)
High-Flow Option	53.7 kW (72 hp)	54.4 kW (73 hp)
Cylinders	329D / 333D	
John Deere heat-treated, chrome-plated, polished cylinder rods, hardened steel (replaceable bushings) pivot pins		
Electrical		
Voltage	12 volt	
Battery Capacity	925 CCA	
Alternator Rating	70 amp	
Lights	Halogen, 2 front and 1 rear standard	
Operator's Station		
ROPS (ISO 3471)/FOPS (ISO 3449) structure with quick-pivot standard		
Serviceability		
Refill Capacities		
Fuel Tank	111.0 L (29.0 gal.)	



Operating Weights	329D	333D
Track		
400-mm (15.8 in.) (329D standard, 333D optional)	4917 kg (10,830 lb.)	4994 kg (11,000 lb.)
450-mm (17.7 in.) (329D optional, 333D standard)	4962 kg (10,930 lb.)	5039 kg (11,100 lb.)
Machine Dimensions		
A Length without Bucket	2.99 m (9 ft. 10 in.)	2.99 m (9 ft. 10 in.)
B Length	3.60 m (11 ft. 10 in.)	3.60 m (11 ft. 10 in.)
C Width without Bucket		
With 400-mm (15.8 in.) Track	2.00 m (6 ft. 7 in.)	2.00 m (6 ft. 7 in.)
With 450-mm (17.7 in.) Track	2.05 m (6 ft. 9 in.)	2.05 m (6 ft. 9 in.)
D Height to Top of ROPS	2.15 m (7 ft. 1 in.)	2.15 m (7 ft. 1 in.)
E Height to Hinge Pin	3.20 m (10 ft. 6 in.)	3.20 m (10 ft. 6 in.)
F Dump Height	2.59 m (8 ft. 6 in.)	2.59 m (8 ft. 6 in.)
G Dump Reach		
With Foundry Bucket	819 mm (32.2 in.)	819 mm (32.2 in.)
With Construction Bucket	1.00 m (3 ft. 3 in.)	1.00 m (3 ft. 3 in.)
H Ground Clearance	265 mm (10.4 in.)	265 mm (10.4 in.)
I Angle of Departure	32 deg.	32 deg.
J Front Turn Radius	2.17 m (7 ft. 1 in.)	2.17 m (7 ft. 1 in.)
K Dump Angle (full lift height)	45 deg.	45 deg.
L Bucket Rollback (ground level)	35 deg.	35 deg.

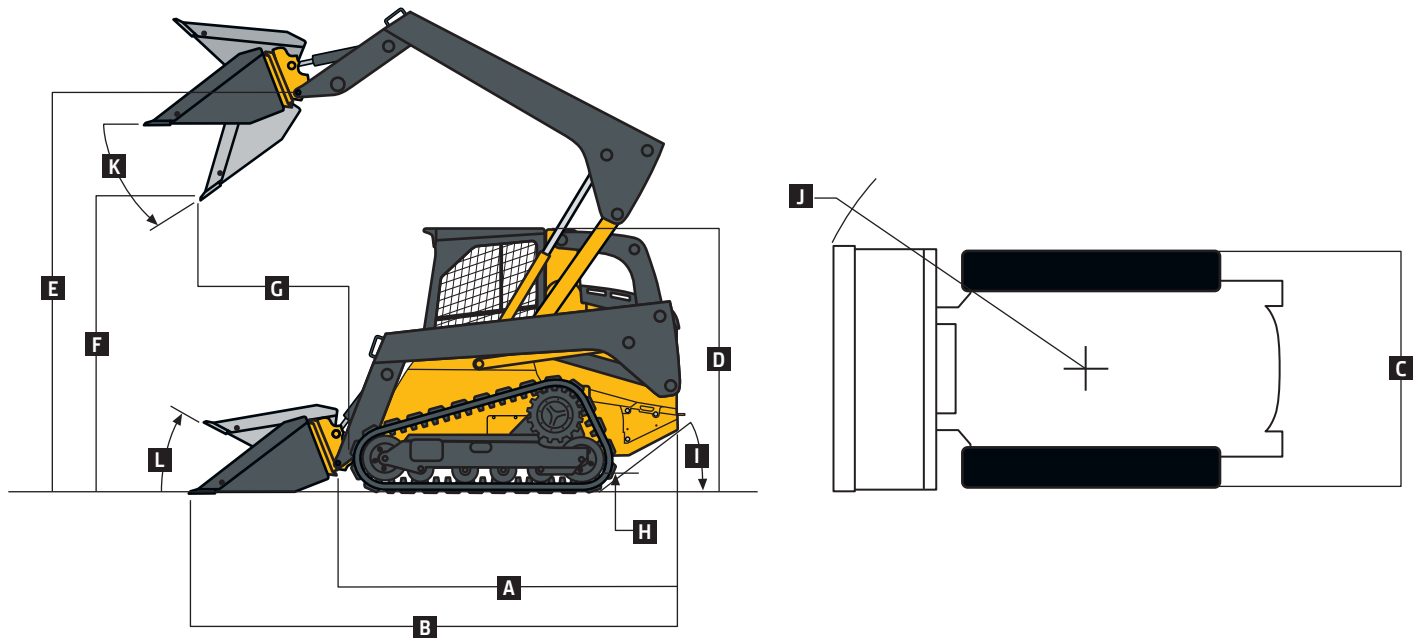

Loader Performance	329D	333D
Tipping Load	3768 kg (8,300 lb.)	4279 kg (9,425 lb.)*
SAE Rated Operating Capacity with Foundry Bucket		
At 35% Tipping Load	1317 kg (2,900 lb.)	1498 kg (3,300 lb.)
At 50% Tipping Load	1884 kg (4,150 lb.)	2145 kg (4,725 lb.)
Boom Breakout	2088 kg (4,600 lb.)	2996 kg (6,600 lb.)
Bucket Breakout Force	4688 kg (10,325 lb.)	6299 kg (13,875 lb.)

*With one-set standard counterweight.

Additional equipment

Key: ● Standard ▲ Optional or special

See your John Deere dealer for further information.

319	323	329	333	Engine
●	●			Meets EPA Interim Tier 4/EU Stage IIIB emissions
		●	●	Meets EPA Tier 3/EU Stage IIIA emissions
●	●			John Deere PowerTech™ E 4024HT
		●	●	John Deere PowerTech E 5030HT
●	●	●	●	Auto-idle
●	●	●	●	Automatic fan-belt tensioner
●	●	●	●	Automatic preheat
●	●	●	●	Electronic injection system
●	●	●	●	John Deere COOL-GARD™ II Extended-Life Engine Coolant
●	●	●	●	John Deere Plus-50™ 10w30 initial engine oil fill*
●	●	●	●	5-micron primary fuel filter and water separator
▲	▲	▲	▲	Cold-weather package
Cooling System				
●	●	●	●	Coolant recovery tank
●	●	●	●	Cool-on-demand cooling system
▲	▲	▲	▲	Reversing fan drive
Powertrain				
●	●	●	●	High-torque heavy-duty planetary-reduction final drive
●	●	●	●	Automatic spring-applied hydraulically released wet-disc park brakes
●	●	●	●	Transmission, single-speed
	▲	▲	●	Transmission, 2-speed
Hydraulic System				
●	●	●	●	John Deere hydraulic cylinders with cushioned boom cylinders
●	●	●	●	Quick-check hydraulic fluid-level sight glass
●	●	●	●	5-micron hydraulic filter
	▲	▲	▲	High-flow hydraulics
Electrical				
●	●	●	●	Automatic shutdown with alarm
●	●	●	●	Auxiliary hydraulics operator-presence system

319	323	329	333	Electrical (continued)
●	●	●	●	Deluxe instrumentation EMU with: Operator-selectable monitoring – Hour meter, engine rpm, battery voltage, diagnostics, EMU configuration, engine coolant temperature, hydraulic oil temperature / LED warning indicators – Glow plug, seat switch, seat belt, door open, auxiliary hydraulics, park brake engaged, 2-speed engaged, stop, low engine oil pressure, engine coolant over-temperature, battery not charging, air filter restriction, hydraulic filter restriction
●	●	●	●	Front and rear halogen work lights
●	●	●	●	Triple interlock operator-presence control system
▲	▲	▲	▲	Anti-theft system
▲	▲	▲	▲	Backup alarm
●	●			Battery, 750 CCA
▲	▲	●	●	Battery, 925 CCA
▲	▲	▲	▲	Hazard warning lights
▲	▲	▲	▲	Horn
▲	▲	▲	▲	Strobe light, amber
Operator's Station				
●	●	●	●	Adjustable foot pedals
●	●	●	●	Deluxe cab headliner
●	●	●	●	Electronic push-button auxiliary controls
●	●	●	●	Foot controls
▲	▲	▲	▲	Hand controls with foot throttle
●	●	●	●	Pull-down lap bar
●	●	●	●	Quick-pivot ROPS
●	●	●	●	Rear window
●	●	●	●	ROPS/FOPS operator structure
●	●	●	●	Seat belt, 51-mm (2 in.), retractable
▲	▲	▲	▲	Seat belt, 76-mm (3 in.)
▲	▲	▲	▲	Shoulder belt
●	●	●	●	Top window
▲	▲	▲	▲	Removable top window

319	323	329	333	Operator's Station (continued)
▲	▲	▲	▲	Side window kit
●				Water-shedding deluxe vinyl seat
▲	●	●	●	Deluxe vinyl suspension seat
▲	▲	▲	▲	Air-ride (cloth) seat
●	●	●	●	12-volt power port / Dome light / Cargo storage / Beverage holder
▲	▲	▲	▲	Air conditioning with heater/defroster
▲	▲	▲	▲	AM/FM/weatherband radio with auxiliary input
▲	▲	▲	▲	Cab enclosure
▲	▲	▲	▲	Severe-duty cab door
▲	▲	▲	▲	Electrohydraulic joystick controls
▲	▲	▲	▲	Electrohydraulic performance package with attachment controller
▲	▲	▲	▲	Floor mat
▲	▲	▲	▲	Floor mat with left footrest
▲	▲	▲	▲	Heater with defroster
▲	▲	▲	▲	Heavy-duty rear grille
▲	▲	▲	▲	Rearview mirror
Loader				
●	●	●	●	Integral cab boom lock
●	●	●	●	Patented John Deere Quik-Tatch™ (no grease required)
▲	▲	▲	▲	Power Quik-Tatch
●	●	●	●	Patented John Deere vertical-lift boom with superior visibility
▲	▲	▲	▲	Hydraulic self-leveling on/off
Other				
●	●	●	●	Convenient front and rear tie-downs
●	●	●	●	Environmental drains for all fluid reservoirs
▲	▲	▲	▲	Chrome exhaust stack
▲	▲	▲	▲	Modular rear-weight packages
▲	▲	▲	▲	Single-point lift kit
▲	▲	▲	▲	SMV sign kit
●	●			Track, 320-mm (12.6 in.) wide
	▲	●	▲	Track, 400-mm (15.8 in.) wide
		▲	●	Track, 450-mm (17.7 in.) wide

*500-hour engine oil-change intervals when John Deere Plus-50 oil and John Deere oil filter are used.



Net engine power is with standard equipment including air cleaner, exhaust system, alternator, and hydraulic cooling fan at test conditions per ISO 9249. Gross power is without cooling fan. Specifications and design subject to change without notice. Wherever applicable, specifications are in accordance with SAE and ISO standards. Except where otherwise noted, these specifications are based on units with full fuel tanks and 79-kg (175 lb.) operators; 319D and 323D units with standard 320-mm (12.6 in.) tracks; a 329D unit with standard 400-mm (15.8 in.) tracks; and a 333D unit with standard 450-mm (17.7 in.) tracks.

www.JohnDeere.com