



OPERATOR MANUAL

Includes Safety, Service and Replacement Part Information

300 Series Hole Digger

Models:

310F, 342F, 356F
330B, 330H, 330T
343B, 343H, 343T
357B, 357H, 357T

Form: GOM4109801
Version 2.0

Do not discard this manual. Before operation, read and comprehend its contents. Keep it readily available for reference during operation or when performing any service related function. When ordering replacement parts, please supply the following information: model number, serial number and part number. For customer service assistance, telephone 800.533.0524, +507.451.5510. Our Customer Service Department telefax number is 877.344.4375 (DIGGER 5), +507.451.5511. There is no charge for customer service activities .

Internet address: <http://www.generalequip.com>.
E-Mail: general@generalequip.com.

Copyright 2003, General Equipment Company.



General[®]
EQUIPMENT COMPANY

620 Alexander Dr. S.W. • PO Box 334
Owatonna, Minnesota 55060
800.533.0524 • +507.451.5510
Fax +507.451.5511
Toll-Free Fax 877.344.4375 (Digger 5)
Web: www.generalequip.com
E-mail: general@generalequip.com
Can you really afford anything less?



Congratulations on your decision to purchase a General light construction product. From our humble beginnings in 1955, it has been a continuing objective of General Equipment Company to manufacture equipment that delivers uncompromising value, service life and investment return. Because of this continuous commitment for excellence, many products bearing the General name actually set the standards by which competitive products are judged.

When you purchased this product, you also gained access to a team of dedicated and knowledgeable support personnel that stand willing and ready to provide field support assistance. Our team of sales representatives and in house factory personnel are available to ensure that each General product delivers the intended performance, value and investment return. Our personnel can readily answer your concerns or questions regarding proper applications, service requirements and warranty related problems.

General Equipment Company places great emphasis upon not only product performance, but also on product safety. It is important to remember that this product will only be as safe as the operators which utilize it. It just makes good, common sense to take the time to read and fully understand the contents of this manual before attempting to utilize this product in service. If you ever do have any questions or concerns about this product, please feel free to contact our Customer Service Department at the telephone numbers listed below for assistance.

If there is anything that I can do to assist your efforts when utilizing this product, please do not hesitate to contact me. For assistance after normal business hours, telephone me at 507.451.9409 or 507.363.1033. If I am not immediately available, I will attempt to return your call as soon as possible.

Sincerely,

GENERAL EQUIPMENT COMPANY

Dennis Von Ruden
President

Table of Contents

DESCRIPTION	PAGE
<i>Notice to Operators</i>	4
<i>Operational Instructional Data Sheet</i>	5
<i>Safety Precautions</i>	
PREPARATION.	7
OPERATION.	8
MAINTENANCE, REPAIR AND STORAGE.	10
<i>Assembly</i>	
INSTALLING THE COMPOSITE MATERIAL OPERATOR HANDLES, Models 310F, 342F, and 356F.	11
INSTALLING THE COMPOSITE MATERIAL OPERATOR HANDLES, Models 330B, 343B, and 357B.	14
INSTALLING THE COMPOSITE MATERIAL OPERATOR HANDLES, Models 330H, 343H, and 357H.	17
NOTES TO THE THROTTLE CABLE INSTALLATION, Models 330H, 343H, 357H	19
INSTALLING THE COMPOSITE MATERIAL OPERATOR HANDLES, Models 330T, 343T, and 357H.	20
<i>Before Starting the Engine</i>	
FILLING THE ENGINE CRANKCASE WITH OIL, 4 Cycle Models.	23
FILLING THE HOLE DIGGER TRANSMISSION WITH OIL, ALL Models.	23
TRANSMISSION OIL RECOMMENDATIONS, ALL MODELS.	24
FILLING THE ENGINE FUEL TANK, Models 310F, 342F and 356F.	24
FILLING THE ENGINE FUEL TANK, ALL 4 Cycle Models.	25
<i>Digging Operation</i>	
OPERATIONAL DISCLAIMER.	26
CALIFORNIA PROPOSITION 65 DISCLAIMER.	26
SPARK ARRESTER DISCLAIMER.	26
INFORMATION RELATIVE TO MINIMUM COMPONENT STANDARDS FOR THE .	26
OPERATION OF THE HOLE DIGGER.	
INFORMATION RELATIVE TO COMPOSITE MATERIAL OPERATOR HANDLES.	27
GENERAL TRANSPORTATION INFORMATION.	28
DETERMINATION OF POTENTIAL SUBSURFACE HAZARDS IN THE PROPOSED DIGGING LOCATION(S).	28
SET UP FOR DIGGING.	29
STARTING THE ENGINE WITH THE AUGER ATTACHED, Models 310F, 342F and 356F.	29
STARTING THE ENGINE WITH THE AUGER ATTACHED, Models 330B, 343B and 357B.	31
STARTING THE ENGINE WITH THE AUGER ATTACHED, Models 330H, 343H and 357H.	32
STARTING THE ENGINE WITH THE AUGER ATTACHED, Models 330T, 343T and 357T.	33
OPERATING THE HOLE DIGGER.	34
UNDERSTANDING KICKBACK.	35
MINIMIZING KICKBACK FROM AN OPERATIONAL STANDPOINT.	35
MINIMIZING KICKBACK FROM A DESIGN STANDPOINT.	36
OPERATING THE HOLE DIGGER CONTINUED.	37
STOPPING THE HOLE DIGGER, Models 310F, 342F, and 356F.	40

STOPPING THE HOLE DIGGER, ALL 4 Cycle Models.	40
TEMPORARY STORAGE FOR THE HOLE DIGGER WHILE ON THE JOB SITE.	40
ADDING AND REMOVING NONFLIGHTED AND FULL FLIGHTED AUGER EXTENSIONS.	41
<i>Service</i>	
CHANGING THE HOLE DIGGER TRANSMISSION OIL.	43
MAGURA THROTTLE CONTROL MAINTENANCE PROGRAM.	44
AUGER MAINTENANCE PROGRAM.	45
REPLACING A WORN AUGER SCREW BIT.	45
REPLACING WORN AUGER TEETH.	46
ENGINE SERVICE.	47
<i>Troubleshooting</i>	
ENGINE.	48
OPERATIONAL PROBLEMS.	48
<i>Repair</i>	
BASIC INFORMATION.	49
TRANSMISSION OIL SEAL REMOVAL AND INSTALLATION.	50
CENTRIFUGAL CLUTCH REMOVAL AND INSTALLATION, Models 310, 310F, 342F and 356F.	53
CENTRIFUGAL CLUTCH REMOVAL AND INSTALLATION, Models 330, 330B, 343B, 357B, 330T, 343T and 357T.	55
CENTRIFUGAL CLUTCH REMOVAL AND INSTALLATION, Models 330H, 343H and 357H.	56
<i>Storage</i>	58
<i>Specifications</i>	59
<i>Replacement Parts Diagrams</i>	63

Notice to Operators

IF YOU CAN NOT READ OR DO NOT FULLY UNDERSTAND THE CONTENTS OF THIS MANUAL, PLEASE CONTACT THE FACTORY FOR PROPER ASSISTANCE BEFORE ATTEMPTING TO OPERATE THIS PRODUCT.

SI TU NO PUEDES LEER O NO COMPRENDES EL CONTENIDO DE ESTE MANUAL FAVOR DE PONERSE EN CONTACTO CON LA FABRICA PARA ASISTENCIA- A PROPIA ANTES DE INTENTAR PARA OPERAR ESTE PRODUCTO.

SOLLTEN SIE DIESE GEBRAUCHSANWEISUNG NICHT LESEN KOENNEN ODER ES NICHT VOLLKOMMEN VERSTEHEN, WENDEN SIE SICH BITTE AN DEN HERSTELLER FUER RICHTIGE HILFE EHE SIE VERSUCHEN DIESES PRODUKT ZU OPERIEREN.

SI VOUS NE LISEZ OU NE COMPRENDRE ENTIEREMENT LES MATIERES DE CE MANUEL, SIL VOUS PLAIT, CONTACTEZ L USINE POUR L ASSISTANCE APPROPRIEE AVANT D UTILISER LE PRODUIT.



DANGER



CAUTION

These safety alert symbols identify important safety messages in this manual. When you see these symbols, be alert to the possibility of personal injury and carefully read the message that follows.

Do not allow anyone to operate the Hole Digger without first reading this Operator Manual and becoming familiar with its operation. The manufacturer of this Hole Digger has gone to great extremes to provide the owner(s) and/or operator(s) with the finest equipment available for its intended job function of digging vertical holes in unconsolidated and specific semiconsolidated earth formations. Yet, the possibility exists that the Hole Digger can be utilized in and/or subjected to job applications not perceived and/or anticipated by the manufacturer. Such misuse and/or misapplication of the Hole Digger can lead to the possibility of serious damage, injury or even death. It is the responsibility of the owner(s) and/or operator(s) to determine that the Hole Digger is being utilized and/or operated within the scope of its intended job function. It is the responsibility of the owner(s) and/or operator(s) to establish, monitor and constantly upgrade all safety programs and/or practices utilized in and for the operation of the Hole Digger. The purpose of such programs is to provide for owner(s)' and/or operator(s)' safety. Operators must be instructed to recognize and avoid unsafe conditions associated with their work (29 CFR 1926.21 (b)(2)) and/or applicable updated revisions. It is the responsibility of the owner(s) and/or operator(s) to determine that no modifications and/or alterations have been made to the Hole Digger. Modifications and/or alterations can lead to the possibility of serious damage, injury or even death. It is the responsibility of the owner(s) and/or operator(s) to make this Operator Manual available for consultation during all phases of operation. Refer to OSHA 2207 and/or applicable updated revisions which contains all OSHA job safety and health rules and regulations (1926 and 1910) covering construction.



CAUTION

The concept of portable, one and two man, hole digging equipment has been successfully utilized for many years as a practical solution to many types of hole digging job requirements. The basic concept is proven and well accepted within the associated marketplaces. Use of a Hole Digger requires strenuous

work activity. This type of work activity can be considered to be greater in magnitude than that experienced with the use of many other types of both light construction and lawn and garden related equipment. This type of work activity should only be attempted by operators of adequate physical size and stature, mental awareness and physical strength and condition. The body parts most noticeably affected during the hole digging process are the arms, hands, wrists, shoulders, lower back and legs. The process can also produce excessive stress/strain directly to the back muscles, spinal vertebrae and many other body parts. Back and wrist related pain can be side effects of utilizing a Hole Digger. A potential operator with a chronic back related problem or a history of back and/or other medically related problems should not attempt to utilize the Hole Digger. Use of the Hole Digger may only aggravate this and any other medically related problem. Because of the diverse type of prevailing job applications, job site conditions, operator experience levels and operator physical characteristics, no warranty, guarantee, representation and/or liability is made by the manufacturer as to the absolute correctness or sufficiency of any operational procedure, operational position and/or technique. There is no absolute guarantee that an operator of any given experience level, physical size and/or physical condition will be immune to the possibility of and/or probable physical side effects of the normal use of the Hole Digger. Each potential operator must be made aware of and assume the operational and physical liability described and/or associated with the use of the Hole Digger. Improper use of the Hole Digger can result in property damage and/or personal injury, including death. Each potential operator not willing to assume the operational and physical liability described and/or associated with the use of the Hole Digger, should not operate it. Proper levels of operator experience, skill and common sense are essential for maximizing the safe and efficient operation of the Hole Digger

Record the Hole Digger and engine/electric motor serial numbers in the spaces provided below.

_____ **Model Number**

_____ **Serial Number**

_____ **Electric Motor Serial Number**

_____ **Date of Purchase**

Specifications and design are subject to change without notice or obligation. All specifications are general in nature and are not intended for specific application purposes. General Equipment Company reserves the right to make changes in design, engineering or specifications and to add improvements or discontinue manufacture at any time without notice or obligation. General Equipment Company and its agents accept no responsibility for variations which may be evident in actual products, specifications, pictures and descriptions contained in this publication

Operator Instructional Data Sheet

The following undersigned operators of the Hole Digger described and/or pertaining to this Operator Manual have received formal safety and operational information/instruction from the undersigned owner(s)/instructor(s) in accordance to OSHA 29 CFR 1926.21 (b)(2) and/or applicable updated revisions pertaining to, but not necessarily limited to the:

1) READING, COMPREHENSION AND ACKNOWLEDGEMENT OF THE MATERIAL COMPRISING THE ENTIRE CONTENTS OF THE APPLICABLE OPERATOR MANUAL AND APPLICABLE SAFETY AND OPERATIONAL INFORMATION VIDEO TAPE FOR THE HOLE DIGGER.

2) FORMALIZED OPERATOR SAFETY PROGRAM TO BE DEvised BY THE OWNER OF THE HOLE DIGGER IN CONJUNCTION WITH THE CONTENTS OF THE APPLICABLE OPERATOR MANUAL AND THE SAFETY AND APPLICABLE OPERATIONAL INFORMATION VIDEO TAPE FOR THE HOLE DIGGER.

3) OSHA RULES AND REGULATIONS RESEARCHED FOR AND/OR BY THE OWNER OF THE HOLE DIGGER AND DEEMED APPLICABLE TO THE SAFE AND PROPER USE AND/OR OPERATION OF THE HOLE DIGGER FOR ANY SPECIFIC JOB APPLICATION.

4) LOCAL LAWS, REGULATIONS AND CUSTOMS RESEARCHED FOR AND/OR BY THE OWNER OF THE HOLE DIGGER AND DEEMED APPLICABLE TO THE SAFE AND PROPER USE AND/OR OPERATION OF THE HOLE DIGGER FOR ANY SPECIFIC JOB APPLICATION.

5) FORMALIZED MAINTENANCE PROGRAM FOR THE HOLE DIGGER TO BE DEvised BY THE OWNER OF THE HOLE DIGGER IN ACCORDANCE WITH, BUT NOT NECESSARILY LIMITED TO, THE SPECIFICATIONS, GUIDELINES AND OPERATIONAL INFORMATION CONTAINED IN THE APPLICABLE OPERATOR MANUAL.

6) COMPREHENSIVE OPERATIONAL INSTRUCTIONS FOR THE CORRECT AND PROPER USE OF THE HOLE DIGGER AS PER THE CONTENTS OF THE APPLICABLE OPERATOR MANUAL AND THE APPLICABLE SAFETY AND OPERATIONAL INFORMATION VIDEO TAPE.

_____ Operator _____ Owner/Instructor _____ Date

_____ Operator _____ Owner/Instructor _____ Date

_____ Operator _____ Owner/Instructor _____ Date

_____ Operator _____ Owner/Instructor _____ Date

_____ Operator _____ Owner/Instructor _____ Date

_____ Operator _____ Owner/Instructor _____ Date

NOTE: INSERT COPIES OF THIS PAGE WITHIN THE OPERATOR S MANUAL IF SPACE FOR ADDITIONAL OPERATORS IS REQUIRED.

Safety Precautions



DANGER

THE FOLLOWING SAFETY PRECAUTIONS PROVIDE SOME COMMON SENSE GUIDES TO PROMOTE SAFETY AND EFFICIENCY WITH THE 300 SERIES HOLE DIGGERS. NO WARRANTY, GUARANTEE OR REPRESENTATION IS MADE BY THE MANUFACTURER AS TO THE ABSOLUTE CORRECTNESS OR SUFFICIENCY OF ANY INFORMATION OR STATEMENT. THESE SAFETY PRECAUTIONS ARE INTENDED TO DEAL PRINCIPALLY WITH COMMON PRACTICES AND CONDITIONS ENCOUNTERED IN THE USE OF THE HOLE DIGGER AND ARE NOT INTENDED TO BE ALL INCLUSIVE. PROPER LEVELS OF OPERATOR EXPERIENCE, SKILL AND COMMON SENSE ARE ESSENTIAL FOR SAFE AND EFFICIENT OPERATION.



DANGER

THE ENGINE EXHAUST FROM THIS PRODUCT CONTAINS CHEMICALS KNOWN TO THE STATE OF CALIFORNIA TO CAUSE CANCER, BIRTH DEFECTS OR OTHER REPRODUCTIVE HARM. THIS STATEMENT IS MADE IN COMPLIANCE TO CALIFORNIA PROPOSITION 65.



DANGER

INCORRECT USE OF THE HOLE DIGGER CAN RESULT IN PROPERTY DAMAGE, PERSONAL INJURY OR EVEN DEATH. TO REDUCE THIS POSSIBILITY, GIVE COMPLETE AND UNDIVIDED ATTENTION TO THE JOB AT HAND AND FOLLOW THESE SAFETY PRECAUTIONS:

PREPARATION.

1) The 300 Series Hole Diggers are a specialized type of powered equipment, designed for a specific job function and requires adequate and thorough instruction BEFORE it is operated. The size, power, complexity and operating characteristics of this type of powered equipment would dictate that each operator must receive adequate, professional instruction regarding the proper operation of this Hole Digger before being allowed to utilize it. BEFORE attempting to utilize this Hole Digger, read this Operator's Manual, the

applicable Safety and Operational Information Video Tape and the material supplied by the engine manufacturer to familiarize each operator with its correct operating procedures. Avoid the urge not to take the necessary time to read this Operator's Manual before operating the Hole Digger. **DO NOT OPERATE THE HOLE DIGGER UNTIL EACH OPERATOR COMPLETELY COMPREHENDS THE CONTENTS OF THIS MANUAL, THE APPLICABLE SAFETY AND OPERATIONAL INFORMATION VIDEO TAPE, APPLICABLE SUPPLEMENTAL INFORMATION AND THE INFORMATION SUPPLIED BY THE ENGINE MANUFACTURER.**

2) Develop a comprehensive program for the safe operation of the Hole Digger by its owner(s) and/or operator(s). Such a program will include, but is not limited to: instructional requirements for operation, applicable OSHA requirements, local laws and regulations, job site safety and a Hole Digger maintenance program. Constantly examine and upgrade this program to guarantee owner(s) and/or operator(s) safety. Each operator must be fully instructed regarding the specifics of this safety program.

3) Determine that the Hole Digger is in its original, factory configuration and has not been modified in any manner. Many modifications can result in potentially dangerous configurations that can lead to property damage and/or personal injury. If there are any questions about possible modifications made to the Hole Digger, contact the Customer Service Department for specific information BEFORE utilization. There is no charge for this service.

4) Minors should never be allowed to operate the Hole Digger. Bystanders, especially children and animals, should not be allowed in the area where the Hole Digger is in use. The hole digging process can result in flying particles being emitted at high velocity and striking the operator and/or onlookers. This can lead to the possibility of property damage and/or personal injury. Keep all body parts, loose clothing, foreign objects and onlookers clear of the rotating auger and/or auger extensions.

5) Operators must be in proper physical condition, mental health and not under the influence of any substance (drugs, alcohol, etc.) which might impair vision, dexterity or judgment. Working with the Hole Digger is strenuous. If you have any condition that might be aggravated by strenuous work, check with your doctor BEFORE operating the Hole Digger. Guard against the possibility of back related injuries. Always lift the Hole Digger with leg muscles and not with the back. Operators must be of adequate height so that for any given operating configuration, the operator handle(s) remain below their shoulder sockets. Do not operate the Hole Digger if this condition is not satisfied. The 300

Series hole Diggers require that both operators be of similar height, weight and strength to maximize digging efficiency and minimize the possibility of personal injury. Both operators share the burden associated with the hole digging process.

6) Prolonged use of the Hole Digger (or other, similar machines) exposes the operator to vibrations which may produce Whitefinger Disease (Raynaud's Phenomenon). This phenomenon reduces the hand's ability to feel and regulate temperature, produces numbness and burning sensations and may cause nerve and circulation damage and tissue necrosis. Antivibration systems do not guarantee that you will not sustain Whitefinger Disease. Therefore, continuous and regular users should closely monitor the condition of their hands and fingers. After each period of use, exercise to restore normal blood circulation. If any of the symptoms appear, seek medical advice immediately.

7) Clothing must be sturdy and snug fitting, but allow complete freedom of movement. Never wear loose fitting jackets, scarves, neckties, jewelry, flared or cuffed pants or anything that could become caught on controls or moving parts. Wear long pants to protect your legs. Protect your hands with heavy duty, nonslip gloves to improve your grip. Good footing is most important when operating the Hole Digger. Wear sturdy boots with nonslip soles. Steel-toed safety shoes are highly recommended. Keep shoes properly laced. Never wear tennis shoes or other, similar type shoes which afford little or no protection. Wear an approved safety hard hat to protect the operator(s) head(s) where there is a danger of head injuries. Noise, generated by the engine of the Hole Digger and the actual process itself, can damage your hearing. Wear approved sound barriers (ear plugs or ear muffs) to protect your hearing. Continuous and regular operators should have their hearing checked regularly.

8) Visually inspect the Hole Digger, auger(s), auger extension(s), and accessories for damaged or worn parts. Inspect each auger for the proper screw bit and teeth. Look for loose and/or damaged handle grips. Check for loose and/or broken parts. Determine that operator controls work freely, all safety devices are operative and information/safety decals are readable. Check to determine that the Hole Digger and all related accessories are in good mechanical condition BEFORE utilization.

9) Contact appropriate representatives to determine if/where electrical cables, gas lines and other hazardous items are buried under the work surface BEFORE utilization. Some Hole Diggers feature operator handles constructed of a non metallic, composite material. Use of this material does not guarantee the operators will be properly insulated from contact with charged electrical cables. The Hole Digger

and related accessories are not classified as being insulated. Contact with buried electrical cables, gas lines and other hazardous items can result in electrocution and/or an explosion.

10) Know how the controls operate. Know how to stop the engine quickly in an emergency. Always start the engine according to the instructions as outlined in this manual to minimize the possibility of unexpected or uncontrolled auger rotation. Unexpected auger rotation can cause loss of machine control, and the possibility of property damage and/or personal injury.

11) Never exceed the recommended capacities of the Hole Digger. Refer to the **Specifications** section of this manual for more detailed information. Always utilize the correct auger and auger extension series designed for use with the Hole Digger. Some Hole Diggers can utilize specially designed augers intended for drilling holes through ice. Such an auger will find limited success when utilized to dig earth. Earth augers are not designed to drill through ice. Use of an incorrect auger or auger series can result in property damage and/or personal injury.

12) The 300 Series Hole Digger are powered by gasoline engine which produce Carbon Monoxide fumes during the combustion process. Carbon Monoxide fumes are poisonous. Breathing Carbon Monoxide fumes while operating the Hole Digger can result in property damage and/or personal injury. The normal operation of the Hole Digger is outdoors where the potential effects of Carbon Monoxide to the operators are minimized. If the Hole Digger is operated in a closed area (indoors or outdoors), determine if supplemental ventilation is required to minimize the potential effects of Carbon Monoxide to the operators. Follow all current OSHA regulations pertaining to ventilation.

OPERATION.

1) Give complete and undivided attention to the job at hand. Do not chew gum, smoke and/or use smokeless tobacco while utilizing the Hole Digger. Do not attempt to eat and/or drink while utilizing the Hole Digger. Determine that eyeglasses, hearing aid devices and other medical related devices are properly secured. Keep shoes properly laced. Use of the Hole Digger is strenuous and causes fatigue. Help prevent the cause of an accident. Plan to take work breaks as required to help maintain proper mental and physical alertness.

2) The 300 Series Hole Diggers are not sealed or insulated. Do not operate any Hole Digger in an explosive atmosphere or near combustible materials. Refer to current OSHA rules and regulations.

3) Gasoline is an extremely flammable fuel. Use extreme caution when handling gasoline or mixing

fuel. Always utilize UL®, CSA® OR CE approved containers for the storage and transportation of fuel. Do not smoke or bring fire or flame near the fuel. Always shut off the engine and allow it to cool before refueling. Never remove the fuel tank filler cap while the engine is running. Never operate an engine without a fuel tank filler cap. Select bare ground for fueling and move at least 10 feet from the fueling spot before starting the engine. Wipe off any spilled fuel before starting the engine and check for leakage. If a fuel or oil leak is found, do not start or run the engine until the leak is fixed and the spillage has been wiped away. Take care not to get fuel or oil on your clothing. If this happens, change your clothing immediately. Before operating the Hole Digger refer to the **Specifications** section of this manual for more detailed information regarding fuel and lubrication requirements.

4) The 300 Series Hole Diggers are designed for use by two operators. Use of the Hole Digger by one or more than two operators can lead to confusion and loss of control, resulting in property damage and/or personal injury. Never operate the Hole Digger with an improper number of operators. Such a configuration can result in property damage and/or personal injury. If it is felt that more than two persons are required to furnish additional "down pressure" to the auger, STOP and contact the Customer Service Department for specific operational and service/maintenance information. There is no charge for this service.

5) Do not operate the Hole Digger with onlookers close by. Caution all onlookers to stand clear. The hole digging process can result in flying particles being emitted at high velocity and striking the operator and/or onlookers. This can lead to the possibility of property damage and/or personal injury. Keep all body parts, loose clothing and foreign objects clear of the rotating auger.

6) Do not utilize a shovel and/or foreign object to remove loose soil from around the hole area while the Hole Digger is in use. Such a practice can result in the shovel and/or foreign object to become entrapped by the rotating auger, leading to property damage and/or personal injury.

7) Start the engine according to the instructions as outlined in this manual to minimize the possibility of unexpected auger rotation. Unexpected auger rotation can result in the loss of machine control and the possibility of property damage and/or personal injury.

8) Start and operate the Hole Digger only in a well ventilated area. Carbon Monoxide fumes given off by an engine are poisonous. Breathing these fumes can result in property damage and/or personal injury. Operate the Hole Digger only when/where visibility and light are adequate for the job at hand. Work carefully.

Always hold the operator handles firmly with both hands. Wrap your fingers around the handles, keeping them cradled between your thumbs and fingers. Always determine the operator handles are in good condition and free of moisture, pitch, oil or grease. Wear gloves to improve your grip. Never leave the Hole Digger running unattended.

9) Stop the engine between each hole. Allowing the engine to remain operating between each hole substantially increases the potential for property damage and/or personal injury. Special care must be exercised on slippery conditions and on difficult, uneven surfaces. Watch for cracks, high spots and other, surface irregularities. Keep proper footing and balance at all times. The normal use of this machine is on level surfaces. Other terrains can be dangerous and should be avoided. Only properly trained operators should attempt these techniques.

10) The 300 Series Hole Diggers are designed to be started by both operators in the following manner: the Crew Chief regulates engine speed (RPM) with the engine throttle control while the Crew Member starts the engine by use of the recoil starter. The Crew Chief is responsible for the necessary verbal commands. Never operate a 300 Series Hole Digger if it requires one of the operators to operate the engine throttle control, carburetor choke system and the engine recoil starter (or any combination) at the same time. This is not a factory designed operating configuration for the Hole Digger. Such configuration(s) will result in loss of machine control, property damage and personal injury. Contact the Customer Service Department for information relative to restoring the Hole Digger to its original configuration BEFORE further utilization. There is no charge for this service.

11) Contact with a hot, engine muffler can cause property damage and/or personal injury. Remain clear of a hot engine muffler. Do not over speed the engine by altering the governor setting or by disconnecting the engine governor. Serious damage to the engine and/or personal injury can result.

12) The 300 Series Hole Digger are powered by gasoline engines which produce Carbon Monoxide fumes during the combustion process. Carbon Monoxide fumes are poisonous. Breathing Carbon Monoxide fumes while operating the Hole Digger can result in property damage and/or personal injury. The normal operation of the Hole Digger is outdoors where the potential effects of Carbon Monoxide to the operators are minimized. If the Hole Digger is operated in a closed area (indoors or outdoors), determine if supplemental ventilation is required to minimize the potential effects of Carbon Monoxide to the operators. Follow all current OSHA regulations pertaining to ventilation.

13) Because this Hole Digger is classified as a low

cost, hand held, low horsepower, portable type machine, it is limited in the number of practical and/or suitable job applications. A particular job site, actual surface conditions, job specifications and operator skill/common sense may dictate that a different type of machine (with characteristics of higher purchase cost, being mounted to a carrier vehicle, with greater horsepower and less mobility), method and/or process be utilized to properly complete the job with the degree of efficiency and safety required. Contact the Customer Service Department for specific information regarding suitable job applications, job site surface conditions and operator experience/skill/common sense recommendations for the Hole Digger BEFORE utilization. There is no charge for this service.

MAINTENANCE, REPAIR AND STORAGE.

1) Use only genuine, approved replacement parts and accessories for maintenance and repair. Use of parts and accessories manufactured by others can result in property damage and/or personal injury.

2) Follow the Service instructions as outlined in the appropriate section of this manual.

3) Always stop the engine and disconnect the spark plug wire BEFORE checking or working on the Hole Digger.

4) Always properly maintain the Hole Digger. Frequently check all fasteners and individual parts. Built in safety features are effective only if they are maintained in good working condition. Replace any questionable part or assembly with a genuine, factory approved, replacement part. Do not forsake proper maintenance for the price of a few replacement parts. Proper maintenance does not cost...it actually pays dividends. Do not attempt any maintenance repair work not described in this manual. Have such work performed at your dealer's service facility.

5) Determine the engine throttle control and throttle cable assemblies are not damaged and allow for complete freedom of movement. This is necessary to allow them to perform their intended job functions. Do not operate the Hole Digger with a damaged engine throttle control and/or throttle cable assembly.

6) A worn or damaged engine muffler is a fire hazard and may cause loss of hearing. Check to see that the muffler is in good condition. If the muffler is equipped with a spark arresting device, determine that it is in proper working condition at regular service intervals. Replace the spark arresting device with an approved replacement if there is any question of its integrity. It is the responsibility of the owner(s) and/or operator(s) to provide for and properly maintain a USDA approved, spark arresting muffler in an operating area specified by law. Check with appropriate governing agencies for more specific information. The Hole Digger must not be

operated if the muffler is faulty or has been removed. Contact with a hot engine muffler can cause property damage and/or personal injury.

7) Maintain all safety and operation decals in proper condition. If any decal becomes damaged and/or unreadable, replace with a genuine, factory approved, replacement part only.

8) The Hole Digger may utilize self locking type hexagon head nuts to minimize the effects of vibration. Replace all self locking hardware with genuine, factory approved, replacement parts only.

9) Consult the material supplied by the engine manufacturer for specific information relative to proper operational, lubrication and storage requirements.

10) Replace the auger teeth and screw bit when signs of excessive wear are seen. When such components are not replaced at proper intervals, excessive wear will occur at the boring head and auger flighting. The end result is an inverted cone configuration for the auger which usually requires complete replacement. FIGURE 1. Digging with augers that are past their useful service life or that have not been properly maintained can result in substandard productivity, excessive property damage and/or personal injury. Auger service life can be greatly extended with a consistent auger maintenance program.



FIGURE 1

Assembly

Open the shipping carton immediately upon receipt. Visually inspect the contents of the carton for freight damage and/or missing parts. If shipping damage is evident, contact the delivering carrier immediately to arrange for an inspection of the damage by their claims representative. Federal law requires that a claim be filed within a specified time period. If missing parts are detected, notify your dealer or contact the Customer Service Department for assistance in obtaining them.

Included in the shipment for all models of Hole Diggers should be the following:

- 1 each, engine/transmission assembly
- 3 each, straight operator handles with handle grips
- 1 each, straight operator handle with throttle control assembly
- 1 each, bag of assorted hardware
- 1 each, Operator Manual
- 1 each, Safety and Operational Information Video Tape
- 1 each, applicable engine manual
- 1 each, warranty initiation card
- 1 each, Final Inspection Form

INSTALLING THE COMPOSITE MATERIAL OPERATOR HANDLES.

APPLICATION: MODELS 310F, 342F AND 356F HOLE DIGGERS POWERED BY THE SUBARU EC10 SERIES 2 CYCLE ENGINE ONLY.

Tools Required:

- 2 each, 1/2 inch wrenches
- 1 each, torque wrench, 240 inch pounds (27 N.m.) capacity with 1/2 inch socket
- 1 each, small, flat bladed screwdriver
- 1 each, small, vice grip pliers
- 1 each, cut off pliers

The assembly of the operator handles to the transmission will require a level working platform of sufficient size and appropriate height. As an alternative, the transmission shaft assembly can be securely mounted in a suitable bench vise.

- 1) Open the bag of assorted hardware into a suitable container in order to minimize the possibility of losing any part.
- 2) Assemble the steel handle reinforcements over the handles and align the holes so that the retaining capscrews can be readily inserted. The reinforcement with the welded throttle cable guide is assembled to the throttle control handle. FIGURE 2.

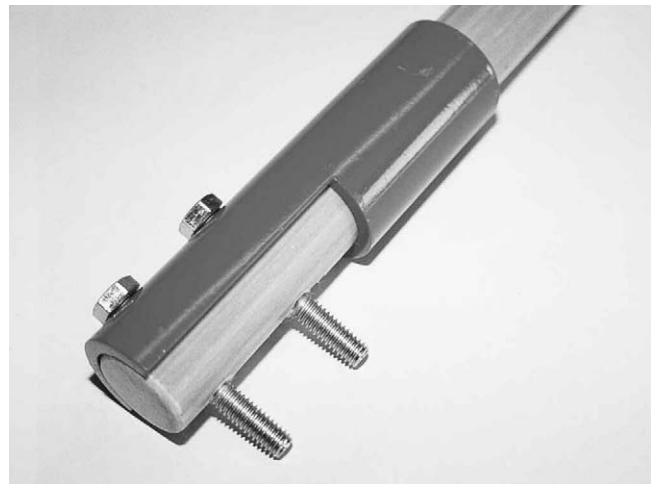

FIGURE 2

- 3) Facing the spark plug end of the engine, install two straight operator handles into the transmission case sockets with the supplied cap screws facing upwards. FINGER TIGHTEN ONLY. DO NOT FINAL TORQUE THE FASTENERS AT THIS TIME. FIGURE 3.



FIGURE 3

- 4) Facing the fuel tank end of the engine, install the remaining straight operator handle into the transmission case socket located under the fuel tank ON/OFF valve as per Step 3. FINGER TIGHTEN ONLY. Install the operator handle with the throttle control assembly in the remaining transmission case socket with the aluminum nameplate facing upwards. The Hole Digger is designed for the Magura® twist grip throttle control to be operated by the right hand. All operating instructions in this Operator's Manual are directed with the Magura® throttle control to be assembled and operated in the configuration as outlined in the **Assembly** section.

Do not deviate the assembly and operation of the Magura® throttle control from that outlined in the Operator's Manual. FIGURE 4.

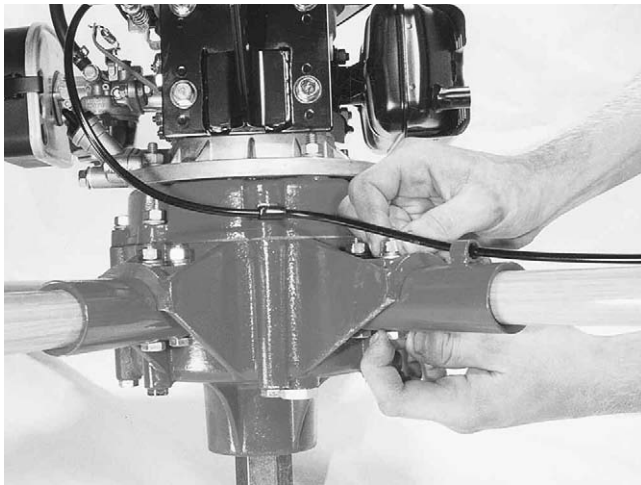

FIGURE 4



DANGER

IMPROPER ASSEMBLY AND OPERATION OF THE MAGURA® THROTTLE CONTROL WILL REDUCE THE CONTROLLABILITY OF THE HOLE DIGGER, RESULTING IN PROPERTY DAMAGE AND/OR PERSONAL INJURY.

5) Using the torque wrench, torque all handle cap screws evenly to 240 inch pounds (27 N.m.).



CAUTION

Excessive fastener torque values can lead to subsurface fractures in the material and to premature failure of the handle. Frequently check the handle attach areas for signs of cracking and fatigue. Replace any operator handle of questionable structural qualities with a factory replacement part only.

6) Route the throttle cable assembly into the guide located on the handle reinforcement and into the throttle cable adjustment fitting located on the engine block. FIGURE 5



FIGURE 5

7) Route the throttle cable inner wire through the throttle return spring provided by Subaru. Position the spring between the throttle control lever and the cable adjustment fitting. Route the inner wire through the small hole located on the throttle control lever of the carburetor. Slide the inner wire through the swivel assembly. FIGURE 6.

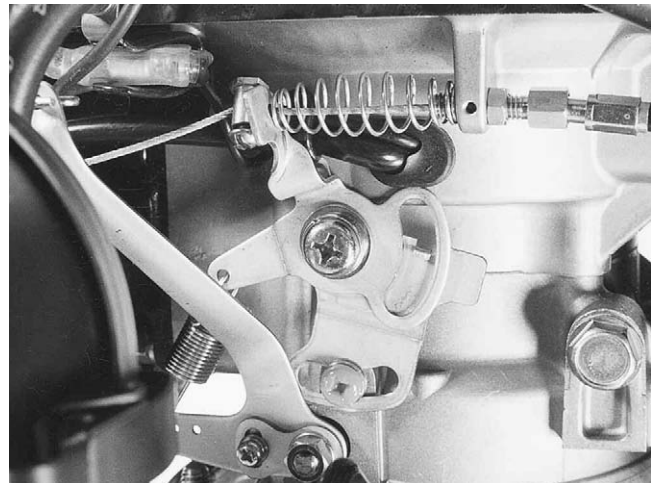

FIGURE 6

7) Secure the throttle cable to the cap screw located directly under the engine fuel tank with the supplied clamp. Do not allow the clamp to crush the throttle cable. FIGURE 7

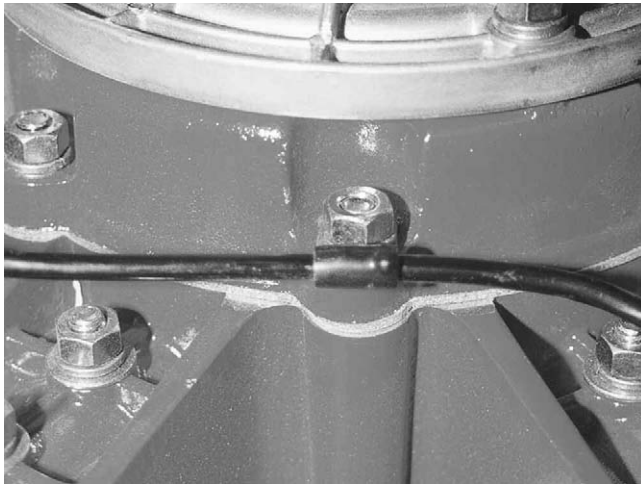

FIGURE 7

9) Route the remaining inner wire past the carburetor toward the spark plug. Place the throttle control lever in the idle speed position. Using the vice grip pliers, pull directly on the inner wire to remove ONLY any excess slack. The pulling movement must not rotate the Magura® throttle control. FIGURE 8 .

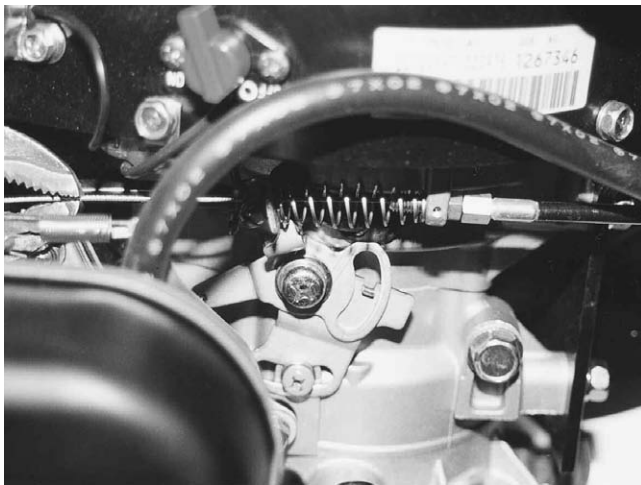

FIGURE 8

DANGER

FOR OPERATIONAL SAFETY AND OVERALL PRODUCTIVITY CONSIDERATIONS, IT IS EXTREMELY IMPORTANT THAT INNER WIRE SLACK BE COMPLETELY REMOVED FROM THE THROTTLE CONTROL SYSTEM. INNER WIRE SLACK CAN REDUCE OVERALL OPERATOR CONTROL, RESULTING IN PROPERTY DAMAGE AND/OR PERSONAL INJURY.

10) Tighten the swivel assembly against the inner wire. The swivel assembly must be held tight against the throttle arm with no slack allowed. Rotate the throttle control several times to check for complete freedom of movement. The return spring is designed to rapidly return the engine to idle speed when the throttle control is released. If this is not occurring, check the throttle control assembly for possible causes of binding and movement restrictions. Adjust the swivel assembly and throttle cable adjusting fitting as necessary to allow for complete freedom of movement. FIGURE 9.



FIGURE 9

11) Rotate the throttle control counterclockwise (the maximum speed position) to determine that the inner wire pulls the throttle control lever of the carburetor forward, against its stop. Improper adjustment will not allow the engine to operate at its maximum, no load, governed speed of 4700 RPM and affect the overall digging performance of the Hole Digger. Adjust the swivel assembly and throttle cable adjusting fitting as necessary to allow for complete freedom of movement. Check for possible throttle cable inner wire binding and movement restrictions caused by the handle reinforcement and clamp. Rework and adjust as necessary to allow for complete freedom of movement. FIGURE 10.

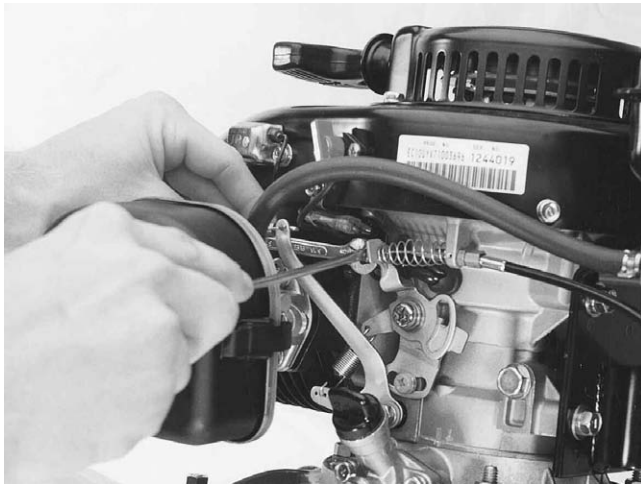

FIGURE 10

11) Using the cut off pliers, cut off the remaining inner wire behind the screw nipple, leaving approximately one inch (25.4 mm) of excess wire.

12) Check all fasteners for security. Consult a fastener torque chart for the proper torque value if any fastener is found to require retorquing.

INSTALLING THE COMPOSITE MATERIAL OPERATOR HANDLES.

APPLICATION: MODELS 330B, 343B AND 357B HOLE DIGGERS POWERED BY THE BRIGGS & STRATTON 133702 SERIES 4 CYCLE ENGINE ONLY.

Tools Required:

- 2 each, 1/2 inch wrenches
- 1 each, torque wrench, 240 inch pounds (27N.m.) capacity with 1/2 inch socket
- 1 each, small, flat bladed screwdriver
- 1 each, small, vice grip pliers
- 1 each, cut off pliers

The assembly of the operator handles to the transmission will require a level working platform of sufficient size and appropriate height. As an alternative, the transmission shaft assembly can be securely mounted in a suitable bench vise.

1) Open the bag of assorted hardware unto a suitable container in order to minimize the possibility of losing any part.

2) Assemble the steel handle reinforcements over the handles and align the holes so that the retaining capscrews can be readily inserted. The reinforcement with the welded throttle cable guide is assembled to the throttle control handle. FIGURE 11

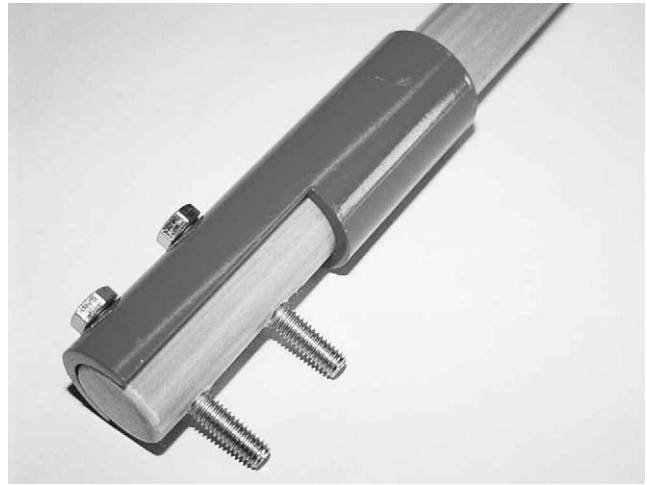

FIGURE 11

3) Facing the spark plug side of the engine, install the two straight operator handles into the transmission case sockets with the supplied capscrews facing upwards. FINGER TIGHTEN ONLY. DO NOT FINAL TORQUE THE FASTENERS AT THIS TIME. FIGURE 12.

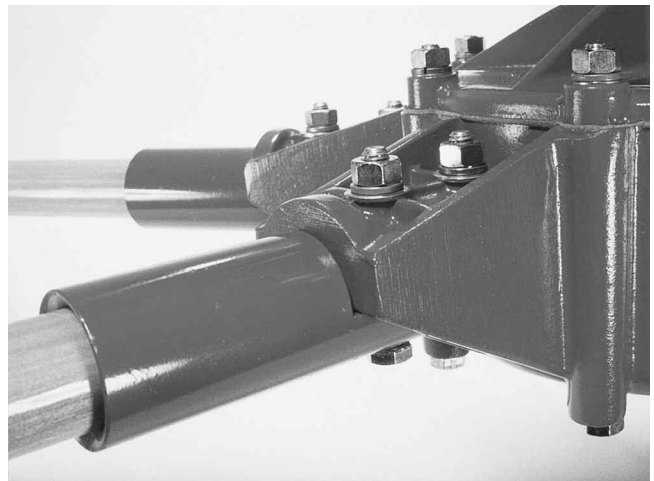

FIGURE 12

4) Facing the fuel tank side of the engine, install the remaining straight operator handle into the transmission case socket on the left side as per Step 3. FINGER TIGHTEN ONLY. Install the operator handle with the throttle control assembly in the remaining transmission case socket located under the fuel tank ON/OFF valve with the aluminum nameplate facing upwards. The Hole Digger is designed for the Magura® twist grip throttle control to be operated by the right hand. All operating instructions in this Operator's Manual are directed with the Magura® throttle control to be assembled and operated in the configuration as outlined in the

Assembly section. Do not deviate the assembly and operation of the Magura® throttle control from that outlined in the Operator's Manual. FIGURE 13.

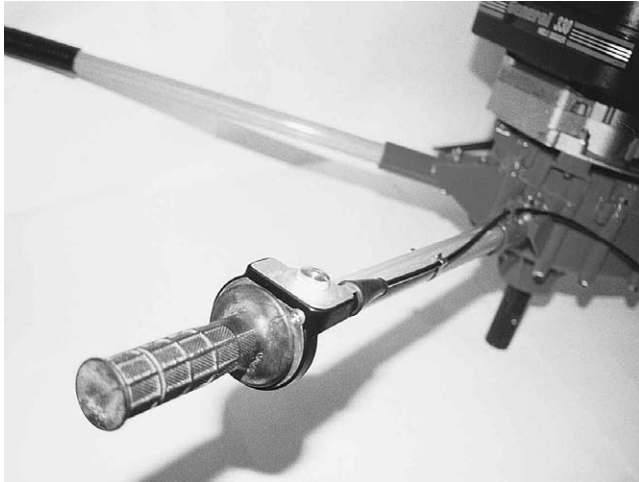

FIGURE 13

DANGER

IMPROPER ASSEMBLY AND OPERATION OF THE MAGURA® THROTTLE CONTROL WILL REDUCE THE CONTROLLABILITY OF THE HOLE DIGGER, RESULTING IN PROPERTY DAMAGE AND/OR PERSONAL INJURY.

5) Using the torque wrench, torque all handle cap screws evenly to 240 inch pounds (27N.m.).

CAUTION

Excessive fastener torque values can lead to subsurface fractures in the material and to premature failure of the handle. Frequently check the handle attach areas for signs of cracking and fatigue. Replace any operator handle of questionable structural qualities with a factory replacement part only.

6) Route the throttle cable assembly into the guide located on the handle reinforcement and into the attach bracket located near the air cleaner assembly. The attach bracket should be in full contact with the aluminum end of the throttle cable. Use the Phillips screwdriver to only temporarily secure. **DO NOT FINAL TORQUE THE FASTENER AT THIS TIME.** FIGURE 14.



FIGURE 14

7) Using the flat bladed screwdriver, remove the short length of wire from the swivel assembly located in the carburetor throttle arm. Route the inner wire of the throttle cable into the hole of the swivel assembly. The small flat washer must be located between the inner wire and the throttle arm to minimize friction and extend the service life of all components. FIGURE 15.



FIGURE 15

8) Determine that the carburetor throttle arm is in the ignition cut-off position with the metal blade in direct contact with the ignition switch mechanism. Using the vice grip pliers, remove any excess inner wire slack and tighten the swivel assembly screw using the flat bladed screwdriver and 5/16 inch wrench. The pulling movement with the vice grip pliers must not rotate the Magura® throttle control. Release the inner wire and allow the carburetor throttle arm to move back to its original position. The throttle arm return spring is designed to rapidly return the engine to the idle speed/ignition cut off position when the throttle control

is released. If this is not occurring, check the throttle control assembly for possible causes of binding and movement restrictions. Adjust the swivel assembly as necessary to allow for complete freedom of movement. FIGURE 16.

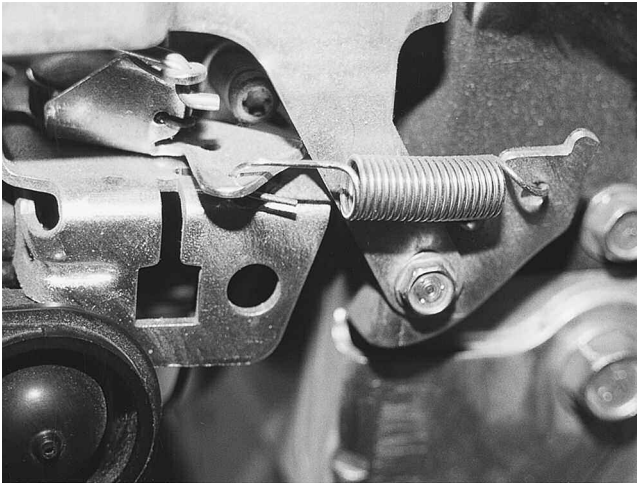

FIGURE 16

DANGER

FOR OPERATIONAL SAFETY AND OVERALL PRODUCTIVITY CONSIDERATIONS, IT IS EXTREMELY IMPORTANT THAT INNER WIRE SLACK BE COMPLETELY REMOVED FROM THE THROTTLE CONTROL SYSTEM. INNER WIRE SLACK CAN REDUCE OVERALL OPERATOR CONTROL, RESULTING IN PROPERTY DAMAGE AND/OR PERSONAL INJURY.

9) Determine that the carburetor throttle arm is in the ignition cut-off position. Using the screwdriver, loosen the attach bracket screw enough to allow the outer jacket of the throttle cable to be pushed backwards toward the Magura® throttle control and remove any excess slack. Tighten the attach bracket screw firmly. FIGURE 17.

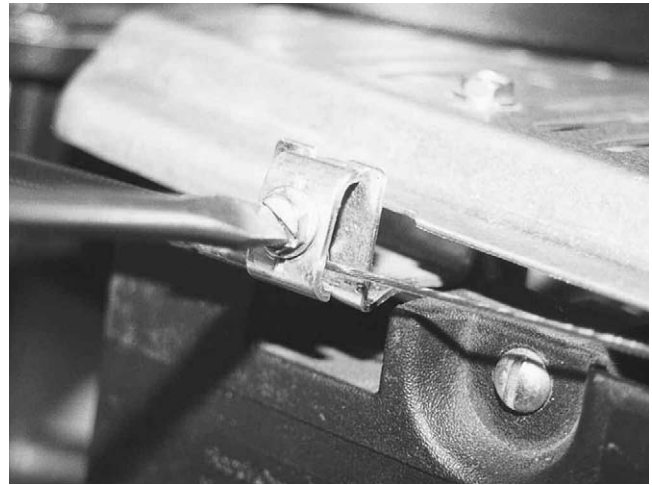

FIGURE 17

10) Rotate the throttle control several times to check for possible throttle cable inner wire binding and movement restrictions caused by the bracket and clamp. The supplemental extension spring attached to the carburetor throttle arm is provided by General Equipment Company. It is intended to allow the carburetor throttle arm to fully engage the ignition cut-off switch when the throttle control is released. If this is not occurring, check the throttle control assembly for possible causes of binding and movement restrictions. Adjust the throttle cable inner wire as necessary to allow for complete freedom of movement. FIGURE 18.



FIGURE 18

DANGER

THE HOLE DIGGER MUST NOT BE OPERATED WITHOUT THE SUPPLEMENTAL EXTENSION SPRING SUPPLIED BY GENERAL EQUIPMENT COMPANY. BEFORE UTILIZING THE HOLE DIGGER DETERMINE THAT THE STRUCTURAL INTEGRITY OF THE SUPPLEMENTAL SPRING WILL ALLOW IT TO PERFORM ITS INTENDED FUNCTION. REPLACE THE SUPPLEMENTAL SPRING AS NECESSARY WITH A FACTORY REPLACEMENT ONLY.

Improper adjustment will not allow the engine to operate at its maximum, no load, governed speed and affect the overall digging performance of the Hole Digger.

11) Rotate the throttle control counterclockwise (the maximum speed position) to determine that the inner wire pulls the throttle arm to its maximum speed position. Improper adjustment will not allow the engine to operate at its maximum, no load, governed speed of 4000 RPM.

12) Using the cut off pliers, cut off the remaining inner wire behind the screw nipple, leaving approximately one inch (25.4 mm) of excess wire.

13) Check all fasteners for security. Consult a fastener torque chart for the proper value if any fastener is found to require retorquing.

INSTALLING THE COMPOSITE MATERIAL OPERATOR HANDLES.

APPLICATIONS: MODELS 330H, 343H AND 357H POWERED BY THE HONDA GXV140 4 CYCLE GASOLINE ENGINE ONLY.

Tools Required:

- 2 each, 1/2 inch wrenches
- 1 each, 5/16 inch wrench
- 1 each, torque wrench, 240 inch pounds capacity with 1/2 inch socket
- 1 each, small flat bladed screw driver
- 1 each, small Phillips screwdriver
- 1 each, small vice grip pliers
- 1 each, cut off pliers

The assembly of the operator handles to the transmission will require a level working platform of sufficient size and appropriate height. As an alternative, the transmission shaft assembly can be securely mounted in a suitable bench vice.

1) Open the bag of assorted hardware into a suitable

container in order to minimize the possibility of losing any part.

2) Assemble the steel handle reinforcements over the handles and align the holes so that the retaining capscrews can be readily inserted. The reinforcement with the welded throttle cable guide is assembled to the throttle control handle. FIGURE 19.

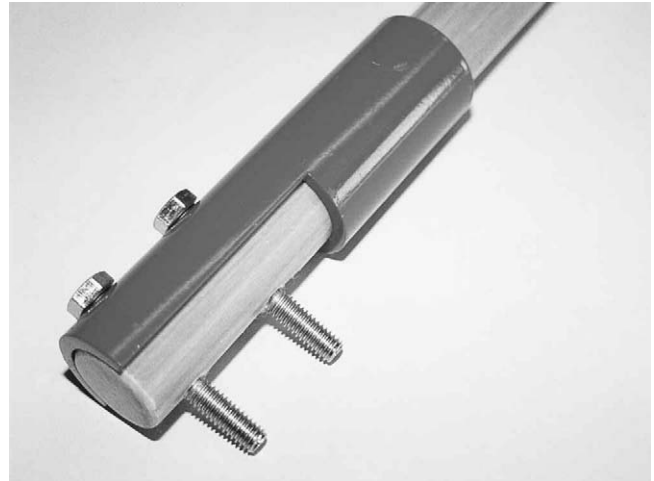

FIGURE 19

3) Facing the spark plug end of the engine, install two straight operator handles into the transmission case sockets with the supplied cap screws facing upwards. FINGER TIGHTEN ONLY. DO NOT FINAL TORQUE THE FASTENERS AT THIS TIME. FIGURE 20.

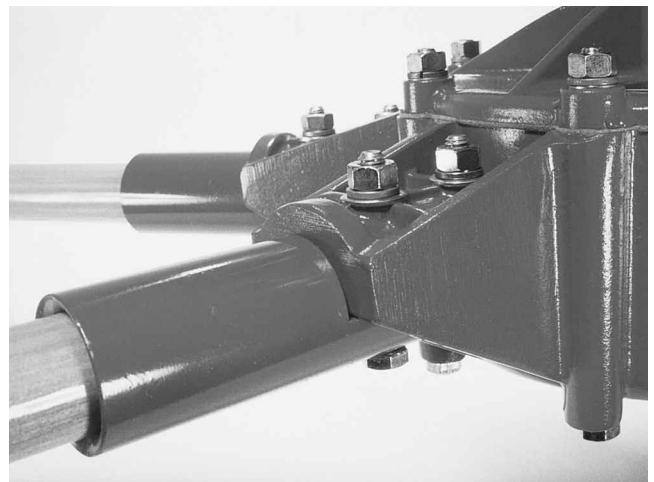

FIGURE 20

4) Facing the fuel tank end of the engine, install the

remaining straight operator handle into the transmission case socket located under the engine governor control as per Step 3. **FINGER TIGHTEN ONLY.** Install the operator handle with the throttle control assembly in the remaining transmission case socket with the aluminum nameplate facing upwards. The Hole Digger is designed for the Magura® twist grip throttle control to be operated by the right hand. All operating instructions in this Operator's Manual are directed with the Magura throttle control to be assembled and operated in the configuration as outlined in the Assembly section. Do not deviate the assembly and operation of the Magura® throttle control from that outlined in the Operator's Manual. FIGURE 21.

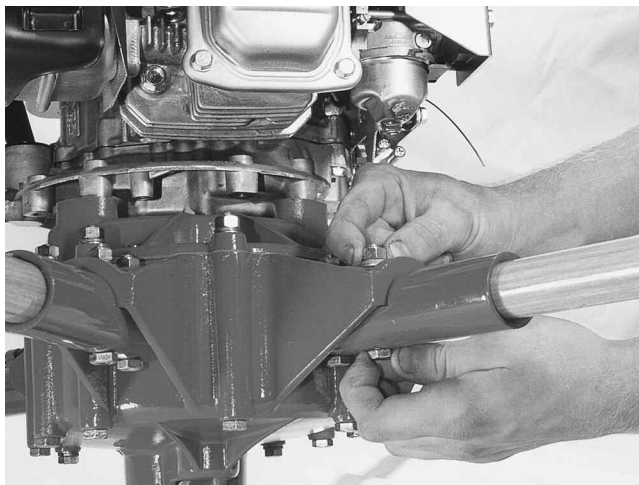

FIGURE 21



DANGER

IMPROPER ASSEMBLY AND OPERATION OF THE MAGURA® THROTTLE CONTROL WILL REDUCE THE CONTROLLABILITY OF THE HOLE DIGGER, RESULTING IN PROPERTY DAMAGE AND/OR PERSONAL INJURY.

5) Using the torque wrench, torque all handle capscrews evenly to 240 inch pounds (27 N.m.).



CAUTION

Excessive fastener torque values can lead to subsurface fractures in the material and to premature failure of the handle. Frequently check the handle attach areas for signs of cracking and fatigue. Replace any operator handle of questionable structural qualities with a factory replacement part only.

6) Route the throttle cable assembly into the guide

located on the handle reinforcement and into the throttle cable attach bracket located on the engine block under the air cleaner. The attach bracket has two locations through which to route the cable. Route the cable through the upper location. The attach bracket should be in full contact with the aluminum end of the throttle cable. Use the Phillips screw driver to temporarily secure. FIGURE 22.

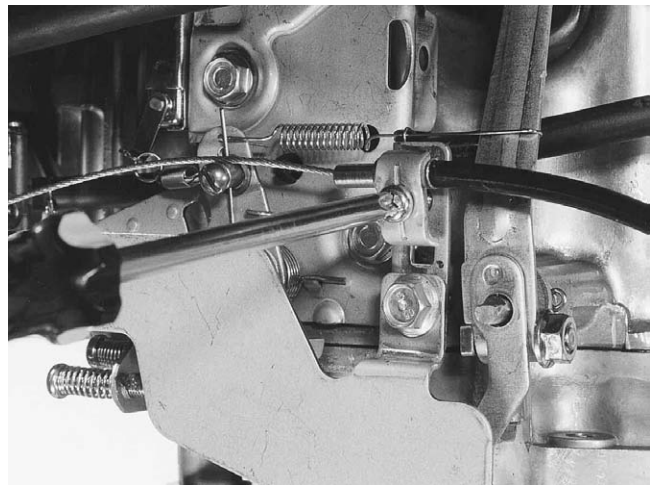

FIGURE 22

7) Using the flat bladed screwdriver, remove the short length of wire from the swivel assembly located in the carburetor throttle arm. Route the inner wire into the hole of the swivel assembly. The small flat washer must be located between the inner wire and the throttle arm to minimize friction and extend the service life of all components. FIGURE 23.

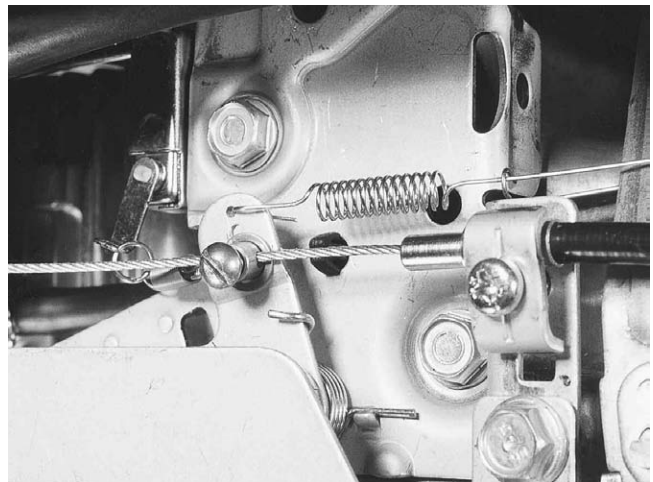

FIGURE 23.

8) Secure the throttle cable to the transmission cap

screw under the fuel tank with the supplied clamp. Do not allow the clamp to crush the throttle cable. FIGURE 24.



FIGURE 24

9) Using the vice grip type pliers, remove any excess inner wire slack and tighten the swivel assembly screw using the flat bladed screwdriver and 5/16 inch wrench. The pulling movement with the vice grip type pliers must not rotate the magura® throttle control. The throttle arm return spring is designed to rapidly return the engine to idle speed/ignition cut off when the throttle control is released. If this is not occurring, check the throttle control assembly for possible causes of binding and movement restrictions. Adjust the swivel assembly as necessary to allow for complete freedom of movement. FIGURE 25.

DANGER

FOR OPERATIONAL SAFETY AND PRODUCTIVITY CONSIDERATIONS, IT IS EXTREMELY IMPORTANT THAT INNER WIRE SLACK BE COMPLETELY REMOVED FROM THE THROTTLE CONTROL SYSTEM. INNER WIRE SLACK CAN REDUCE OVERALL OPERATOR CONTROL, RESULTING IN PROPERTY DAMAGE AND/OR PERSONAL INJURY.

10) Rotate the throttle control counterclockwise (the maximum speed position) to determine that the inner wire pulls the throttle lever of the carburetor forward, against its stop. Improper adjustment will not allow the engine to operate at its maximum, no load, governed speed and affect the overall digging performance of the Hole Digger. Adjust the swivel assembly and throttle cable attach bracket as necessary to allow for

complete freedom of movement.

Check for possible throttle cable inner wire binding and movement restrictions caused by the clip and clamp. Rework and adjust as necessary to allow for complete freedom of movement.

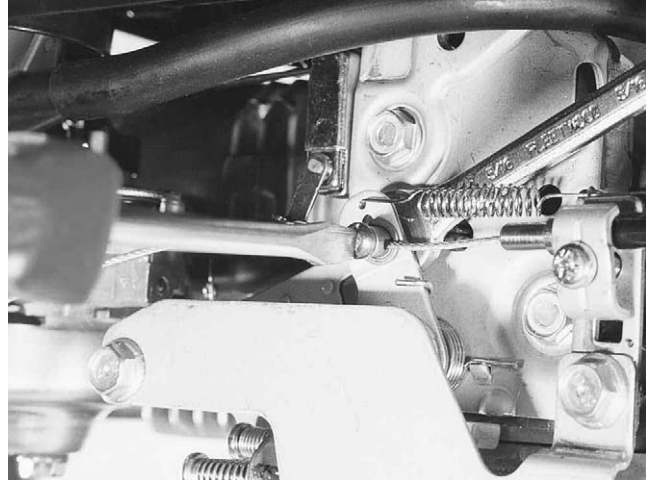

FIGURE 25

11) Using the cut off pliers, cut the remaining inner wire behind the swivel assembly, leaving approximately one inch (25.4 mm) of excess wire.

12) Check all fasteners for security. Consult a fastener torque chart for proper torque value if any fastener is found to require retorquing.

NOTES TO THE THROTTLE CABLE INSTALLATION.

APPLICATION: MODELS 330H, 343H AND 357H HOLE DIGGERS POWERED BY THE HONDA GXV140 4 CYCLE GASOLINE ENGINE ONLY.

1) The Honda GXV140 engine incorporates a multipurposed carburetor/throttle arm design that allows it to be utilized with both Bowden (push) and braided wire (pull) type configurations. For simplicity, productivity and service reasons, the Hole Digger incorporates a braided wire (pull) type configuration. A magura® twist grip throttle control is utilized as the engine speed control device. The Magura® throttle control has proven to be a rugged, dependable device that delivers exceptional service while requiring only minimal service.

2) The GXV140 engine utilizes one or two spring loaded screws as stops for the carburetor throttle arm.

a) If equipped, the shorter (inner) screw is non functional for this application.

b) The longer (outer) screw is factory set to prevent the engine from operating in an overspeed configuration. As set at the factory, the GXV140 engine will operate at approximately 3800/3900 RPM no load. In a no load configuration the engine is operating at maximum governed speed without an earth auger attached to the transmission driveshaft.



CAUTION

Do not alter the position of the spring loaded screw that regulates maximum engine speed. An improper setting can result in excessive engine speed leading to damage, substandard digging performance and loss of operator control that can result in property damage and/or personal injury.

3) The GXV140 engine may utilize a forced idle type governor spring to provide the proper engine idle speed. With the spring system in proper operation, the engine will normally idle at 1500/1600 RPM. An improper spring system or use of an applicable engine without the spring properly attached will not allow the engine to operate at the specified idle speed. FIGURE 26.

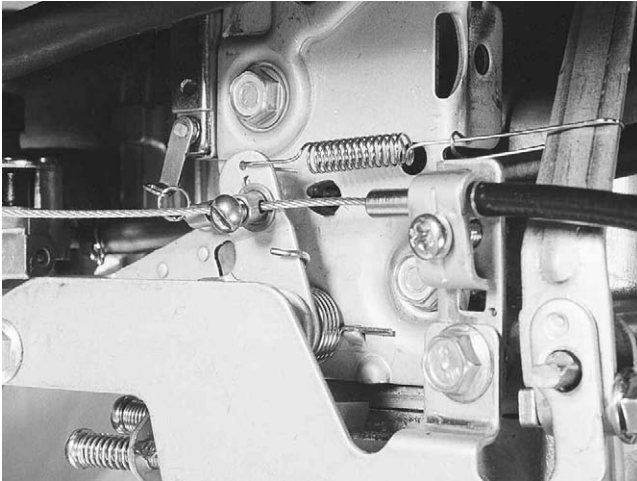

FIGURE 26



DANGER

BEFORE OPERATING THE HOLE DIGGER, DETERMINE THAT THE FORCED IDLE GOVERNOR SPRING (IF REQUIRED) IS IN PROPER MECHANICAL CONDITION AND IS PROPERLY ATTACHED TO THE ENGINE. DO NOT OPERATE THE HOLE DIGGER IF THE FORCED IDLE GOVERNOR SPRING IS

MISSING AND/OR IMPROPERLY ATTACHED TO THE ENGINE. SUCH AN OPERATING CONFIGURATION MAY NOT ALLOW THE ENGINE TO OBTAIN THE SPECIFIED IDLE SPEED, RESULTING IN PROPERTY DAMAGE AND/OR PERSONAL INJURY.

To determine if the engine requires the use of a forced idle governor spring system, contact your local Honda engine dealer or our Customer Service Department BEFORE utilization. There is no charge for this service.

INSTALLING THE COMPOSITE MATERIAL OPERATOR HANDLES.

APPLICATIONS: MODELS 330T, 343T AND 357T POWERED BY THE TECUMSEH VLV60 4 CYCLE GASOLINE ENGINE ONLY.

Tools Required:

- 2 each, 1/2 inch wrenches
- 1 each, 5/16 inch wrench
- 1 each, torque wrench, 240 inch pound capacity with 1/2 inch socket
- 1 each, small flat bladed screwdriver
- 1 each, phillips head screwdriver
- 1 each, small vice grip pliers
- 1 each, cut off pliers

The assembly of the operator handles to the transmission will require a level working platform of sufficient size and approximate height. As an alternative, the transmission shaft assembly can be securely mounted in a suitable bench vice.

1) Open the bag of assorted hardware into a suitable container in order to minimize the possibility of losing any part.

2) Assemble the steel handle reinforcements over the handles and align the holes so that the retaining cap screws can be readily inserted. The reinforcement with the welded throttle cable guide is assembled to the throttle control handle. FIGURE 27.

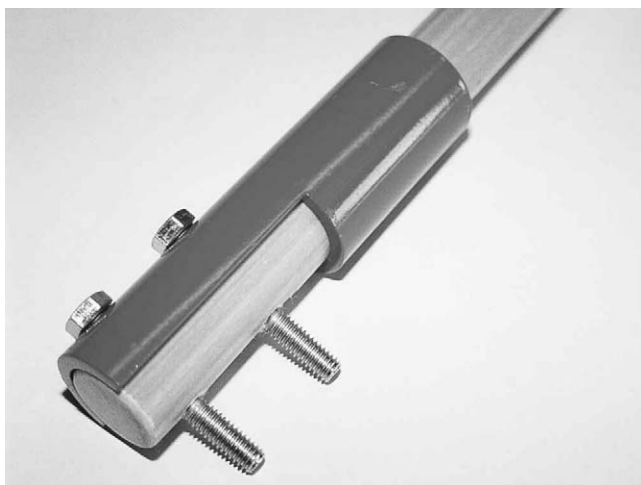

FIGURE 27

3) Facing the spark plug side of the engine, install the plain operator handles into the transmission case sockets with the supplied cap screws facing upwards. FINGER TIGHTEN ONLY. DO NOT FINAL TORQUE THE FASTENERS AT THIS TIME. FIGURE 28.

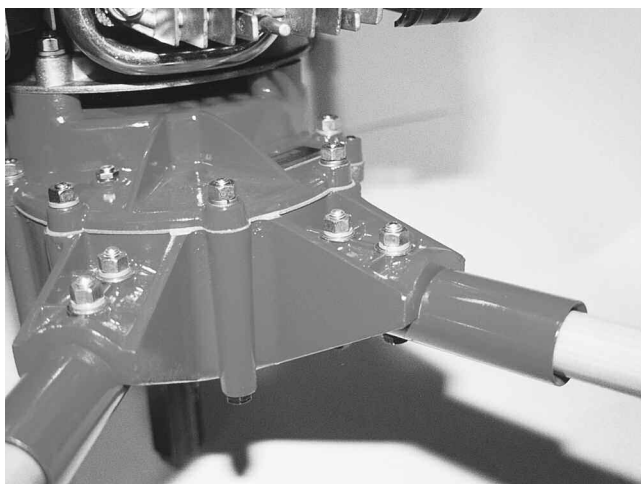

FIGURE 28

4) Facing the fuel tank side of the engine, install the operator handle with the throttle control/throttle cable into the transmission socket on the right side with the aluminum nameplate facing upwards. Secure with hardware as above. On the left side, install the remaining plain operator handle and secure with hardware as above. The Hole Digger is designed for the Magura® twist grip throttle control to be operated by the right hand. All operating instructions in this Operator's Manual are directed with the Magura® throttle control to be assembled and operated in the configuration as outlined in the **Assembly** section. Do not deviate the assembly and operation of the Magura® throttle control from that outlined in the Operator's Manual. FIGURE 29.

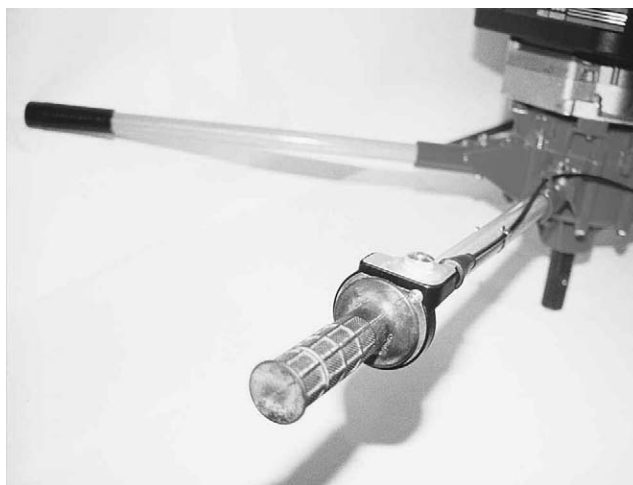

FIGURE 29



DANGER

IMPROPER ASSEMBLY AND OPERATION OF THE MAGURA® THROTTLE CONTROL WILL REDUCE THE CONTROLLABILITY OF THE HOLE DIGGER, RESULTING IN PROPERTY DAMAGE AND/OR PERSONAL INJURY.

5) Using the torque wrench, torque all handle cap screws evenly to 240 inch pounds (27 N.m).



CAUTION

Excessive fastener torque values can lead to subsurface fractures in the material resulting in premature failure of the handle. Frequently check the handle attach areas for signs of cracking and fatigue. Replace any operator handle of questionable structural qualities with a factory replacement part only.

6) Route the throttle cable assembly into the guide located on the handle reinforcement and into the throttle cable attach bracket located on the engine near the fuel tank ON/OFF valve. The attach bracket should be in full contact with the aluminum end of the throttle cable. Use the Phillips screw driver to temporary secure. FIGURE 30.



FIGURE 30

7) Using the flat blade screwdriver, remove the short length of wire from the swivel assembly located in the carburetor throttle arm. Route the inner wire into the hole of the swivel assembly. The small flat washer must be located between the inner wire and the throttle arm to minimize friction and extend the service life of all components. FIGURE 31.



FIGURE 31

8) Determine the carburetor throttle arm is in the ignition cut-off position toward the engine spark plug. This is the normal position for the throttle arm.

9) Using the vice grip pliers, remove any excess inner wire slack and tighten the swivel assembly screw using the flat bladed screwdriver and 5/16 inch wrench. The pulling movement with the vice grip pliers must not rotate the Magura® throttle control. Release the inner wire and allow the carburetor throttle arm to move back to its original position. The throttle arm return spring is designed to rapidly return the engine to idle speed/ignition cut-off when the throttle control is

released. If this is not occurring, check the throttle control assembly for possible causes of binding and movement restrictions. Adjust the swivel assembly as necessary to allow for complete freedom of movement. FIGURE 32.

DANGER

FOR OPERATIONAL SAFETY AND PRODUCTIVITY CONSIDERATIONS, IT IS EXTREMELY IMPORTANT THAT INNER WIRE SLACK BE COMPLETELY REMOVED FROM THE THROTTLE CONTROL SYSTEM. INNER WIRE SLACK CAN REDUCE OVERALL OPERATOR CONTROL, RESULTING IN PROPERTY DAMAGE AND/OR PERSONAL INJURY.



FIGURE 32

10) Rotate the throttle control counterclockwise (the maximum speed position) to determine that the inner wire pulls the throttle lever of the carburetor forward to its maximum speed position. Improper adjustment will not allow the engine to operate at its maximum, no load, governed speed and affect the overall digging performance of the Hole Digger. Adjust the swivel assembly and throttle cable attach bracket as necessary to allow for complete freedom of movement. Check for possible throttle cable inner wire binding and movement restrictions caused by the handle reinforcement and clamp. Rework and adjust as necessary to allow for complete freedom of movement. FIGURE 33.



FIGURE 33



DANGER

DO NOT OPERATE THE HOLE DIGGER WITH THE IGNITION CUT-OFF SYSTEM IN AN IMPROPER WORKING CONDITION. AN IGNITION CUT-OFF SYSTEM IN AN IMPROPER WORKING CONDITION CAN CONTRIBUTE/CAUSE LOSS OF MACHINE CONTROL. THIS OCCURRENCE CAN RESULT IN PROPERTY DAMAGE AND/OR PROPERTY DAMAGE.

11) Using the cut off pliers, cut off the remaining inner wire behind the swivel assembly, leaving approximately one inch (25.4 mm) of excess wire.

12) Check all fasteners for security. Consult a fastener torque chart for the proper torque value if any fastener is found to require retorquing.

Before Starting the Engine

FILLING THE ENGINE CRANKCASE WITH OIL.

APPLICATION: ALL 4 CYCLE ENGINE POWERED MODELS.

Tools Required:

- 1 each, small, adjustable wrench (if needed)
- 1 each, small, clean funnel with a flexible extension spout

Filling the engine crankcase with oil will require a level working platform of sufficient size and appropriate height. As an alternative, the transmission driveshaft can be securely in a suitable bench vise.

1) Wipe any dust or dirt from the crankcase

dipstick/filler plug area. Remove the dipstick/filler plug.

2) Using the funnel, add oil to the engine crankcase. For proper classifications and/or amount, consult the material supplied by the engine manufacturer for specific information.

3) Relace the dipstick/filler plug and tighten. Wipe off any excess spilled oil. Properly dispose of the spilled oil.

4) Consult the material supplied by the engine manufacturer for other service related information including oil change interval.



CAUTION

DO NOT OPERATE THE HOLE DIGGER UNLESS PROPER OIL LEVEL IS MAINTAINED. IMPROPER OIL LEVEL CAN RESULT IN PROPERTY DAMAGE AND/OR PERSONAL INJURY. CONSULT THE MATERIAL SUPPLIED BY THE SPECIFIC ENGINE MANUFACTURER FOR INFORMATION RELATIVE TO PROPER MAINTENANCE PROCEDURES.

FILLING THE HOLE DIGGER TRANSMISSION WITH OIL.

APPLICATION: ALL MODELS.

Tools Required:

- 1 each, small adjustable wrench.
- 1 each, small, clean funnel with a flexible extension spout.

Filling the transmission with oil will require a level working platform of sufficient size and appropriate height. An alternative, the transmission driveshaft can be securely mounted in a suitable bench vise.

1) Wipe any dust or dirt from the transmission oil filler/level plug area. The oil filler/level plug is located on the side of the transmission. Remove the plug with the adjustable wrench.

2) Using the funnel, pour 1 US quart (0.94 liter) of General Equipment Company transmission and Engine Oil, PN 999-11, **or** a high grade, SAE 30 Detergent or 10W30 motor oil into th transmission though the oil filler/level plug opening. Use only an oil marked with an engine service classification SF, SG, or SH/CD. As a general rule, the transmission is usually filled with the same oil type and weight that is utilized in the applicable 4-Cycle engine crankcase. FIGURE 34.

3) The transmission oil level is to be maintained at the bottom of the oil filler/level plug hole. Allow any excess

oil to drain out of the transmission. This procedure determines the correct oil level for the transmission. Correct oil level is important to insure proper centrifugal clutch operation. Maintaining the oil level too high will cause excessive centrifugal clutch slippage and result in high oil temperature. Excessive slippage and high oil temperature will significantly reduce the service life of the clutch assembly and affect the overall performance of the Hole Digger.

4) Inspect the oil filler/level plug gasket for proper security. If necessary, replace the gasket with a factory approved replacement part only. Reinstall the oil filler/level plug. Tighten securely with the adjustable wrench. Wipe off any excess oil spilled on the transmission. Properly dispose of the spilled oil.



FIGURE 34

TRANSMISSION OIL RECOMMENDATIONS.

APPLICATION: ALL MODELS.

Operating Temperature	Oil Type & Weight
Above 32°F	SAE 30, 10W30, 10W40, 15W40
Below 32°F	SAE, 5W30

FILLING THE ENGINE FUEL TANK.

APPLICATION: MODELS 310F, 342F AND 356F HOLE DIGGERS POWERED BY THE SUBARU EC10 SERIES 2 CYCLE ENGINE ONLY.

Tools Required:

1 each, small, clean funnel

 **DANGER**

FUEL/OIL MIXTURE RATIO: VARIABLE FROM 25:1 to 50:1 FUEL TO OIL MIXTURE RATIO.

 **DANGER**

THE 310F, 342F AND 356F HOLE DIGGERS UTILIZE A 2 CYCLE GASOLINE ENGINE WHICH REQUIRES A MIXTURE OF GASOLINE AND OIL IN THE FUEL TANK FOR OPERATION. THIS ENGINE DOES NOT UTILIZE A SEPARATE OIL INJECTION SYSTEM IN THE ENGINE CRANKCASE FOR LUBRICATION. THE OIL IN THE ENGINE CRANKCASE IS UTILIZED AS A DAMPENING MEDIUM FOR THE ENGINE GOVERNOR. IT DOES NOT FUNCTION AS A LUBRICATION SOURCE FOR THE ENGINE. FAILURE TO OPERATE THE ENGINE WITHOUT THE CORRECT FUEL/OIL MIXTURE RATIO WILL RESULT IN ENGINE DAMAGE AND/OR PERSONAL INJURY.

1) Carefully clean the filler cap and surrounding area to insure that no dirt or debris falls into the gasoline tank.

2) Use a high quality two cycle engine oil as specified in the material provided by the engine manufacturer. Disregard the mixing instructions on oil containers. **DO NOT MIX OIL DIRECTLY IN THE FUEL TANK.**

3) Mix oil with fresh, clean, gasoline as outlined in the information supplied by the engine manufacturer. To insure thorough mixing of the oil and gasoline, fill a clean, UL® approved, gasoline container to one quarter full. Add the appropriate amount of oil for mixture with one gallon of gasoline. Shake the container vigorously and then fill the remainder of the container with gasoline. Once mixed, the oil and gasoline will not separate.

4) Use of a properly blended gasoline for operation during the intended season will result in easier engine starting. Do not use gasoline left over from the previous season of operation.

5) The engine comes equipped with a fine screen fuel strainer in the fuel tank. This strainer will reduce the volume flow rate when gasoline is poured through it. Allowance for possible fuel spills by exceeding its volume flow capacity should be made whenever filling the fuel tank. Fuel spills can lead to the possibility of property damage and/or personal injury. Do not remove

the fuel strainer from the fuel tank. The carburetor utilized on the Subaru EC10 Series engine requires the fine screen to filter out contamination in the fuel mixture. FIGURE 35 .

DANGER

DO NOT SMOKE NEAR THE FUEL TANK. DO NOT FILL THE FUEL TANK WITH THE ENGINE RUNNING OR IF IT IS HOT. ALLOW AMPLE TIME BETWEEN EACH REFUELING FOR THE ENGINE TO COOL. AN IGNITION SOURCE IN CLOSE PROXIMITY TO THE FUEL TANK CAN BE THE SOURCE OF AN EXPLOSION, RESULTING IN PROPERTY DAMAGE AND/OR PERSONAL INJURY. CONSULT THE MATERIAL SUPPLIED BY THE SPECIFIC ENGINE MANUFACTURER FOR INFORMATION RELATIVE TO PROPER FUELING PROCEDURES.



FIGURE 35

DANGER

DO NOT OPERATE THE ENGINE WITHOUT THE PROPER FUEL/OIL MIXTURE RATIO. AN IMPROPER FUEL/OIL MIXTURE RATIO CAN RESULT IN ENGINE DAMAGE AND/OR PERSONAL INJURY.

FILLING THE ENGINE FUEL TANK.

APPLICATION: ALL MODELS POWERED BY 4 CYCLE ENGINES.

Tools Required:

1 each, small, clean funnel.

CAUTION

Never mix oil with gasoline for use in a 4 cycle engine. Damage to the engine can result. Four cycle engines do not utilize oil mixed with gasoline for lubrication purposes.

- 1) Carefully clean the filler cap and the surrounding area to insure that no dirt or debris falls into the fuel tank.
- 2) Fill the fuel tank with gasoline as per the material supplied by the specific engine manufacturer.
- 3) Fill the tank completely. Do not overfill the tank or spill any gasoline. Replace the filler cap. Wipe any excess spilled gasoline from the fuel tank area. Properly dispose of any gasoline wiped from the fuel tank area.

DANGER

DO NOT SMOKE NEAR THE FUEL TANK. DO NOT FILL THE FUEL TANK WITH THE ENGINE RUNNING OR IF IT IS HOT. ALLOW AMPLE TIME BETWEEN EACH REFUELING FOR THE ENGINE TO COOL. AN IGNITION SOURCE IN CLOSE PROXIMITY TO THE FUEL TANK CAN BE THE SOURCE OF AN EXPLOSION, RESULTING IN PROPERTY DAMAGE AND/OR PERSONAL INJURY. CONSULT THE MATERIAL SUPPLIED BY THE SPECIFIC ENGINE MANUFACTURER FOR INFORMATION RELATIVE TO PROPER FUELING PROCEDURES.

Digging Operation

OPERATIONAL DISCLAIMER.

APPLICATION: ALL MODELS.

THE MANUFACTURER OF THIS HOLE DIGGER MAKES NO WARRANTY OR GUARANTEE THAT IT IS MERCHANTABLE AND/OR SUITABLE FOR SPECIFIC JOB APPLICATION AND THAT IT WILL HAVE THE POWER REQUIRED TO DIG A SPECIFIC DIAMETER HOLE DOWN TO A SPECIFIC DEPTH IN A SPECIFIC SOIL CLASSIFICATION.

CALIFORNIA PROPOSITION 65 DISCLAIMER.

APPLICATION: ALL MODELS.



THE ENGINE EXHAUST FROM THIS PRODUCT CONTAINS CHEMICALS KNOWN TO THE STATE OF CALIFORNIA TO CAUSE CANCER, BIRTH DEFECTS, OR OTHER REPRODUCTIVE HARM.

SPARK ARRESTER DISCLAIMER.

APPLICATION: ALL MODELS.



DO NOT OPERATE THE HOLE DIGGER ON ANY FOREST COVERED, BRUSH COVERED OR GRASS COVERED, UNIMPROVED LAND UNLESS AN APPROVED SPARK ARRESTER IS INSTALLED ON THE MUFFLER. THE SPARK ARRESTER MUST BE MAINTAINED IN PROPER WORKING ORDER BY THE OWNER AND/OR OPERATOR. IN THE STATE OF CALIFORNIA, THE ABOVE IS REQUIRED BY LAW. OTHER STATES MAY HAVE SIMILAR LAWS. FEDERAL LAWS WILL APPLY ON FEDERAL LANDS.

INFORMATION RELATIVE TO MINIMUM COMPONENT STANDARDS FOR THE OPERATION OF THE HOLE DIGGER.

APPLICATION: ALL MODELS

For operational safety and overall productivity

considerations, it is required that specific Hole Digger components meet minimum acceptable operational standards as follows:

1) Operator handles be properly mounted to the transmission case sockets, per the requirements of the specific model and be of proper structural integrity with no cuts or abrasions greater than 0.125 inch (3.2 mm) deep.

2) Operator handles are each equipped with a properly fitting handle grip of sufficient integrity to allow for proper job function as outlined within this manual. Loose fitting handle grips or grips without full end caps are not permitted.

3) Throttle cable is in a proper mechanical condition that allows it to perform its intended job function as outlined within this manual. Cables with bends, abrasions or other damage that restrict or limit inner wire movement must be replaced with a factory approved replacement only.

4) Throttle control is installed in the correct operating position and be in a mechanical condition that allows it to perform its intended job function as outlined within this manual. Worn or damaged throttle control hand grip or other, internal parts must be replaced with a factory approved replacement parts only. Do not operate the Hole Digger with the aluminum protective cover missing. Do not allow foreign material to accumulate within the throttle control assembly. Clean all throttle control components and repair as necessary on a regular maintenance schedule.

5) An ON/OFF engine ignition switch (if so equipped) or an ignition cut off switch (if so equipped) that allows it to perform its intended job function as outlined within this manual. Replace any damaged ON/OFF ignition switch or ignition cut off switch with a factory approved replacement part only.

6) Centrifugal clutch assembly in proper mechanical condition that allows it to perform its intended job function as outlined within this manual. Replace any centrifugal clutch assembly with operational characteristics that do not allow it to properly disengage at the specified engine idle speed or properly slip during overload conditions.

7) Each auger is in a structural condition that allows it to perform its intended job function as outlined within this manual. Auger axles shall not be bent at any portion of its length. Augers with bent axles are to be discarded and not utilized under any circumstances.

8) Earth auger(s) has/have replaceable wear parts (screw bit and teeth) that allow(s) it/them to perform its/their intended job function as outlined within this manual. An auger with a screw bit and/or tooth/teeth worn past usual service life limits are not to be utilized under any circumstances.



DANGER

OPERATION OF A HOLE DIGGER UTILIZING COMPONENTS NOT MEETING MINIMUM ACCEPTABLE OPERATIONAL STANDARDS CAN RESULT IN PROPERTY DAMAGE AND/OR PERSONAL INJURY.

INFORMATION RELATIVE TO COMPOSITE MATERIAL OPERATOR HANDLES.

APPLICATION: ALL MODELS.



CAUTION

The Hole Digger may utilize operator handles constructed of a specially designed, composite material intended to reduce machine weight and help absorb the shock loads transmitted to the operators during the digging process. This material has shown to be very durable and will offer a very acceptable service life. However, it will not tolerate the same amount of external damage as steel tubing without some sacrifice of its appearance and/or physical strength properties. Protect the handles from external sources of damage. Do not allow the handles to come in contact with augers, shovels, or other sharp and abrasive objects during transit. Do not stack or throw similar objects on the handles during storage. Keep the handles clean and free of dirt, moisture, grease, oil and other, foreign material accumulations. Exercising proper preventative maintenance for the handles will result in an extended service life.



DANGER

USE OF THE COMPOSITE MATERIAL OPERATOR HANDLES DOES NOT ELIMINATE THE POTENTIAL FOR PROPERTY DAMAGE AND/OR PERSONAL INJURY IF CONTACT WITH A BURIED ELECTRICAL CABLE IS MADE. SEE: "DETERMINATION OF POTENTIAL SUBSURFACE HAZARDS IN THE PROPOSED DIGGING CONDITION(S)" ELSEWHERE IN THIS OPERATOR MANUAL.

1) Operator handles are constructed from a composite material with a demonstrated high dielectric constant. This insulating characteristic alone does not guarantee that contact with a buried electrical cable will not allow energy to be transmitted directly to the operators. Other factors reducing the insulating characteristics of the operator handle configuration include, but are not limited to:

a) Throttle cable. The throttle cable connects directly to the engine according to the design offered by the specific engine manufacture. The throttle cable is manufactured from conductive type materials for strength and durability purposes. This allows energy to flow from the auger through the engine and directly to the Magura throttle control.

b) Throttle control. The Magura throttle control is fabricated from aluminum and plastic. There is no guarantee the design configuration will eliminate energy being transmitted from the throttle cable, through the throttle control and directly to the operator.

c) External condition of the operator handles. Accumulation of moisture, dirt, pitch and other foreign substance can provide a conductive pathway for energy to be transmitted from the exterior of the operator handle and directly to the operator. It is recommended that operator handles be maintained in a clean, dry condition and free of all foreign materials.

2) The composite material is formulated by its manufacturer with an inhibitor to reduce (but not eliminate) the long term effects of ultra violet radiation from the sun. However, it is still recommended the composite material operator handles be protected from ultra violet radiation whenever possible to extend their service life.

3) Composite material operator handles are coated with a clear, polyurethane finish to help protect from external damage and abuse. When performing preventative maintenance on the Hole Digger, the protective covering can be restored by lightly sanding the handle surface with 240 grit sandpaper and then applying two thin coats of clear polyurethane.



CAUTION

Wear all appropriate safety apparel and equipment when utilizing the sandpaper and clear polyurethane spray. Follow all appropriate safety precautions for the use of these materials.

4) A composite material operator handle with a cut or abrasion greater than 0.125 inch (3.2 mm) deep must be removed from service and replaced with a factory approved replacement part only.

5) Do not operate the Hole Digger without the proper handle reinforcement properly attached to the transmission case sockets.



CAUTION

Handle reinforcements provide proper structural integrity. Use of the Hole Digger without the proper operator handle reinforcement can result in property damage and/or personal injury.

6) Do not utilize chains or slings wrapped around the composite material operator handles to help remove a Hole Digger which has become stuck in the ground.



DANGER

USE OF CHAINS AND/OR SLINGS WRAPPED AROUND THE COMPOSITE MATERIAL OPERATOR HANDLES TO HELP REMOVE A HOLE DIGGER FROM THE GROUND CAN RESULT IN DAMAGE TO THE HANDLES AND TRANSMISSION. THIS OCCURRENCE CAN LEAD TO PROPERTY DAMAGE AND/OR PERSONAL INJURY.

7) Regardless of actual use, all composite material operator handles have a maximum service life of 6 years. Replace any handles subject to this time limit with a factory approved replacement part only.



DANGER

OPERATION OF A HOLE DIGGER WITH OPERATOR HANDLES NOT MEETING THE DESCRIBED REQUIREMENTS AND/OR OPERATING PARAMETERS CAN RESULT IN PROPERTY DAMAGE AND/OR PERSONAL INJURY.

GENERAL TRANSPORTATION INFORMATION.

Application: All models.

When transporting the Hole Digger in/on a motor vehicle, the gasoline tank breather vent (if so equipped) must be completely closed to eliminate the accidental seepage of fuel and resulting potential fire hazard. In order to minimize the possibility of damage to the Hole Digger, always transport it to the job site with the auger disconnected. Failure to properly transport the Hole Digger can cause transmission oil to become entrapped in the centrifugal clutch assembly. Such an occurrence can cause excessive clutch slippage until the oil properly drains. All equipment must be secured in/on vehicles with suitable strapping or tie downs. Personnel should not be transported in the same compartment as equipment and fuel supplies. Consult applicable OSHA regulations.

DETERMINATION OF POTENTIAL SUBSURFACE HAZARDS IN THE PROPOSED DIGGING LOCATION(S).

Applications: All models.



DANGER

BEFORE ATTEMPTING TO DIG WITH THE HOLE DIGGER, DETERMINE THE POTENTIAL SUBSURFACE HAZARDS WHICH MAY EXIST IN THE PROPOSED DIGGING LOCATION(S). POTENTIAL SUBSURFACE HAZARDS MAY INCLUDE, BUT NOT BE LIMITED TO THE FOLLOWING:

- 1) ROCKS OF ANY SIZE.
- 2) ROOTS OF ANY SIZE.
- 3) BURIED MATERIALS SUCH AS GARBAGE AND OTHER DEBRIS.
- 4) BURIED PRESSURIZED PIPELINES CONTAINING SUCH MATERIALS AS NATURAL GAS, PROPANE, ETC.
- 5) BURIED ELECTRICAL CABLES.



DANGER

BEFORE ATTEMPTING TO DIG WITH THE HOLE DIGGER IN THE PROPOSED LOCATION(S), CONTACT ALL APPROPRIATE AGENCIES TO DETERMINE THE EXACT LOCATION(S) OF ALL BURIED PIPELINES, POWER LINES AND MATERIAL DEBRIS. MANY UTILITIES AND OTHER AGENCIES WILL

PERFORM THESE TASK AT MINIMAL CHARGE OR NO COST. HAVE ALL SUBSURFACE HAZARDS MARKED FOR EASY RECOGNITION. MACHINE CONTACT WITH THESE AND OTHER SUBSURFACE HAZARDS CAN RESULT IN PROPERTY DAMAGE AND/OR PERSONAL INJURY.

SET UP FOR DIGGING.

Applications: All models.

1) The Hole Digger is designed for two operators to transport it by the operator handles to, while on, and from the job site. Connect the auger to the Hole Digger with the correct factory supplied auger pin. Depending upon the specific model, a variance in auger pin part number and design configuration exists. Models 310, 310F, 330, 330B, 330H, 356F, 357H, 330T and 357T utilize the 3/8 inch (9.5mm) diameter, PNG 2121 auger pin. Models 324F, 343B, 343H and 343T each utilize the 5/16 inch (7.9mm) diameter, PNG 2021 auger pin. FIGURE 36.

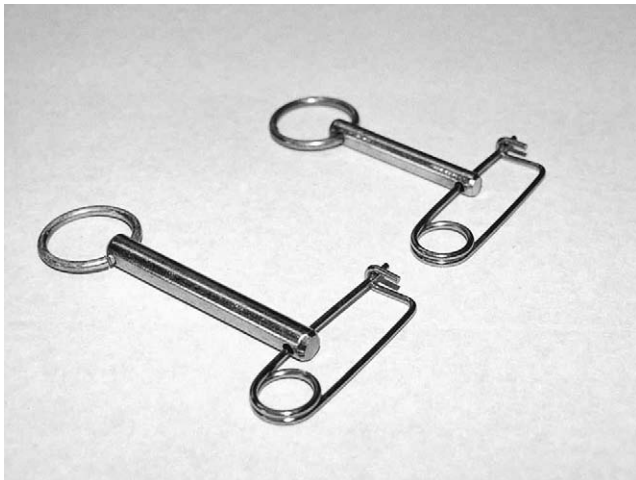

FIGURE 36

 **CAUTION**

When installing the auger and auger pin, always place the Hole Digger with the engine spark plug in the upward position to minimize the potential for gravity to allow oil and/or gasoline to enter into the combustion chamber and create a hydraulic lock up. Such an occurrence can result in property damage and/or personnel injury.

 **CAUTION**

The factory supplied auger pin is designed to withstand the high stresses encountered while digging. Use of any other connecting device, including cap screws, bolts, pins, etc., can result in damage to the Hole Digger driveshaft and/or auger drive hub. Improper connecting devices can cause property damage and/or personal injury.

 **DANGER**

DO NOT CONNECT THE AUGER TO THE HOLE DIGGER WITH THE ENGINE RUNNING. A SUDDEN AND/OR UNEXPECTED CHANGE IN THE ENGINE SPEED CAN RESULT IN HOLE DIGGER DAMAGE AND/OR PERSONAL INJURY.

 **DANGER**

THE HOLE DIGGER IS DESIGNED FOR TWO MAN OPERATION. USE BY ONLY ONE OPERATOR OR BY MORE THAN TWO OPERATORS WILL LEAD TO CONFUSION AND LOSS OF CONTROL, RESULTING IN PROPERTY DAMAGE AND/OR PERSONAL INJURY. THE CONTROLS ARE DESIGNED FOR ONE OPERATOR (CREW MEMBER) TO START THE ENGINE AND OPERATE THE ENGINE CHOKE CONTROL WHILE THE OTHER OPERATOR (CREW CHIEF) REGULATES ENGINE SPEED WITH THE TWIST GRIP THROTTLE CONTROL.

STARTING THE ENGINE WITH THE AUGER ATTACHED.

APPLICATION: 310F, 342F and 356F HOLE DIGGERS POWERED BY THE SUBARU EC10 SERIES 2 CYCLE ENGINE ONLY.

1) Grass and other overgrowth conditions will hamper the digging characteristics of any earth auger by becoming "clogged" around the auger teeth and screw bit. Removal of such obstructions from the hole location before attempting to dig will increase digging efficiency and overall productivity.

2) Place the Hole Digger in a vertical orientation on the desired hole location. The operators should position themselves on firm footing.

3) Open the gasoline tank breather vent (if so equipped) to its maximum set position. Failure to properly open the breather vent will prevent the engine from receiving a continuous supply of fuel.

4) The Crew Chief turns the fuel ON/OFF valve located under the fuel tank to the ON position. The Crew Member turns the ignition ON/OFF switch (if so equipped) to the ON position. FIGURE 37.



FIGURE 37

5) When attempting to start a cold engine, the Crew Member closes the engine choke by moving the choke lever upward against its stop. This procedure is to be followed regardless of the ambient temperature. An engine that has been operating may not require choking. FIGURE 38.

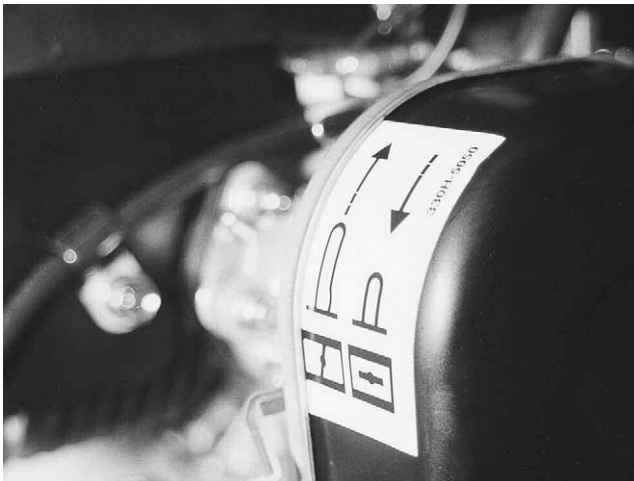

FIGURE 38

6) The Crew Chief operates the twist grip throttle control with his right hand and provides machine stability while holding the remaining handle with his left

hand. The Crew Chief rotates the twist grip throttle control counterclockwise (to open) half way against its stop. The Crew Member pulls the recoil starter handle until engine compression is felt. Then, he gives a fast, short, steady pull. Allow the starter rope to retract slowly. If the engine does not start after three pulls, stop and consult the information supplied by the engine manufacturer for specific information. As the engine warms up, the Crew Member moves the choke lever to the full open position.

7) Normally an engine that has not been run for some time requires three to five pulls before it will fire. On the other hand, a recently run engine will usually start on the first or second pull. In cold weather, initial starting will require additional pulls because an extremely rich fuel/air mixture is required.

8) Allow the engine to properly "warm up" and operate without the requirement for engine choke. Check for proper centrifugal clutch operation, excessive transmission noise and/or vibration.

9) Stopping the Hole Digger is accomplished by rotating the twist grip throttle control clockwise to its maximum, closed (engine idle speed) position. The Crew Member then turns the ignition ON/OFF switch to the OFF position. The Crew Chief turns the fuel value to the OFF position. FIGURE 39.

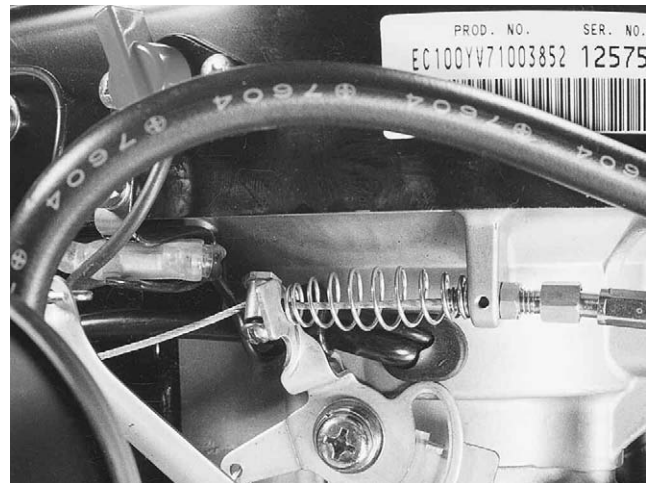

FIGURE 39

CAUTION

If the Hole Digger and/or an individual component/accessory does not appear to be functioning properly, STOP and do not further operate the Hole Digger until the necessary corrective action has been completed. If you have any questions regarding the proper operation of the

Hole Digger, contact the Customer Service Department BEFORE further utilization. There is no charge for this service.

STARTING THE ENGINE WITH THE AUGER ATTACHED.

APPLICATION: 330B, 343B and 357B HOLE DIGGERS POWERED BY THE BRIGGS & STRATTON 133702 SERIES 4 CYCLE GASOLINE ENGINE ONLY.

1) Grass and other overgrowth conditions will hamper the digging characteristics of any earth auger by becoming "clogged" around the auger teeth and screw bit. Removal of such obstructions from the hole location before attempting to dig will increase digging efficiency and overall productivity.

2) Place the Hole Digger in a vertical orientation on the desired hole location. The operators should position themselves on firm footing.

3) The Crew Chief opens the gasoline tank breather vent (if so equipped) to its maximum set position. Failure to properly open the breather vent will prevent the engine from receiving a continuous supply of fuel.

4) The Crew Chief opens the fuel ON/OFF valve located under the fuel tank to the ON position. FIGURE 40.

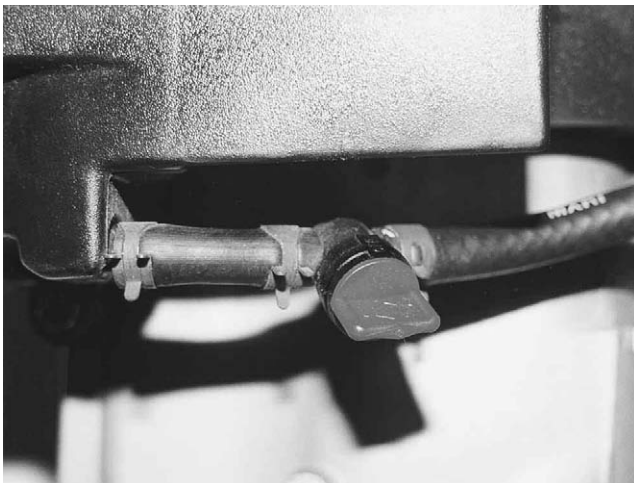

FIGURE 40

5) When starting a cold engine, the Crew Member depresses the engine primer bulb three times or as directed by the information supplied by the engine manufacturer. A warm engine may not require priming. FIGURE 41.

6) The Crew Chief operates the twist grip throttle control with his right hand and provides machine stability while holding the remaining handle with his left hand. The Crew Chief rotates the throttle control counterclockwise (to open) half way against its stop. The Crew Member then pulls the recoil starter handle until engine compression is felt. Then he gives a fast, short, steady pull. Allow the starter rope to retract slowly. If the engine does not start after three pulls, stop and consult the information supplied by the engine manufacturer for specific information.



FIGURE 41

7) Normally an engine that has not run for some time will require three to five pulls before it will fire. On the other hand, a recently run engine will usually start on the first or second pull. In cold weather, initial starting will require additional pulls because an extremely rich fuel/air mixture is required.

8) Allow the engine to properly "warm up" before operating at high speed. Check for proper centrifugal clutch operation, excessive transmission noise and/or vibration.

9) Stopping the Hole Digger is accomplished by rotating the twist grip throttle control clockwise to its maximum, closed position and allowing the throttle arm to engage the ignition cut-off switch. FIGURE 42

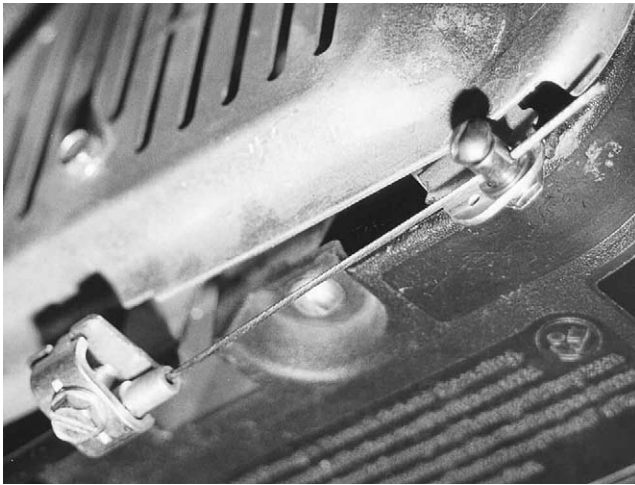

FIGURE 42



CAUTION

If the Hole Digger and/or an individual component/accessory does not appear to be functioning properly, STOP and do not further operate the Hole Digger until the necessary corrective action has been completed. If you have any questions regarding the proper operation of the Hole Digger, contact the Customer Service Department BEFORE further operation. There is no charge for this service.

STARTING THE ENGINE WITH THE AUGER ATTACHED.

APPLICATION: 330H, 343H and 357H HOLE DIGGERS POWERED BY THE HONDA GXV140 4 CYCLE GASOLINE ENGINE ONLY.

1) Grass and other overgrowth conditions will hamper the digging characteristics of any earth auger by becoming "clogged" around the auger teeth and screw bit. Removal of such obstructions from the hole location before attempting to dig will increase digging efficiency and overall productivity.

2) Place the Hole Digger in a vertical orientation on the desired hole location. The operators should position themselves on firm footing.

3) The Crew Chief opens the fuel tank breather vent (if so equipped) to its maximum set position. Failure to properly open the breather vent will prevent the engine from receiving a continuous supply of fuel.

4) The Crew Member opens the fuel tank ON/OFF valve located under the fuel tank to the ON position. FIGURE 43.

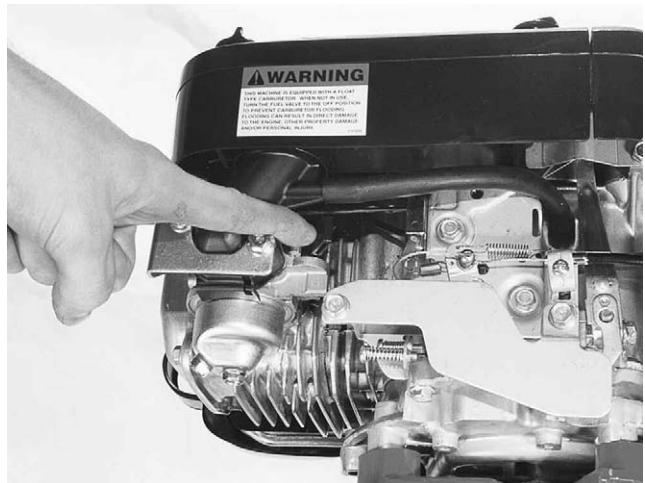

FIGURE 43

5) The Crew Chief operates the throttle control with his right hand and provides machine stability while holding the remaining handle with his left hand. The Crew Chief rotates the throttle control counterclockwise (to open) half way against its stop. The Crew Member closes the engine choke by pulling the control lever located above the carburetor out to its detent position. FIGURE 44.

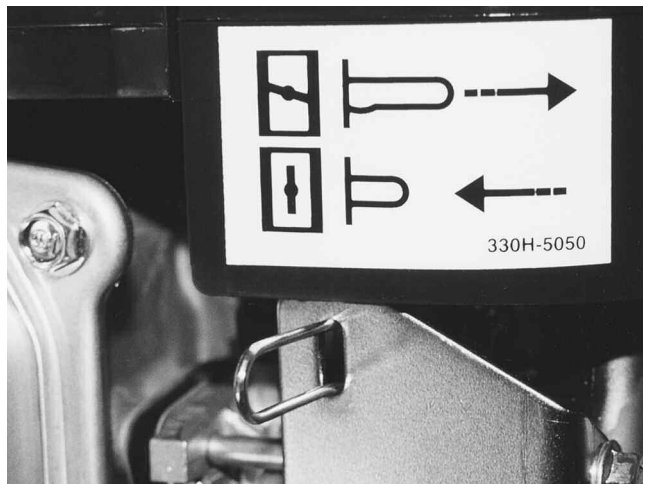

FIGURE 44

6) The Crew Member pulls the recoil starter handle until engine compression is felt. Then he gives a fast, short, steady pull. Allow the starter rope to retract slowly. If the engine does not start in three pulls, consult the material supplied by the engine manufacturer for specific information. As the engine warms up, the Crew Member pushes the choke lever in to its detent position.

7) Normally, an engine that has not been run for some time requires three to five pulls before it will fire. On the other hand, a recently run engine will usually start on the first or second pull. In cold weather, initial starting will require additional pulls because an extremely rich fuel/air mixture is required.

8) Allow the engine to properly "warm up" and operate without the requirement for engine choke. Check for proper centrifugal clutch operation, excessive transmission noise and/or vibration.

9) Stopping the Hole Digger is accomplished by rotating the twist grip throttle control clockwise to its maximum, closed position and allowing the throttle arm to engage the ignition cut-off switch. FIGURE 45.



FIGURE 45



CAUTION

If the Hole Digger and/or an individual component/accessory does not appear to be functioning properly, STOP and do not further operate the Hole Digger until the necessary corrective action has been completed. If you have any questions regarding the proper operation of the Hole Digger, contact the Customer Service Department BEFORE further utilization. There is no charge for this service.

STARTING THE ENGINE WITH THE AUGER ATTACHED.

APPLICATION: 330T, 343T and 357T HOLE DIGGERS POWERED BY THE TECUMSEH VLV60 SERIES 4 CYCLE GASOLINE ENGINE ONLY.

1) Grass and other overgrowth conditions will hamper the digging characteristics of any earth auger by becoming "clogged" around the auger teeth and screw bit. Removal of such obstructions from the hole location before attempting to dig will increase digging efficiency and overall productivity.

2) Place the Hole Digger in a vertical orientation on the desired hole location. The operators should position themselves on firm footing.

3) The Crew Chief opens the fuel tank breather vent (if so equipped) to its maximum set position. Failure to properly open the breather vent will prevent the engine from receiving a continuous supply of fuel.

4) The Crew Chief turns the fuel tank ON/OFF valve located under the fuel tank to the ON position. FIGURE 46.

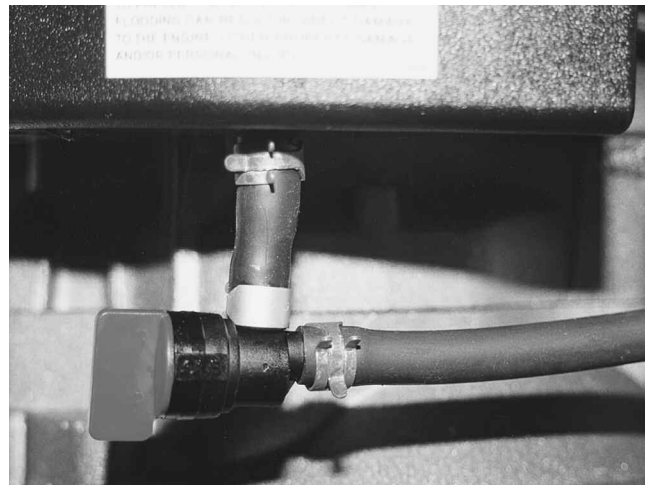

FIGURE 46

5) When starting a cold engine, depress the engine primer bulb three times or as directed by the information provided by the engine manufacturer. A warm engine may not require priming. FIGURE 47.



FIGURE 47

6) The Crew Chief operates the twist grip throttle control with his right hand and provides stability to the machine while holding the remaining handle with his left hand. The Crew Chief rotates the throttle control counterclockwise (to open) half way against its stop. The Crew Member pulls the recoil starter handle until engine compression is felt. Then he gives a fast, short, steady pull. Allow the starter rope to retract slowly. If the engine does not start after three pulls, stop and consult the information supplied by the engine manufacturer for specific information.

7) Normally an engine that has not run for some time will require three to five pulls before it will fire. On the other hand, a recently run engine will usually start on the first or second pull. In cold weather, initial starting will require additional pulls because an extremely rich fuel/air mixture is required.

8) Allow the engine to properly "warm up" before operating at high speed. Check for proper centrifugal clutch operation, excessive transmission noise and/or vibration.

9) Stopping the Hole Digger is accomplished by rotating the twist grip throttle control clockwise to its maximum, closed position and allowing the throttle arm to engage the ignition cut-off switch. FIGURE 48.

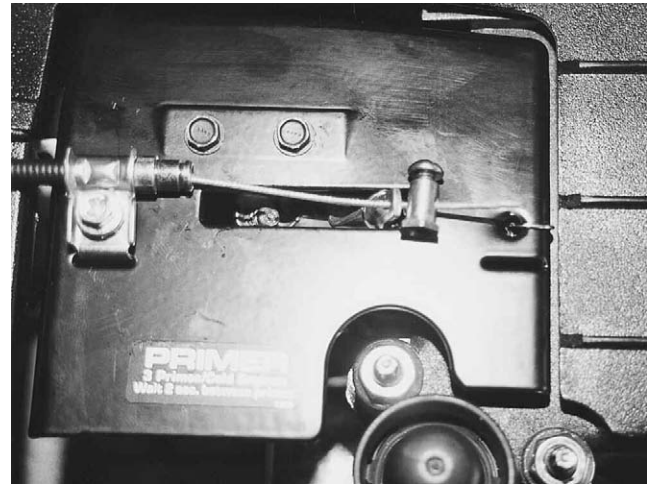

FIGURE 48

CAUTION

If the Hole Digger and/or an individual component/accessory does not appear to be functioning properly, STOP and do not further operate the Hole Digger until the necessary corrective action has been completed. If you have any questions regarding the proper operation of the Hole Digger, contact the Customer Service Department BEFORE further utilization. There is no charge for this service.

OPERATING THE HOLE DIGGER.

APPLICATION: ALL MODELS.

1) Do not attempt to begin digging with the Hole Digger until both the Crew Chief and Crew Member have acknowledged to each other that they are ready and are in full control of the machine.

2) The Crew Chief rotates the throttle control counterclockwise to increase the engine speed. The auger will begin to rotate when the engine speed reaches the centrifugal clutch initial engagement speed.

3) Normal operating procedure for the Hole Digger is to dig with the engine operating at full, governed speed to allow the centrifugal clutch to become more firmly engaged. This procedure will transmit more usable power to the auger, resulting in greater productivity and less component wear.



CAUTION

When digging in areas filled with known, buried obstructions such as tree roots, rocks and other debris, operate the Hole Digger at less than full, governed (an intermediate) speed to insure a more rapid release of the centrifugal clutch when an obstruction is encountered. This is an industry wide operating procedure.

4) The Hole Digger is equipped with a centrifugal clutch assembly within the transmission. Newton's Law of Physics allow the centrifugal clutch assembly to ALWAYS slip whenever overloaded or if the auger comes in contact with a buried obstruction. The response time for the centrifugal clutch assembly to react to an overload condition is directly proportional to its rotational speed. The higher the rotational speed (RPM) of the centrifugal clutch at the time of overload, the greater amount of time it requires to react and actually slip. This phenomenon is inherent with all centrifugal clutch assemblies. It is inherent with all powered equipment incorporating such a device.

UNDERSTANDING KICKBACK.

APPLICATIONS: ALL MODELS.

The operation of the Hole Digger involves engine torque being transmitted and multiplied by the transmission to the auger. The energy is then used to dig holes. But to every force (action), there is always a reaction force in the opposite direction. Thus, if the auger contacts a buried obstruction, the operators will feel the left side handles of the Hole Digger being "thrust" towards them. This "thrusting" force experienced by the operators is called kickback. The speed (and magnitude of the resulting impact force) at which the auger strikes the buried object is directly proportional to the amount/speed of the kickback force experienced by the operators. The torque and kickback generated by the digging process is inherent with a portable, two man Hole Digger and can not be eliminated by any operation and/or design characteristic. The operational effects are alike to that of utilizing a common, electric drill and other, rotation type, powered tools.

MINIMIZING KICKBACK FROM AN OPERATIONAL STANDPOINT.

APPLICATION: ALL MODELS.

Both operators should keep the left side handle as close to their body (left hip and leg areas) as possible to minimize machine "kickback" when a buried obstruction is encountered by the auger. Assume

operating positions that allow each to exercise reactive "body english" against the torque sensation created by the digging process. Keep upper arms as close to the upper body as possible to maximize mechanical leverage. Operators should position their backs as vertical as possible by bending the legs as required during the digging process. Positioning the left foot ahead of the right foot will enhance proper body position. Maintaining proper operating positions is one of the most IMPORTANT and EFFECTIVE procedures for controlling kickback. Improper operating positions only aggravate the effects of kickback upon the operators. FIGURE 49 depicts proper operator positions that enhance machine control. FIGURE 50, FIGURE 51 and FIGURE 52 depict improper operator positions that reduce machine control .



FIGURE 49



FIGURE 50



FIGURE 51



FIGURE 52

Keep a firm, but steady, grip on the operator handles. Wrap your fingers around the handle grips, keeping the grips cradled between the thumbs and forefingers. REMEMBER PROPER OPERATOR POSITIONS ENHANCE THE CONTROL OF THE HOLE DIGGER, REDUCE OPERATOR FATIGUE AND INCREASE OVERALL PRODUCTIVITY.



CAUTION

Maintain the operator handles and grips in good condition and free of moisture, pitch oil or grease. Wear gloves to improve your grip. Bent or damaged handles, or handles with damaged and worn and/or without grips aggravate the effects of kickback upon the operators by limiting control and comfort.

Handle grips should be repaired and/or replaced when they become worn and/or damaged from use. Do not operate the Hole Digger until such handles are repaired and/or replaced. Damage to property and/or personal injury can result.



CAUTION

Always assume that every digging site can include some form of buried obstruction. Always be prepared for unexpected auger contact with buried tree roots, rocks, etc. Under certain operating conditions, striking a buried obstruction can produce a severe and/or sudden kickback force to the hip and/or leg areas. Operators must maintain physical and mental alertness and be prepared to accommodate this phenomenon. Failure to properly accommodate this phenomenon can result in property damage and/or personal injury.

MINIMIZING KICKBACK FROM A DESIGN STANDPOINT.

APPLICATION: ALL MODELS.

1) The Hole Digger features the longest operator handles of any machine of its type and/or class. These handles are biomechanically positioned to enhance control by allowing the operators to exert "body english" against the torque and kickback forces generated by the digging process.

2) The Hole Digger utilizes antivibration handle grips on the operator handles to enhance control and help dampen the torque and kickback experienced by the operators during the digging process.



CAUTION

Do not operate the Hole Digger if the handle grips are worn and/or damaged from use. Replace the handle grips with factory approved replacement parts only.

3) The Hole Digger features operator handles constructed of a non metallic, composite material. The physical characteristics of this material allow it to help dampen the torque and kickback experienced by the operators during the digging process.

4) The Hole Digger utilizes a twist grip throttle control.

This type of throttle control device was selected over other configurations (for the operator handle configuration utilized and specific digging power) because it allows the operator to wrap his thumb around the forefinger and effectively maximize the strength in his right hand. This design feature affords the operator greater control of the machine when counteracting the effects of torque and kickback forces during the digging process.

5) The Hole Digger is designed to utilize the General Equipment Company part number 2121 pin to retain the earth auger to the transmission driveshaft. This pin is not intended to shear when the auger comes in sudden contact with a buried object.

The pins are utilized for the following reasons:

a) Such an occurrence (pin shear) would result in extensive physical damage to the driveshaft and auger drive hub.

b) Even if the physical damage to the Hole Digger could be eliminated and/or minimized from the actual processes, it could require an unknown (and potentially large) number of auger pins to complete the digging process for any specific hole.

c) Even if the cost of the replacement auger pins is not a factor, the resulting productivity produced by the actual process would not be deemed acceptable by industry and/or social standards for the Hole Digger.

d) Given the infinite number of soil conditions which could be encountered during the actual process, it is impossible to design and supply a specific auger pin to shear at a specific torque value which would produce acceptable operational results for the Hole Digger.

e) Given the infinite number of operators and their methods utilized during the actual process, it is impossible to design and supply a specific auger pin to shear at a specific torque value which would produce acceptable operational results for the Hole Digger.

f) Given the infinite number of combinations of soil conditions, auger diameter, auger boring head condition, digging depth, mechanical operating condition, operators and operator methods encountered during the actual process, it is impossible to design and supply a specific torque value which would produce acceptable operational results for the Hole Digger.

6) For comparison purposes, it is interesting to note that portable electric drills do not utilize any torque limiting or clutch device to allow the drill bit to slip at a specific torque value for drilling purposes. As with a Hole Digger, such a device would make the drill a useless tool because of the infinite number of potential

operating configurations and the inability to design specific components to meet the requirements of each operating configuration.

7) Many portable electric screwdrivers incorporate a torque limiting or clutch device which allows the operator to preset the torque output of the tool to a specific value. This is especially useful and desirable when hardware can be secured to specific torque values according to industry published standards.

8) Portable electric drill and screwdrivers are two separate tools designed for different and specific job applications. The drilling process has different requirements than the fastening process offered by screwdrivers. The operational characteristics of portable electric screwdrivers can not be confused and/or substituted for the operational characteristics of the Hole Digger.

OPERATING THE HOLE DIGGER CONTINUED.

APPLICATION: ALL MODELS.

5) Auger boring heads are designed for digging in a wide variety of soil types and/or conditions. Each boring head design represents a compromise in overall digging efficiency, productivity and service life for any given soil condition. As a general rule, pressing down on the operator handles is not required to initiate and/or sustain the digging process. In most soils of moderate Proctor Densities, augers will dig at rates that will not cause the centrifugal clutch to overload and slip. In most soft soils of low Proctor Densities (sandy, etc.), it may be necessary to hold up on the operator handles to reduce the digging rate of the auger. The natural tendency of any auger design, in low Proctor Density soil conditions, is to dig at a rate which causes the centrifugal clutch to overload and slip. In most hard soils of high Proctor Densities (hard clay, etc.), it may be necessary to press down on the operator handles to establish and maintain acceptable digging rates. Proper digging procedure for any given soil condition is the accumulation of actual experience, skill and common sense. For any given soil condition, allow the auger to dig at the rate most comfortable to the operators (exercising correct operating positions), yet not causing the centrifugal clutch to overload and slip.



CAUTION

An improper operating procedure can allow the auger to "bind" and/or "bury" itself in the hole. This is usually the result of allowing the auger to feed at an excessive rate. This phenomenon is also characteristic of digging with smaller diameter (2 to 4 inch) augers. In this condition, the Hole Digger is not capable of transmitting ample power to free

the auger. Do not continue to overload and slip the centrifugal clutch assembly. Excessive heat can be created by the slippage resulting in clutch component failure.



CAUTION

Damage to property and/or personal injury can result if one or more operators lose partial and/or full control of the Hole Digger while in this configuration. STOP the Hole Digger and remove it from the buried auger. The buried auger can then be retrieved by various, industry accepted methods. Contact the Customer Service Department for specific information. There is no charge for this service.

6) Some soil conditions may require more power to dig the hole than the Hole Digger is capable of delivering for a given auger diameter. This problem is more noticeable in areas of semiconsolidated soils or compacted soils having high Proctor Densities. Examples of such soil types include: soft shale, hard pan and caliche. The power required to dig a hole is directly proportional to the soil resistance encountered by the auger and the square of the auger diameter. For example: a 12 inch diameter auger requires 4 times the power than that of a 6 inch diameter, given identical soil conditions. This problem is best minimized (but not eliminated) by the addition of suitable down force by the operators and by utilizing augers equipped with new, replacement screw bits and teeth. Contact the Customer Service Department for information relative to your specific requirements. There is no charge for this service.



DANGER

IT IS A MISCONCEPTION THAT A LARGER DIAMETER HOLE CAN BE OBTAINED BY FIRST DIGGING AN INITIAL HOLE WITH A SMALLER, "PILOT" AUGER AND THEN UTILIZING A LARGER DIAMETER AUGER TO "REAM" THE HOLE TO THE DESIRED SIZE. THIS METHOD WILL NOT ALLOW THE AUGER SCREW BIT TO PRODUCE SUFFICIENT DIRECTIONAL STABILITY FOR THE LARGER DIAMETER AUGER DURING THE "REAMING" PROCESS. THIS METHOD WILL RESULT IN HOLE DIGGER DAMAGE, LOSS OF OPERATOR CONTROL AND/OR PERSONAL INJURY.

7) When digging in areas filled with small tree roots, small rocks or other buried obstructions, allow the auger teeth to "chip away" at the obstruction until the auger can pass by (by working the object loose) or go through it (as in the case of penetrating tree roots). This technique usually involves holding up on the operator handles and establishing a minimal feed rate for the auger. Proper operator position will minimize the effects of kickback being generated by the auger teeth contacting the object. As with any hole digging procedure, the mechanics of this technique require the accumulation of actual experience and common sense to maximize its effectiveness. Many times the size and nature of a buried object will simply prevent the auger from passing by or going through it. Continued digging with the Hole Digger will only contribute to equipment damage operator fatigue and/or injury. Instead, remove the buried object with a shovel or other suitable tool and proceed to dig the hole with the Hole Digger to the desired depth.



CAUTION

Some job applications may encounter buried obstructions that are too massive in size to allow the usage of a machine the size and/or with the operating limitations of the Hole Digger. Utilization of the Hole Digger on these work sites can cause property damage and/or personal injury. Exercise proper common sense by selecting the proper size and/or type of equipment for the job application.



CAUTION

Some job applications may encounter soil classifications that are too compacted to allow the usage of a machine the size and/or with the operating limitations of the Hole Digger. Utilization of the Hole Digger on these work sites can cause property damage and/or personal injury. Exercise proper common sense by selecting the proper size and/or type of equipment for the job application.

8) In most soil conditions, the auger will retract with less effort if allowed to rotate at a slow speed. This procedure, however, will leave more loose soil at the bottom of the hole. To minimize the amount of loose soil that remains at the bottom of the hole, stop the

rotation before retracting the auger. Proper procedure for obtaining the cleanest, most usable hole for any given soil condition requires the accumulation of actual skill, experience and common sense.

9) The twist grip throttle controls the digging process by regulating the engine speed. Keep a firm grip on it at all times. As with any safety device, it requires constant and proper maintenance to function as intended.

10) Attempting to restart the engine with the auger in a partially or completely dug hole requires extra caution. In this configuration, the throttle control can be advanced beyond the idle speed position before the two operators can exercise proper control of the Hole Digger. The more accepted procedure (when not utilizing both nonflighted and/or full flighted auger extensions) is to first remove the unit from the hole and restart the engine according to the described method. Return the unit to the hole with the engine running at idle speed and proceed to complete the hole to the desired depth.



CAUTION

To restart the engine with the auger in a partially or completely dug hole requires a higher degree of operator experience, skill and common sense over that of an introductory or novice level of expertise. The manufacturer is aware that many operators restart the Hole Digger's engine with the auger in a partially or completely dug hole on a regular basis while in the field. The manufacturer also realizes that this procedure must be utilized when auger extensions are utilized to extend the digging depth. The manufacturer has no control over the experience, skill and common sense levels of each operator of the Hole Digger. The manufacturer has no control over each job site or specific job application for the Hole Digger.

Individual operator experience, skill, common sense, job site location and specific job application must affect the final decision on specific operating procedures for the Hole Digger. Each operator must decide if he possesses adequate/proper experience, skill and common sense for operating the Hole Digger in any given and/or specific job application.

11) Both the auger teeth and screw bit must be replaced when signs of excessive wear are visible. A regularly scheduled maintenance program will increase

the service life of the auger and increase productivity by substantially reducing operator fatigue. An auger requiring replacement of the auger teeth and screw bit is depicted in FIGURE 53.



FIGURE 53



CAUTION

Do not utilize an auger with the auger teeth and screw bit worn past their specific service limits. Excessive wear to the auger teeth and screw bit will allow the auger flighting to wear in a tapered or inverted cone configuration. The worn boring head may actually be only capable of digging a hole 60 to 75 percent the nominal diameter of the auger. This configuration will allow the auger to "bind" within the hole and substantially reduce operator control and productivity.

12) Avoid placing serious stress to the back and other lower body members. Always lift in a straight line with your legs. Maintain the back in a vertical position as allowed by the digging process. Proper wrist position during the digging process can minimize and/or reduce stress and strain related damage potential to this body area. Operator control can be enhanced and fatigue reduced by attempting to keep wrists as perpendicular to the operator handles as feasible during the digging process. FIGURE 54



FIGURE 54

13) Stop the engine between each hole to minimize the possibility of personal injury. Special care must be exercised in slippery conditions and in difficult, overgrown terrain to minimize any trip and fall potential. This can be accomplished with good communication between the Crew Chief and Crew Operator, proper attire, including shoes and the removal of any trip and fall hazard BEFORE attempting to utilize the Hole Digger on the job site.



DANGER

TO REDUCE THE POTENTIAL FOR PERSONAL INJURY, STOP THE HOLE DIGGER BETWEEN EACH HOLE. DO NOT CHOOSE TO SAVE TIME (THE TIME REQUIRED TO RESTART THE ENGINE) AND MONEY (IN THE EVENT THE HOLE DIGGER IS BEING RENTED) BY ELECTING TO KEEP THE ENGINE RUNNING BETWEEN EACH HOLE. SUCH OCCURRENCE CAN LEAD TO LOSS OF CONTROL, RESULTING IN PROPERTY DAMAGE AND/OR PERSONAL INJURY.

STOPPING THE HOLE DIGGER.

Applications: 310F, 342F and 356F Hole Diggers powered by the Subaru EC10 Series 2-Cycle gasoline engine only.

1) Stopping the Hole Digger is accomplished by first rotating the twist grip throttle control clockwise to its maximum, closed position and allowing the engine to return to its idle speed. With the twist grip throttle control functioning properly, the engine can be brought to its idle speed and the auger rotation stopped when the throttle control is fully closed or suddenly released. If this is not

occurring, check the throttle control, throttle cable and engine idle speed for binding and/or improper adjustment. (Note: with the engine running at idle speed, there may be some slight auger rotation due to viscous drag within the centrifugal clutch assembly. The clutch is NOT engaged.) The Crew Member then turns the ignition ON/OFF switch to the OFF position or depressed the ignition switch to stop the engine (depending upon design variances between engines.)

2) When the engine is not in operation, turn the fuel tank ON/OFF valve to the OFF position to minimize the potential for fuel flooding the carburetor and/or entering the engine crankcase and/or impacting upon the environment.

STOPPING THE HOLE DIGGER.

Application: 330B, 343B and 357B Hole Diggers powered by the Briggs & Stratton 4-Cycle gasoline engine only.

Applications 330H, 343H, and 357H Hole Diggers powered by the Honda GXV140 4-Cycle gasoline engine only.

Applications 330T, 343T, and 357T Hole Diggers powered by the Tecumseh VLV60 4-Cycle gasoline engine only.

1) Stopping the Hole Digger is accomplished by rotating the twist grip throttle control clockwise to its maximum, closed position and allowing the throttle arm to engage the ignition cut-off switch. With the throttle control functioning properly, the engine can be brought to the specific idle speed, the auger rotation stopped (there may be some slight rotation due to viscous drag within the centrifugal clutch assembly. The clutch is NOT engaged.) and the ignition cut off when the throttle control is released or fully closed. If this is not taking place, or the ignition cut-off switch can not be engaged with throttle control movement, check the throttle control and throttle cable for binding and/or improper adjustment.

2) When the engine is not in operation, turn the fuel tank ON/OFF valve to the OFF position to minimize the potential for fuel flooding the carburetor and/or entering the engine crankcase and/or impacting upon the environment.

TEMPORARY STORAGE FOR THE HOLE DIGGER WHILE ON THE JOB SITE.

Applications: All models

The Hole Digger can be temporarily stored on the job site by one of three acceptable methods as determined by the operators based upon personal preference and/or job site conditions:

a) Digging a shallow hole and leaving the Hole Digger connected to the auger. FIGURE 55.

b) Disconnecting the Hole Digger from the auger and/or auger extension(s) and storing it in a level configuration. FIGURE 56.

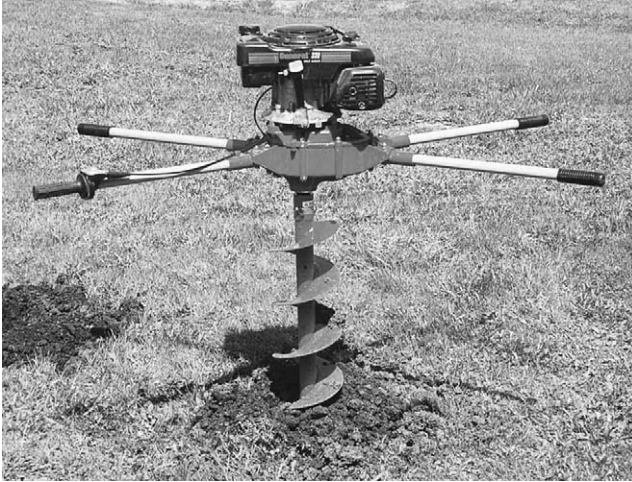

FIGURE 55



FIGURE 56

c) Storing the Hole Digger while connected only to a lead auger with the engine spark plug facing upward. If the Hole Digger is powered by a four cycle engine, this configuration will minimize the potential for crankcase oil entering the combustion chamber and causing a hydraulic lock up. FIGURE 57.

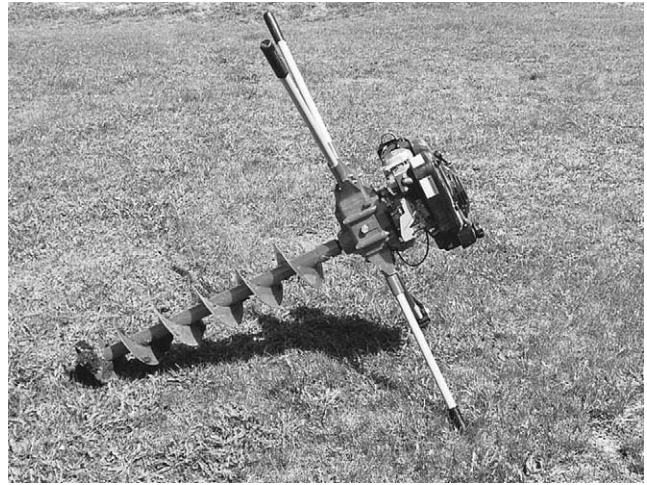

FIGURE 57



DANGER

WHEN STORING THE HOLE DIGGER IN ANY ONE OF THE THREE CONFIGURATIONS, TURN THE FUEL TANK ON/OFF VALVE TO THE OFF POSITION TO MINIMIZE THE POSSIBILITY OF FUEL FLOODING THE CARBURETOR AND/OR ENTERING THE COMBUSTION CHAMBER AND/OR IMPACTING UPON THE ENVIRONMENT. SUCH AN OCCURRENCE CAN RESULT IN PROPERTY DAMAGE AND/OR PERSONAL INJURY.

ADDING AND REMOVING NONFLIGHTED AND FULL FLIGHTED AUGER EXTENSIONS.

APPLICATIONS: ALL MODELS.



CAUTION

While this text covers the use of all 300 Series Hole Diggers during the adding and removing of nonflighted and full flighted auger extensions, several variances exist between various models with the applicable engine start and stop procedures. Consult the applicable STARTING THE ENGINE WITH THE AUGER ATTACHED for specific information.

Many digging applications require a hole deeper than that provided by standard length augers. For such requirements, both nonflighted and full flighted auger

extensions are available. The nonflighted auger extension extends the digging depth by an additional 15 inches (381 mm). Full flighted auger extensions are available in diameters up to 12 inches (305 mm) and each with a standard 36 inch (914 mm) length.



CAUTION

Utilization of nonflighted and full flighted auger extensions requires additional operator experience, skill and common sense over that of an introductory or novice level of expertise. The manufacturer has no control over the experience, skill and common sense levels of each operator of the Hole Digger. Utilization of nonflighted and full flighted auger extensions requires the accumulation of *actual* hole digging experience, skill and common sense. Each operator must decide if his experience, skill and common sense level is sufficient to allow him to proceed with the utilization of nonflighted and full flighted auger extensions for any given and/or specific job application.

Follow this accepted procedure for utilizing both nonflighted and full flighted auger extensions to extend the digging depth:

- 1) Dig to the approximate full depth of the auger, utilizing the described operating instructions. Remove as much loose soil from the hole as possible with the auger rotating at a lower rotational speed.
- 2) STOP the engine and remove the auger from the hole. Disconnect the spark plug wire to prevent accidental engine starting. Close the fuel tank breather vent (if so equipped). Turn the fuel tank ON/OFF valve to the OFF position.
- 3) Disconnect and remove the Hole Digger from the auger. Reposition the auger in the hole. Attach the auger extension to the auger and secure with an auger pin. The Hole Digger can now be connected to the auger extension and secured with an auger pin. Reconnect the spark plug wire. FIGURE 58.
- 4) Follow the instructions outlined for starting and operating the Hole Digger. Use extra caution when starting the engine with the auger in the hole. Proceed to dig to the desired depth or to the full depth of the auger extension.
- 5) Use of the nonflighted auger extension to extend the digging depth is limited to one unit. For multiple use of full flighted auger extension, repeat the above procedure until the desired digging depth is achieved.



FIGURE 58



DANGER

NEVER UTILIZE MORE THAN ONE NONFLIGHTED AUGER EXTENSION TO INCREASE THE OVERALL DIGGING DEPTH. THE NONFLIGHTED AUGER EXTENSION IS NOT EQUIPPED WITH AUGER FLIGHTING TO ELEVATE THE LOOSE BORINGS FROM THE HOLE. CONSEQUENTLY, MULTIPLE USE OF NONFLIGHTED AUGER EXTENSIONS WILL ALLOW THE AUGER TO “BURY” ITSELF IN THE HOLE. SUCH USE CAN LEAD TO LOSS OF OPERATOR CONTROL AND PERSONAL INJURY WHILE DIGGING.

After the desired digging depth has been achieved, both nonflighted and full flighted auger extensions are removed by utilizing this accepted procedure:

- 1) Remove as much loose soil from the hole as possible with the auger rotating at an intermediate speed. STOP the engine and disconnect the spark plug wire to prevent accidental engine starting. Close the fuel tank breather vent (if so equipped). Turn the fuel tank ON/OFF valve to the OFF position.
- 2) Lift the auger extension(s)/auger and the Hole Digger up far enough out of the hole so that an auger extension is clear. Block the remaining auger/auger extension string with an auger fork to prevent it from falling back into the hole. An additional Crew Member will usually be required. Disconnect the Hole Digger from the auger extension(s)/auger. Store on the job site as outlined above. Remove the auger extension from the auger/auger extension string. FIGURE 59.



FIGURE 59

3) Disconnect the Hole Digger from the blocked auger extension(s)/auger string. Store the Hole Digger on the job site as outlined. Remove the auger extension that is clear of the hole from the auger extension(s)/auger string.

4) Reconnect the Hole Digger to the remaining auger extension(s)/auger string. Repeat the process until the lead auger is recovered.

5) Reconnect the engine spark plug wire.



DANGER

THE PROCEDURE OUTLINED FOR THE USE OF BOTH NONFLIGHTED AND FULL FLIGHTED AUGER EXTENSIONS OFFERS THE MOST ADAPTABLE METHOD OF EXTENDING THE DIGGING DEPTH FOR THE WIDEST CROSS SECTION OF PROBABLE OPERATORS. THIS PROCEDURE TAKES INTO ACCOUNT ANTICIPATED OPERATOR EXPERIENCE, SKILL AND COMMON SENSE. THE MANUFACTURER IS AWARE THAT NOT ALL OPERATORS WILL ELECT TO FOLLOW THIS PROCEDURE. THE MANUFACTURER HAS NO CONTROL OVER INDIVIDUAL OPERATING PROCEDURES AND/OR DECISIONS. MANY OPERATORS MAY ELECT TO UTILIZE THE NONFLIGHTED AUGER EXTENSION CONNECTED DIRECTLY TO THE AUGER AND BYPASS THE LONGER, MORE TIME CONSUMING PROCEDURE OUTLINED ABOVE. INDIVIDUAL OPERATORS MAY ELECT TO CHOOSE OTHER PROCEDURES IN AN EFFORT TO REDUCE THE ASSOCIATED PRODUCTION COSTS. THE RESULTING MACHINE

CONFIGURATIONS CAN PLACE THE HANDLES ALMOST LEVEL WITH (OR EVEN ABOVE) THE SHOULDERS OF THE OPERATORS. AT THIS HEIGHT LEVEL, THE HOLE DIGGER IS DIFFICULT TO CONTROL AGAINST POSSIBLE KICKBACK FORCES. THIS IS NOT A MANUFACTURER APPROVED PROCEDURE BECAUSE IT REQUIRES EACH POTENTIAL OPERATOR TO HAVE EXCEPTIONAL HEIGHT AND EXPERT WORK EXPERIENCE, SKILL AND COMMON SENSE. UNFORTUNATELY, THERE IS STILL NO REAL ASSURANCE THAT EACH AND EVERY OPERATOR WITH EXCEPTIONAL HEIGHT AND EXPERIENCE, SKILL AND COMMON SENSE CAN ALWAYS EXERCISE ADEQUATE CONTROL OF THE HOLE DIGGER TO GUARANTEE PERSONAL SAFETY. PERSONAL SAFETY CAN NEVER BE GUARANTEED FOR ANY GIVEN AND/OR SPECIFIC JOB APPLICATION FOR ANY TYPE OF POWERED EQUIPMENT. THE ACCEPTED PROCEDURE, AS OUTLINED IN THIS OPERATOR'S MANUAL, IS STRONGLY RECOMMENDED. THE MANUFACTURER CAN NOT CONDONE AND/OR APPROVE ANY OTHER PROCEDURE.

Service



DANGER

DO NOT PERFORM SERVICE AND/OR REPAIR RELATED FUNCTIONS WITH THE HOLE DIGGER MOUNTED TO THE 999 SERIES DISPLAY STANDS. THESE STANDS ARE NOT DESIGNED AND/OR INTENDED FOR THESE FUNCTIONS. SUCH USE CAN RESULT IN PROPERTY DAMAGE AND/OR PERSONAL INJURY.

CHANGING THE HOLE DIGGER TRANSMISSION OIL.

Applications: All models.

Tools Required:

- 1 each, small, adjustable wrench
- 1 each, small, clean funnel with a flexible extension spout

Changing the transmission oil will require a level working platform of sufficient size and appropriate height. As an alternative, the transmission driveshaft can be securely mounted in a suitable bench vise.

1) Change the transmission oil every 25 hours of operation, or more often as necessary, if the Hole Digger is operated in extremely dusty or dirty conditions.

2) Wipe any dust or dirt from the oil filler/level plug and oil drain plug areas of the transmission. The oil filler/level plug is located on the side of the transmission and is appropriately marked. The oil drain plug is located under the transmission. Remove both plugs with the adjustable wrench and allow the oil to completely drain from the transmission into a suitable container. Replace the oil drain plug and tighten securely with the adjustable wrench. Dispose of the used oil per accepted procedures.

3) Using the funnel, pour 1 US quart (0.94 lit) of General Equipment Company Transmission and Engine Oil, PNG 999-11, or a high grade, SAE 30 Detergent or 10W30 motor oil into the transmission through the oil filler/level plug opening. Use only an oil marked with an engine service classification SF, SG or SH/CD. The oil level in the transmission is to be maintained at the bottom of the oil filler/level plug hole. Allow any excess oil to drain out of the transmission. This procedure determines the correct oil level for the transmission. Correct oil level is important to ensure proper centrifugal clutch operation. Maintaining the oil level too high will cause excessive clutch slippage and result in high oil temperatures. Excessive slippage and high oil temperatures will significantly reduce the service life of the clutch assembly and affect the overall performance of the Hole Digger.

4) Replace the oil filter/level plug. Tighten securely with the adjustable wrench. Wipe off any excess oil spilled on the transmission. Dispose of the used oil properly.

5) Inspect the Hole Digger for loose, worn or damaged parts. Replace any questionable part or assembly with a genuine, approved factory replacement part only. Do not attempt any maintenance or repair work not described in the Operator Manual. Have such work performed at your dealer's servicing shop.

MAGURA® THROTTLE CONTROL MAINTENANCE PROGRAM.

Applications: All models.

The Magura twist grip throttle controls engine speed during the actual hole digging process. It has proven to be a rugged, dependable device that delivers exceptional service life while requiring only minimal maintenance. Every 8 hours of actual operation and whenever the throttle cable is replaced, the following maintenance program is to be followed:

1) Remove the aluminum cover to properly inspect the internal components. Any worn or damaged

component should be replaced with a factory approved replacement part only. FIGURE 60.

2) Normal use will produce a wear pattern by the braided inner cable into the idler pulley. Maximum allowable groove depth wear created by the throttle cable is 0.045 inch (1 mm). A wear depth in excess of this limit will require the replacement of the idler pulley.

3) Inspect the braided inner cable on a regular basis for excessive wear and fraying in the area in direct contact with the idler pulley. Abnormal wear or fraying will require the replacement of the throttle cable.



FIGURE 60

4) Inspect the barrel end of the braided inner cable for proper retention on a regular basis. A properly retained barrel end will have no relative movement between it and the inner cable. Any relative movement will require the replacement of the throttle cable. FIGURE 61.



FIGURE 61

5) Inspect the receptacle area of the throttle control which retains the barrel end of the braided inner cable on a regular basis. A properly fitted barrel fitting should have complete freedom of movement with no binding restrictions or excessive play due to wear. A barrel fitting which is binding within the receptacle should be discarded in favor of a replacement throttle cable. Excessive receptacle wear will require replacement of the specific component assembly. FIGURE 62.



FIGURE 62

6) The rubber boot assembly is designed to protect the internal components of the throttle control from excessive foreign material accumulations. The service life of the boot assembly can be extended with the application of an appropriate preservative on a regular basis.



CAUTION

Do not operate the Hole Digger without a rubber boot assembly in proper condition mounted in position on the Magura throttle control. Without the use of a proper rubber boot assembly, foreign materials can accumulate within the throttle control assembly. Such an occurrence can restrict the movement of the internal components, reducing operator control of the Hole Digger and result in property damage and/or personal injury.

7) Inspect the handle grip on a regular basis to determine it is properly secured to the throttle control. A grip which fits loose on the throttle control or has become worn or torn from use should be replaced with a factory approved replacement part only.

AUGER MAINTENANCE PROGRAM.

Applications: All models.

All General 300 Series Hole Diggers utilize earth augers incorporating the Pengo® type boring head configuration. This design has been field proven for several decades to provide unequaled digging performance in a wide range of unconsolidated and semiconsolidated soil formations. As with any ground engaging tool, the service life of the wear components will have limits directly affected by soil classification, soil moisture content and general operating procedures. A consistent auger maintenance program will provide maximum digging performance and investment return.

REPLACING A WORN AUGER SCREW BIT.

Applications: All augers.

Tools Required:

2 each, 1/2 inch wrenches.

Parts Required:

- 1 each, PN SB25 Screw Bit (for use with all augers with the exception of the 3 and 4 inch nominal diameter augers).
- 1 each, PN SB35 Screw Bit (for use with 3 inch nominal diameter earth auger).
- 1 each, PN SB45 Screw Bit (for use with 4 inch nominal diameter earth auger).

Note: Tungsten Carbide hardfaced versions (SB25C, SB35C and SB45C) of each applicable screw bit are available. A screw bit hardfaced with Tungsten Carbide will not increase the overall productivity rates of a specific auger equipped with the standard screw bit. The Tungsten Carbide hardfacing will substantially increase the anticipated service life of a screw bit.

1) The replacement of the auger screw bit will require a level working platform of sufficient size and appropriate height.

2) Inspect the auger for worn or broken components. Check to determine that the auger does not have a bent or damaged axle. A bent or damaged axle will cause the auger to "wobble" during use. Maximum allowable auger wobble is 0.25 inch (7 mm) total indicated runout (TIR). An auger with a total indicated runout wobble in excess of this value should be removed from service and scrapped.



DANGER

DO NOT OPERATE AN AUGER WHICH HAS A BENT OR DAMAGED AXLE WITH A TOTAL INDICATED RUNOUT EXCEEDING THE MAXIMUM ALLOWABLE LIMIT. EXCESSIVE AUGER WOBBLE CAN REDUCE OPERATOR CONTROL, RESULTING IN PROPERTY DAMAGE AND/OR PERSONAL INJURY.

3) Using the wrenches, remove the cap screw which restrains the screw bit to the drive lug. Remove the worn screw bit and properly dispose.

4) Inspect the drive lug for signs of excessive wear and damage. To replace the drive lug, it must be removed from the auger plate with either a suitable saw or cutting torch.

5) Install the replacement screw bit and retaining hardware to the drive lug. Hardware is unidirectional. Secure tight with the wrenches.

REPLACING WORN AUGER TEETH.

Applications: All augers 6 inch diameter and larger.

Tools Required:

- 1 each, 1/4 inch drift punch.
- 1 each, suitable safety glasses.
- 1 each, plastic hammer or,
- 1 each, soft type hammer specifically designed for impact use.

Parts Required:

- Required Quantity, 35 Standard Dirt Tooth or,
- Required Quantity, 35HFC Hardfaced Dirt Tooth or,
- Required Quantity, 5T30 Chisel Tooth or,
- Required Quantity, 5T30HFC Hardfaced Chisel Tooth, or
- Required Quantity, 1336 Tungsten Carbide Tooth.

Note: Augers utilized with the 300 Series Hole Diggers feature a wide variety of available tooth designs and configurations to increase their productivity rates and maximize service life during the digging process.

Teeth are forged from alloy steel and heat treated to extend their service life. All teeth incorporate the same retaining system and are fully interchangeable as far as their configuration and usage allow. Available teeth include the following:

35 Standard Dirt Tooth. For ordinary digging conditions. Thin cross section for fast penetration. Wears sharp. Install in all sockets of all boring heads. Service Life Factor: 1.

35HFC Tooth. Same as the 35 Standard Dirt Tooth with the exception of hardface material deposited on one side. Install with the hardface material facing up. Service Life Factor: 2 to 4.

5T30 Chisel Tooth. Helps rip through caliche, hardpan and other semiconsolidated soil formations. Install only in the inside sockets of boring heads with the rib facing up towards the drive hub. Not for use alone with 6 inch diameter augers. Its use increases the service life of other tooth configurations. Service Life Factor: 1.5.

5T30HFC. Same as the 5T30 Chisel Tooth with the exception of hardface material deposited on one side. Install with the hardface material facing up. Service Life Factor: 2 to 5.

1336 Tungsten Carbide Tooth. For use in extremely abrasive soil formations and frozen soils. Not for use in soil formations containing a high percentage of rock larger than the size of a golf ball. Its use in soil formations containing a large percentage of rock can result in chipping damage to the Tungsten Carbide inserts. Delivers extended service life over standard and hardfaced tooth configurations in most soil formations. Its use will not normally increase productivity rates over standard and hardfaced tooth configurations. Service Life Factor: 2 to 10.

1) The replacement of the auger teeth will require a level working platform of sufficient size and appropriate height. Wear safety eyewear and any other safety apparel deemed appropriate for the job application and/or job site environment.



DANGER

WEAR SAFETY EYEWEAR AND ANY OTHER SAFETY APPAREL DEEMED APPROPRIATE FOR THE JOB APPLICATION AND/OR JOB SITE ENVIRONMENT. THE TOOTH REPLACEMENT PROCESS CAN CREATE FLYING STEEL CHIPS AND/OR OTHER DEBRIS. CAUTION ALL ONLOOKERS REGARDING THE POSSIBILITY OF AND/OR TO REMAIN CLEAR OF FLYING DEBRIS. IMPROPER SAFETY PROCEDURES CAN RESULT IN PROPERTY DAMAGE AND/OR PERSONAL INJURY.

2) Using the hammer and drift punch, strike the visible end of the tooth located in the core print area with a

smooth movement. Repeat the action until the worn tooth become loose within the core print area of the casting. FIGURE 63.

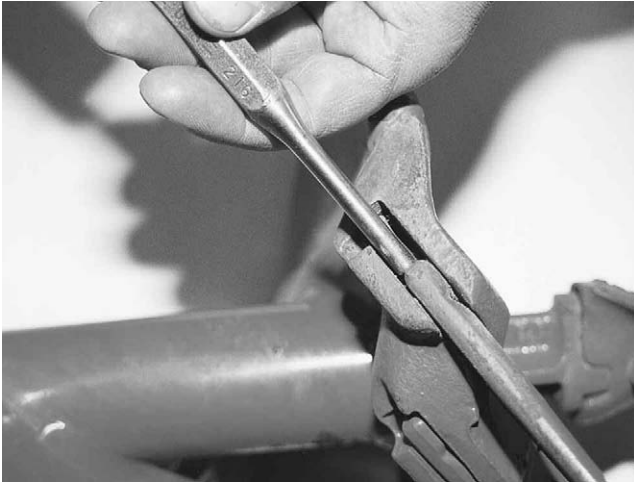

FIGURE 63

3) Remove the worn rubber lock from the core print area and properly dispose. Both solid, round and flat locking device configurations are utilized.

4) Inspect the core print area of the casting for excessive wear and/or damage. A core print area with excessive wear will not properly support a replacement tooth. Excessive wear is usually the indication that the auger has been worn past its useful service life and should be removed from service. An auger with excessive wear is depicted in FIGURE 64.



FIGURE 64

5) Lubricate the replacement rubber lock with water. Oil is not an acceptable lubricant. Install the solid, round type rubber lock into the hole in the core print area. The flat type locking device installs around the core

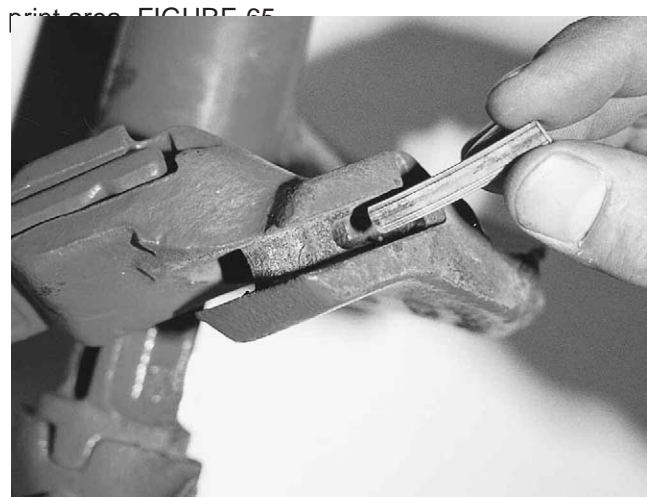

FIGURE 65

6) Install the replacement tooth into the core print area by striking the cutting edge of the tooth with the hammer. Use a smooth movement.



DANGER

DO NOT STRIKE ANY REPLACEMENT TOOTH DIRECTLY WITH A STEEL HAMMER. SUCH AN OCCURRENCE CAN CREATE FLYING STEEL CHIPS AND OTHER DEBRIS, RESULTING IN PROPERTY DAMAGE AND/OR PERSONAL INJURY. CAUTION ALL ONLOOKERS TO REMAIN CLEAR OF THE AREA WHEN PERFORMING AUGER MAINTENANCE.

7) Determine the replacement tooth is properly seated within the core print of the casting. Excessive casting wear will not properly seat a tooth, allowing it to fall loose and become lost.

ENGINE SERVICE.

Applications: All models.

Consult the applicable material supplied by the engine manufacturer for specific service and maintenance information regarding:

- 1) muffler
- 2) spark plug
- 3) air filter
- 4) carburetor adjustment
- 5) ignition timing
- 6) short and long term storage

Keep this information stored with the Operator Manual for the Hole Digger so it will always be available for use when the engine requires service or maintenance. A properly maintained engine will add considerably to the service life and overall productivity of the Hole Digger. If you require operation material for a specific engine utilized on a Hole Digger, contact the Customer Service Department. There is no charge for this service.

Under Title 13 of the California Code of Regulations, the California Air Resource Board (CARB) has identified several important engine service related subjects. The material supplied by the specific engine manufacturer will include the following information:

- 1) Statement of Compliance.
- 2) engine oil recommendations.
- 3) engine fuel recommendations.
- 4) maintenance information.
- 5) other information as required by the California Air Resource Board.
- 6) emission component warranty statement.

If you have any question regarding emission components, warranty rights and responsibilities for a specific engine utilized on a Hole Digger, contact the Customer Service Department for specific information. There is no charge for this service.

Troubleshooting

Applications: All models.

ENGINE

ENGINE FAILS TO START.

Ignition switch (if equipped) in OFF position. Place in ON position.

Ignition cut-off switch (if equipped) improperly adjusted. Adjust throttle cable.

Incorrect carburetor adjustment. See **Service** section.

Ignition wire to spark plug loose or disconnected. Reconnect.

Fuel supply exhausted. Refill fuel tank.

ENGINE LOSES POWER.

Incorrect carburetor adjustment. See **Service** section.

Water in fuel supply. Drain and replace fuel.

Plugged engine exhaust ports. See **Service** section.
Dirty spark plug. See **Service** section.

Incorrect throttle control/cable adjustment. See **Assembly** section.

Fuel tank breather vent closed (if so equipped). Open vent.

Dirty air filter. See **Service** section.

ENGINE OVERHEATS.

Incorrect carburetor adjustment. See **Service** section.

Incorrect fuel/oil mixture ratio (if powered by a 2 Cycle engine). See **Before Starting the Engine** section.

Cooling fins clogged with debris. Remove engine blower housing and clean cooling fins.

OPERATIONAL PROBLEMS.

HOLE DIGGER LACKS POWER.

Incorrect transmission oil level. See **Service** section.

Centrifugal clutch worn. See **Repair** section.

Auger diameter too large for given soil condition. See **Digging Operation** section.

Incorrect throttle control/cable adjustment. See **Assembly** section.

AUGER ROTATES AT IDLE SPEED.

Incorrect throttle control/cable adjustment does not permit proper engine idle speed. See **Assembly** section.

Centrifugal clutch worn. See **Repair** section.

Incorrect engine idle speed. See **Service** section.

Repair



DANGER

DO NOT PERFORM SERVICE AND/OR REPAIR RELATED FUNCTIONS WITH THE HOLE DIGGER MOUNTED TO THE 999 SERIES DISPLAY STANDS. THESE STANDS ARE NOT DESIGNED AND/OR INTENDED FOR MAINTENANCE FUNCTIONS. SUCH USE CAN RESULT IN PROPERTY DAMAGE AND/OR PERSONAL INJURY.

BASIC INFORMATION.

Applications: All models.

The 300 Series Hole Diggers utilize a fully enclosed, double reduction transmission for multiplying and transmitting engine torque to the auger. The principle involves engine horsepower and torque being transmitted through a centrifugal clutch and two sets of gear reductions into a final driveshaft. Oil is provided for lubrication and heat dissipation for the bearings, gears and clutch assembly.

The principal variance which exists between specific models occurs in five areas:

- 1) Engine configuration (2 or 4 Cycle).
- 2) Transmission cover configuration (2 or 4 Cycle).
- 3) Centrifugal clutch configuration (designed for either 2 or 4 Cycle engines).
- 4) Driveshaft configuration (General, Ground Hog or Stihl).
- 5) Primary gear configuration (2 or 4 Cycle). FIGURE 66.



FIGURE 66

Other major components are equally shared between all 300 Series Hole Diggers, including operator handles, throttle control, transmission case and bearings.

A pressure relief valve, PN 5677, is located on the top surface of the transmission cover to relieve any excess pressure created in the transmission due to heat rise. Should this valve become plugged, the following problems can occur:

- 1) The final driveshaft oil seal can push out of its housing, causing a loss of transmission oil.
- 2) The gasket that separates the two sections of the transmission can push out, causing a loss of transmission oil.

The potential for these problems can be minimized by cleaning the pressure relief valve at regular intervals.

Oil leakage between the final driveshaft and the oil seal is the result of the following problems:

- 1) The oil seal is worn due to extended operation.
- 2) The inner sealing lip of the oil seal is cut or nicked due to the admission of foreign material or some sharp, abrasive object.
- 3) A replacement oil seal was incorrectly installed in the transmission.

In all cases, a replacement oil seal must be correctly installed to prevent loss of transmission oil. The oil seal, a NATIONAL® PN 471820, is an industry interchange standard and can usually be obtained from local supply sources to help reduce downtime.

TRANSMISSION OIL SEAL REMOVAL AND INSTALLATION.

Applications: All models.

Tools Required:

1 each, small, adjustable wrench
2 each, 1/2 inch wrenches
1 each, torque wrench, 600 inch pounds (68 N.m.)
capacity with 1/2 inch and 15/16 inch sockets
or

1 each, torque wrench, 840 inch pounds (95 N.m.)
capacity with 1/2 inch and 1-7/16 inch sockets
1 each, 1/2 inch drive socket wrench with 15/16 inch
socket
or

1 each, 1/2 inch drive socket wrench with 1-7/16 inch
socket
1 each, plastic hammer
1 each, three jaw gear puller
1 each, shop press

Parts Required:

1 each, PN 310-0101 transmission gasket
1 each, PN 471820 National® oil seal or industry
equivalent
1 each, PN 15 alloy Woodruff key (if required)
1 each, PN 345-0332 final driveshaft (for Models 310,
310F, 330, 330B, 330T, if required)
1 each, PN 342-0330 final driveshaft (for Models 342F,
343B and 343T, if required)
1 each, PN 356-0330 final driveshaft (for Models 356F,
357B and 357T, if required)
1 each, PN 330H-0330 final driveshaft (for Model
330H, if required)
1 each, PN 343H-0330 final driveshaft (for Model
343H, if required)
1 each, PN 357H-0330 final driveshaft (for Model
357H, if required)
2 each, PN 08125 bearing cones (if required)
1 each, container of Barium or Lithium based,
lubricating grease
1 each, container of bearing & shaft locking grade,
anaerobic adhesive/sealant
1 each, container of wheel bearing grease

1) The repair of the Hole Digger will require a level working platform of sufficient size and appropriate height. As an alternative, the transmission driveshaft assembly can be securely mounted in a suitable bench vise.

2) Drain the fuel from the fuel tank and the remaining oil from the transmission. Refer to the **Service** section for more detailed information.

DANGER

GASOLINE IS AN EXTREMELY FLAMMABLE FUEL. USE EXTREME CAUTION WHEN HANDLING GASOLINE. DO NOT SMOKE OR BRING FIRE OR FLAME NEAR THE FUEL.

3) Using the plastic hammer, split and separate the transmission cover and case. Exercise caution not to damage the alignment dowel pins. Place the engine and transmission cover assembly in an upright position in a suitable area. Do not damage the throttle cable. Remove the primary gear and pinion gear assembly.

4) Clean the transmission case with an appropriate solvent.

CAUTION

Observe all applicable safety precautions for the solvent.

5) Remove the self-locking nut, PN 19100001 (if powered by a Subaru, Briggs & Stratton or Tecumseh engine) or PN 19160001 (if powered by a Honda engine), and flat washer, PN 17100000 (if powered by a Subaru, Briggs & Stratton or Tecumseh engine) or PNG 17160000 (if powered by a Honda engine).

6) Using the gear puller, remove the secondary gear, PNG 345-0350 from the driveshaft. Remove the Woodruff key, PN 15, and the Nilos ring, PN 08125/08231B-AV.

7) Using the shop press and suitable blocking, support the driveshaft housing area of the transmission case to prevent deformation damage. Press the driveshaft out of the transmission. The oil seal should also press out at this time. FIGURE 67.

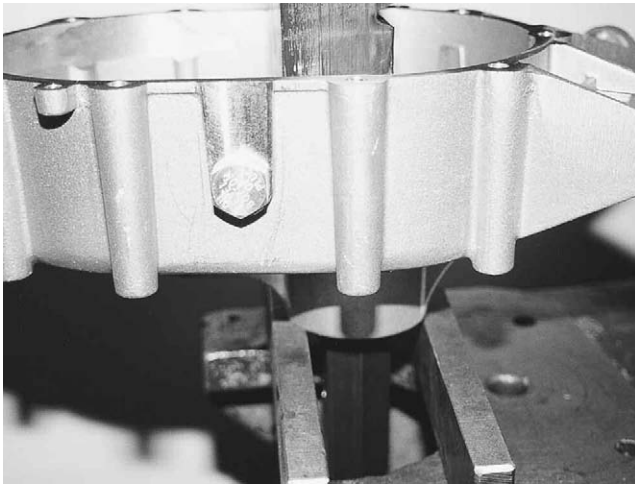

FIGURE 67



CAUTION

Wear safety glasses and other appropriate safety equipment when pressing the driveshaft assembly. Caution all onlookers about the possibility of flying debris and the potential for personal injury.

8) Remove the bearing cone, PNG 08125, from the shaft. Inspect the driveshaft for chipping or cracking around the Woodruff key area. If any damage is evident, replace the driveshaft.

9) Inspect the area where the oil seal rotates about the driveshaft for scratches, chips or other imperfections which can cause oil to leak past the oil seal. Unless the inner sealing member of the replacement oil seal turns on a concentric, smooth surface, it also will continue to leak oil. If the depth of the groove cut into the final driveshaft is greater than .010 inch (0.25 mm), the driveshaft must be replaced.

10) Inspect the replacement oil seal for cuts or other imperfections around the sealing members. Pack the cavity between the inner and outer sealing members with a Barium or Lithium based lubricating grease. LUBRIPLATE 105 is an approved lubricant. This precautionary measure minimizes the possibility of a dry oil seal rotating on a dry shaft during the first few minutes of operation. FIGURE 68.



FIGURE 68

11) Slide the oil seal over the circular spacer of the driveshaft with a circular, twisting motion. The crimped side of the oil seal, marked "NATIONAL 471820 USA" faces away and opposite the threaded end of the driveshaft. Use caution not to cut or nick the sealing lips when installing the oil seal.

12) Clean and inspect both bearing cones. Replace if excessive wear is evident. Repack both bearings with a suitable wheel bearing grease. Reinstall the lower bearing cone on the driveshaft against the spacer.

13) Clean and inspect the transmission oil seal housing for damage. If the housing shows signs of "galling" damage or elongation, coat the outside diameter of the oil seal with a bearing locking grade of anaerobic adhesive/sealant to help retain it in position.

14) Position the transmission case on the shop press with the driveshaft housing face up. Determine that the transmission case is not being supported by the alignment dowel pins. Use Service Tool PNG 345-7010, to press the oil seal/driveshaft assembly into the transmission until the oil seal is firmly seated against the machined shoulder. Cocking the seal in the housing contributes to oil seal failure. The tool is approximately 2.431 inches (61.7 mm) outside diameter. The inside diameter of the tool is approximately 2-1/4 inches. Apply the face of the service tool to the crimped bead of the oil seal, inasmuch as pressure too close to the center of the seal will distort or damage it. FIGURE 69.



FIGURE 69

If an arbor press is not available, the oil seal may be tapped in place with the same service tool or a thin, wooden block and plastic hammer. Take care to position the seal against the machined shoulder with the bore at right angles to the shaft. Cocking the seal in the housing contributes to oil seal failure. UNDER NO CIRCUMSTANCES SHOULD THE OIL SEAL RECEIVE DIRECT HAMMER BLOWS. FIGURE 70.



FIGURE 70

15) Reinstall the upper bearing cone, Nilos ring and Woodruff key on the final driveshaft. Coat the Woodruff key area of the driveshaft with light oil or with the Barium or Lithium based lubricant. Reinstall the secondary gear and flat washer.

16) Apply a small amount of anaerobic adhesive/sealant to the protruding threads of the final driveshaft. Torque the 5/8 inch self-locking nut (if equipped) to 40-50 foot pounds (54-68 N.m.). Torque

the 1-1/4 inch self-locking nut (if equipped) to 60-70 foot pounds (81-95 N.m). Check to determine the flat washer is tight against the secondary gear and it, in turn, is seated against the Nilos ring. If not fully seated, use a thin, wooden block and a plastic hammer to tap the gear down into place. UNDER NO CIRCUMSTANCES SHOULD THE SECONDARY GEAR RECEIVE DIRECT BLOWS FROM A STEEL HAMMER. Tap both ends of the driveshaft with a plastic hammer to help set the bearings. Loosen the 5/8 inch (if equipped), self-locking nut and retorque to 25 foot pounds (34 N.m.). Loosen the 1-1/4 inch self-locking nut (if equipped) and retorque to 60 foot pounds (81 N.m.). Again check to determine the flat washer is tight against the secondary gear. Tap both ends of the driveshaft with a plastic hammer to help set the bearings.

17) Attach the torque wrench and 15/16 inch socket to the 5/8 inch self-locking nut (if equipped) and rotate slowly. Attach the torque wrench and 1-7/16 inch socket to the 1-1/4 inch (if equipped) self-locking nut and rotate slowly. A MAXIMUM bearing drag of 30 INCH POUNDS (3.4 N.m.) is permitted. This value should allow a MAXIMUM of .003 inch (0.076 mm) freeplay in the bearings. A greater amount of bearing drag will significantly decrease the load capacity of the bearings and contribute to premature bearing failure. Adjust the torque value of the self-locking nut to yield a bearing drag within the allowable limit. THE FLAT WASHER MUST BE TIGHT AGAINST THE SECONDARY GEAR AND THE GEAR TIGHT AGAINST THE NILOS RING TO PREVENT DRIVESHAFT FREEPLAY THAT EXCEEDS THE ALLOWABLE LIMIT. If the bearing drag value is less than or greater than the 30 inch pound (3.4 N.m) figure readjust the self-locking nut torque value accordingly to help produce the desired value. FIGURE 71.



FIGURE 71



CAUTION

It is important to note that the precision machining tolerance between the driveshaft diameter and the secondary gear inside diameter can cause binding during assembly. This binding can prevent the gear from firmly seating against the Nilos ring and be the cause of excessive driveshaft freeplay.

18) Reinstall the primary gear and pinion assembly. If the existing transmission gasket is damaged, replace with PNG 310-0101 gasket. Realign the transmission dowel pins when reinstalling the engine and cover assembly. Torque all fasteners to 20 foot pounds (27 N.m.) in an "X" sequence.

19) Rotate the final driveshaft and check for excessive noise and/or binding. If excessive noise and/or binding is evident, disassemble the transmission and investigate for probable causes. Reassemble and retorque to the specified amount. Recheck again for excessive noise and/or binding.

20) Fill the transmission with oil. Refer to the Service section for the correct amount and type.

CENTRIFUGAL CLUTCH REMOVAL AND INSTALLATION.

Applications: 310 Hole Digger powered by the Kawasaki KT43 2 Cycle gasoline engine, 310F, 342F and 356F Hole Diggers powered by the Subaru EC10 Series 2 Cycle gasoline engine only.

The 310, 310F, 342F and 356F Hole Diggers utilize an all metal centrifugal clutch rotor and shoe assembly that expands with engine RPM to engage the clutch drum and transfer torque. The centrifugal clutch assembly is mounted to and operates concentrically about the engine crankshaft. Symptoms for replacement of the clutch assembly include the following:

- 1) Excessive clutch slippage and auger stalling at full, governed engine speed.
- 2) Partial clutch engagement (and resulting auger rotation) at the specified engine idle speed.

To replace the clutch assembly, proceed as follows:

Tools Required:

- 2 each, 1/2 inch wrenches
- 1 each, three jaw gear puller (if required)
- 1 each, plastic hammer
- 1 each, powered impact wrench with 9/16 inch socket

- 1 each, torque wrench, 240 inch pound (27 N.m.) capacity with 1/2 inch socket
- 1 each, 1 inch (25.4 cm) capacity micrometer
- 1 each, feeler gauge set

Parts Required:

- 1 each, PN 3016-1 drum and pinion assembly
- 1 each, PN 3017 rotor and shoe assembly
- 1 each, PN 11088 washer
- 1 each, PN 310-0101 transmission gasket (if required)
- 1 each, PN 8, alloy Woodruff key (if required)
- 1 each, container of high temperature, anti-seize compound

Centrifugal clutch removal and assembly will require a level working platform of sufficient size and appropriate height. As an alternative, the transmission driveshaft assembly can be securely mounted in a suitable bench vise.

- 1) Drain the fuel from the fuel tank and the oil from the transmission. Refer to the Service section for more detailed information.



DANGER

GASOLINE IS AN EXTREMELY FLAMMABLE FUEL. USE EXTREME CAUTION WHEN HANDLING GASOLINE. DO NOT SMOKE OR BRING ANY FIRE OR FLAME NEAR THE FUEL.

- 2) Split and separate the transmission cover and case. Exercise caution not to damage the dowel pins. Remove the primary gear and pinion assembly, PN 310-0340 and PNG 345-0310.
- 3) Clean the transmission case with an appropriate solvent.



CAUTION

Observe all applicable safety precautions for the solvent

- 4) Remove the self-locking nut, which retains the centrifugal clutch assembly to the engine crankshaft.
- 5) Remove the clutch drum and pinion assembly, PN 3016-1.
- 6) Remove the washer, PN 11088 and the clutch rotor and shoe assembly, PN 3017. Removal of the clutch rotor and shoe assembly may require the use of a gear puller.



CAUTION

If a gear puller is necessary to remove the PNG 3017 rotor and shoe assembly from the engine, exercise appropriate caution to minimize the occurrence of any structural damage to the rotor. Any structural damage to the rotor and shoe assembly will require its replacement. Wear safety eyewear and other, appropriate safety equipment. Caution all onlookers about the possibility of flying debris and the potential for personal injury.

7) Inspect the engine crankshaft and PN 8 Woodruff key for signs of cracks and other damage. Replace the Woodruff key if wear and/or elongation are visible. Measure the engine crankshaft with a micrometer. The minimum allowable crankshaft diameter is .5595 inch (14.2 mm). The maximum allowable TIR limit in the gear pinion journal area of the crankshaft is .003 inch (0.076 mm), relative to the crankshaft itself. Replace the crankshaft assembly if it is not within this established limit.

8) Clean the external threads on the crankshaft with an appropriate solvent.



CAUTION

Observe all applicable safety precautions for the solvent.

9) Install the replacement PN 3017 clutch rotor and shoe assembly in position on the engine crankshaft according to the information decal supplied. If the decal is missing or damaged, the rotor and shoe assembly can be installed by viewing the rotor. The rotor includes a hub assembly which is welded to the two cam levers. Install the larger shoulder diameter (which is welded to the cam levers) of the assembly facing toward the engine crankshaft. The smaller shoulder diameter will face up toward the threaded end of the crankshaft. Check to determine that the rotor hub is tight against the crankshaft shoulder and that the Woodruff key has not moved out of position. FIGURE 72.



FIGURE 72

10) Install the washer, PN 11088, on the engine crankshaft. Apply a small amount of high temperature, anti-seize compound to the pinion gear journal area of the crankshaft. Install the replacement PNG 3016 clutch drum and pinion assembly.

11) Install the retaining washer, PN AN960-716, and the self-locking nut, PN 19070001. Use the impact wrench to tighten the self-locking nut until the retaining washer bottoms out against the crankshaft step. This should yield approximately .031 inch (0.79 mm) axial free play between the pinion gear and the retaining washer. Axial freeplay limits for the clutch drum and pinion assembly on the engine crankshaft are: .015 inch (0.38 mm) minimum and .045 inch (1.1 mm) maximum. If the resulting axial freeplay is not within these limits, discard the drum and pinion assembly in favor of a replacement.

12) Check to determine that the clutch drum and pinion assembly rotates about the engine crankshaft freely and without contacting the clutch rotor and shoe assembly or transmission cover. If contact exists, remove the drum and pinion assembly and check for concentricity and/or warpage. A maximum of .015 inch (0.38 mm) TIR between the inside diameter of the pinion gear and the inside diameter of the clutch drum is allowed. If an excess amount is detected, discard the clutch drum and pinion assembly in favor of a replacement.

13) Reinstall the primary gear and pinion assembly. If the existing transmission gasket is damaged, replace with PNG 310-0101. Realign the transmission dowel pins when reinstalling the engine and cover assembly. Torque all fasteners to 20 foot pounds (27 N.m.) in an "X" sequence.

14) Rotate the final driveshaft and check for excessive noise and/or binding. If excessive noise and/or binding is evident, disassemble the transmission and investigate for probable causes. Reassemble and retorquer to the specified amount. Recheck again for excessive noise and/or binding.

15) Fill the transmission with oil. Refer to the **Service** section for the correct amount and type.

CENTRIFUGAL CLUTCH REMOVAL AND INSTALLATION.

Applications: 330, 330B, 343B and 357B Hole Diggers powered by Briggs & Stratton 4 Cycle gasoline engines, 330T, 343T and 357T Hole Diggers powered by the Tecumseh VLV60 4 Cycle gasoline engine only.

The 330, 330B, 330T, 343B, 343T, 357B and 357T Hole Diggers utilize an all metal centrifugal clutch rotor and shoe assembly that expands with engine RPM to engage the clutch drum and transfer torque. The centrifugal clutch assembly is mounted to and operates concentrically about the engine crankshaft. Symptoms for replacement of the clutch assembly include the following:

- 1) Excessive clutch slippage and auger stalling at full, governed engine speed.
- 2) Partial clutch engagement (and resulting auger rotation) at the specified engine idle speed.

To replace the clutch assembly, proceed as follows:

Tools Required:

- 2 each, 1/2 inch wrenches
- 1 each, three jaw gear puller (if required)
- 1 each, plastic hammer
- 1 each, powered impact wrench with 9/16 inch socket
- 1 each, torque wrench, 240 inch pound (27 N.m.) capacity with 1/2 inch socket
- 1 each, 1 inch (25.4 cm) capacity micrometer
- 1 each, feeler gauge set

Parts Required:

- 1 each, PN 3516 drum and pinion assembly
- 1 each, PN 3517 rotor and shoe assembly
- 1 each, PN 200682 washer
- 1 each, PN 310-0101 transmission gasket (if required)
- 1 each, PN 61, alloy Woodruff key (if required) for the Tecumseh VLV60 engine
- 1 each, PN 9, alloy Woodruff key (if required) for the Briggs & Stratton engine
- 1 each, container of high temperature, anti-seize compound

- 1 each, container of fastener retaining grade, anaerobic adhesive/sealant

Centrifugal clutch removal and installation will require a level working platform of sufficient size and capacity. As an alternative, the transmission driveshaft assembly can be securely mounted in a suitable bench vise.

- 1) Drain the fuel from the fuel tank, oil from the transmission and oil from the engine. Refer to the Service section for more detailed information.



GASOLINE IS AN EXTREMELY FLAMMABLE FUEL. USE EXTREME CAUTION WHEN HANDLING GASOLINE. DO NOT SMOKE OR BRING ANY FIRE OR FLAME NEAR THE FUEL.

- 2) Split and separate the transmission cover and case. Exercise caution not to damage the dowel pins. Remove the primary gear and pinion assembly, PNG 7034 and PN 345-0310.
- 3) Clean the transmission case with an appropriate solvent.



Observe all applicable safety precautions for the solvent

- 4) Remove the retaining cap screw and flat washer which retain the centrifugal clutch assembly to the engine crankshaft.
- 5) Remove the clutch drum and pinion assembly, PN 3516.
- 6) Remove the washer, PN 200682 and the clutch rotor and shoe assembly, PN 3517. Removal of the clutch rotor and shoe assembly may require the use of a gear puller.



If a gear puller is necessary to remove the PN 3517 rotor and shoe assembly from the engine, exercise appropriate caution to minimize the occurrence of any structural damage to the rotor. Any structural damage to the rotor and shoe assembly will require its replacement. Wear safety eyewear and other, appropriate safety equipment. Caution all

onlookers about the possibility of flying debris and the potential for personal injury.

7) Inspect the engine crankshaft and PN 61 or PN 9 Woodruff key for signs of cracks and other damage. Replace the Woodruff key if wear and/or elongation are visible. Measure the engine crankshaft with a micrometer. The minimum allowable crankshaft diameter is .7485 inch (19.0 mm). The maximum allowable TIR limit in the gear pinion journal area of the crankshaft is .003 inch (0.076 mm), relative to the crankshaft itself. Replace the crankshaft assembly if it is not within this established limit.

8) Clean the surface and internal threads of the crankshaft with an appropriate solvent.



CAUTION

Observe all applicable safety precautions for the solvent.

9) Install the replacement PN 3517 clutch rotor and shoe assembly in position on the engine crankshaft with the countersunk end of the bore toward the crankshaft shoulder. Check to determine the rotor hub is tight against the shoulder and the Woodruff key has not moved out of position. FIGURE 73.

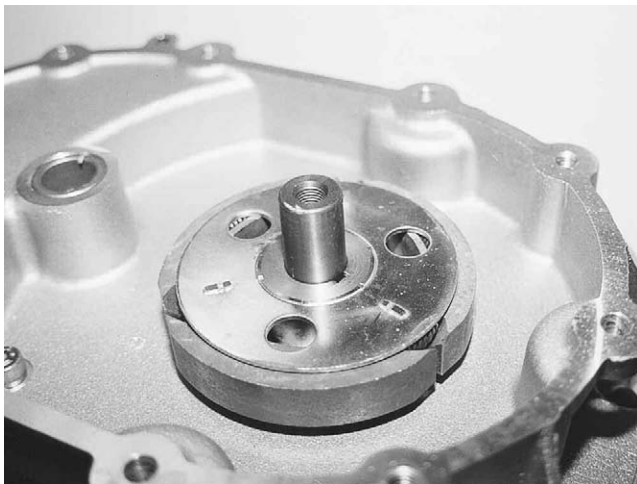

FIGURE 73

10) Install the washer, PN 200682, on the engine crankshaft. Apply a small amount of high temperature, anti-seize compound to the pinion gear journal area of the crankshaft. Install the replacement PNG 3516 clutch drum and pinion assembly.

11) Apply a few drops of anaerobic adhesive to the threads of the retaining cap screw, PN 15060800 and

install it and the retaining washer, PN 17060000. Use the impact wrench to tighten until the retaining washer bottoms out against the crankshaft. This should yield approximately .031 inch (0.79 mm) axial free play between the pinion gear and the retaining washer. Axial freeplay limits for the clutch drum and pinion assembly on the engine crankshaft are: .015 inch (0.38 mm) minimum and .045 inch (1.1 mm) maximum. If the resulting axial freeplay is not within these limits, discard the drum and pinion assembly in favor of a replacement.

12) Check to determine that the clutch drum and pinion assembly rotates about the engine crankshaft freely and without contacting the clutch rotor and shoe assembly or transmission cover. If contact exists, remove the drum and pinion assembly and check for concentricity and/or warpage. A maximum of .015 inch (0.38 mm) TIR between the inside diameter of the pinion gear and the inside diameter of the clutch drum is allowed. If an excess amount is detected, discard the clutch drum and pinion assembly in favor of a replacement.

13) Reinstall the primary gear and pinion assembly. If the existing transmission gasket is damaged, replace with PN 310-0101 gasket. Align the transmission dowel pins when reinstalling the engine and cover assembly. Torque all fasteners to 20 foot pounds (27 N.m.) in an "X" sequence.

14) Rotate the final driveshaft and check for excessive noise and/or binding. If excessive noise and/or binding is evident, disassemble the transmission and investigate for probable causes. Reassemble and retorque to the specified amount. Recheck again for excessive noise and/or binding.

15) Fill the transmission with oil. Refer to the **Service** section for the correct amount and type.

CENTRIFUGAL CLUTCH REMOVAL AND INSTALLATION.

Applications: 330H, 343H and 357H Hole Diggers powered by the Honda GXV140 4 Cycle gasoline engine only.

The 330H, 343H and 357H Hole Diggers utilize an all metal centrifugal clutch rotor and shoe assembly that expands with engine RPM to engage the clutch drum and transfer torque. The centrifugal clutch rotor and shoe assembly is mounted to and operates concentrically about the engine crankshaft. Symptoms for replacement of the clutch assembly include the following:

1) Excessive clutch slippage and auger stalling at full, governed engine speed.

2) Partial clutch engagement (and resulting auger rotation) at the specified engine idle speed.

To replace the clutch assembly, proceed as follows:

Tools Required:

- 2 each, 1/2 inch wrenches
- 1 each, three jaw gear puller (if required)
- 1 each, plastic hammer
- 1 each, torque wrench, 240 inch pound (27 N.m.) capacity with 1/2 inch socket
- 1 each, 1 inch (25.4 cm) capacity micrometer
- 1 each, feeler gauge set
- 1 each, 3/16 inch Allen wrench
- 1 each, 1/8 inch, long handle type Allen wrench

Parts Required:

- 1 each, PN 3516 drum and pinion assembly
- 1 each, PN 330H-0170 rotor and shoe assembly
- 1 each, PN 200682 plastic washer
- 1 each, PN 310-0101 transmission gasket (if required)
- 1 each, PN 6, alloy Woodruff key (if required)
- 1 each, container of high temperature, anti-seize compound
- 1 each, container of wicking grade, anaerobic adhesive

Centrifugal clutch removal and installation will require a level working platform of sufficient size and appropriate height. As an alternative, the transmission driveshaft assembly can be securely mounted in a suitable bench vise.

1) Drain the fuel from the fuel tank, oil from the transmission and oil from the engine. Refer to the **Service** section for more detailed information.

DANGER

GASOLINE IS AN EXTREMELY FLAMMABLE FUEL. USE EXTREME CAUTION WHEN HANDLING GASOLINE. DO NOT SMOKE OR BRING ANY FIRE OR FLAME NEAR THE FUEL.

2) Split and separate the transmission cover and case. Exercise caution not to damage the dowel pins. Remove the primary gear and pinion assembly, PN 7034 and PN 345-0310.

3) Clean the transmission case with an appropriate solvent.

CAUTION

Observe all applicable safety precautions for the solvent.

4) Using the 3/16 inch Allen wrench, remove the Allen screw from the side of the transmission cover. This will provide access for removing the centrifugal clutch rotor and shoe assembly. FIGURE 74.

5) Using the 1/8 inch Allen wrench, loosen the two set screws which retain the PN 330H-0170 rotor and shoe assembly to the engine crankshaft. Removal of the clutch rotor and shoe assembly may require the use of a gear puller. FIGURE 75.

CAUTION

If a gear puller is necessary to remove the PNG 330-0170 rotor and shoe assembly from the engine, exercise appropriate caution to minimize the occurrence of any structural damage to the rotor. Any structural damage to the rotor and shoe assembly will require its replacement. Wear safety eyewear and other, appropriate safety equipment. Caution all onlookers about the possibility of flying debris and the potential for personal injury.



FIGURE 74

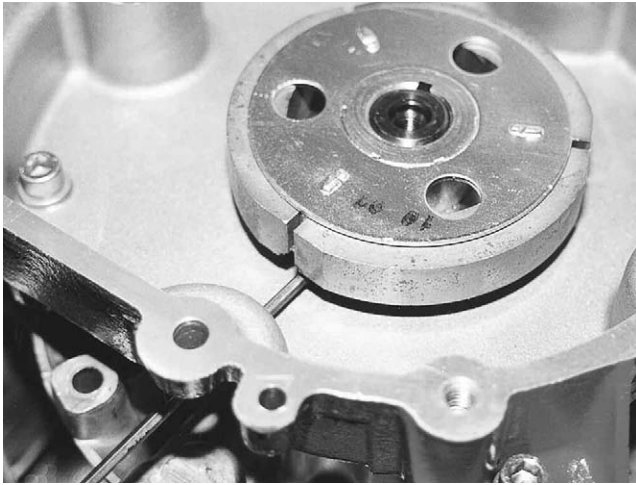

FIGURE 75

6) Remove clutch drum and pinion assembly, PN 3516 and washer, PN 200682, from the transmission driveshaft.

7) Inspect the engine crankshaft and PN 61 Woodruff key for signs of cracks and other damage. Replace the Woodruff key if wear and/or elongation are visible. Measure the engine crankshaft with a micrometer. The minimum allowable crankshaft diameter is .868 inch (22.0 mm). The maximum allowable TIR limit in the gear pinion journal area of the crankshaft is .003 inch (0.076 mm), relative to the crankshaft itself. Replace the crankshaft assembly if it is not within this established limit.

8) Clean the surface of the crankshaft with an appropriate solvent.



CAUTION

Observe all applicable safety precautions for the solvent.

9) Install the replacement PN 330-0170 clutch rotor and shoe assembly on the engine crankshaft with the hub, including the two set screws, toward the crankcase. Tighten with the 1/8 inch Allen wrench. FIGURE 75. The end of the crankshaft fits flush against the edge of the clutch rotor and shoe assembly. FIGURE 76.

10) Using the 3/16 inch Allen wrench, replace the Allen type access screw into the side of the transmission cover. Apply a wicking grade of anaerobic adhesive to the Allen screw. This will eliminate the screw from moving during operation of the Hole Digger.



FIGURE 76

11) Install the washer, PN 200682, on the transmission driveshaft. Apply a small amount of high temperature, anti-seize compound to the pinion gear journal area of the driveshaft. Install the replacement PN 3516 clutch drum and pinion assembly on the driveshaft.

12) Reinstall the primary gear and pinion assembly. If the existing transmission gasket is damaged, replace with PN 310-0101 gasket. Align the transmission dowel pins when reinstalling the cover. Torque all fasteners to 20 foot pounds (27 N.m.) in an "X" sequence.

13) Rotate the final driveshaft and check for excessive noise and/or binding. If excessive noise and/or binding is evident, disassemble the transmission and investigate for probable causes. Reassemble and retorque to the specified amount. Recheck again for excessive noise and/or binding.

14) Fill the transmission with oil. Refer to the Service section for the correct amount and type.

Storage

Applications: All models.

Proper procedure for long term storage of the Hole Digger will protect it against the affects of corrosion and damage. If the Hole Digger is not to be operated for a period of 30 days or more, proceed to store as follows:

1) Clean all accumulated dirt and grease from the Hole Digger utilizing an appropriate solvent.



CAUTION

Observe all applicable safety precautions for the solvent.

2) Follow the procedure as outlined in the material supplied by the engine manufacturer detailing long term storage of the engine.

3) Drain the transmission and refill with clean oil that is suitable for use when the Hole Digger will be next utilized.

4) Check all visible parts for wear, breakage or damage. Order any part required to make the necessary repair. This will avoid a needless delay when operating the Hole Digger at next use.

5) Apply a light coat of protective grease to the transmission driveshaft to prevent the formation of rust.

6) Do not store the Hole Digger connected to an auger. Always store the Hole Digger with the operator handles level with the ground. By not storing the Hole Digger in this configuration, transmission oil may drain from the breather vent and damage the surrounding environment. If the Hole Digger is powered by a 4 Cycle gasoline engine, this configuration will minimize the potential for crankcase oil entering the combustion chamber and creating a hydraulic lock up.

7) Close the fuel tank breather vent (if so equipped) to its maximum set position.

8) Turn the fuel ON/OFF valve to the OFF position.

9) Turn the ignition ON/OFF switch (if so equipped) to the OFF position.

10) Store the Hole Digger inside. If the Hole Digger must be stored outside, protect it and each auger with a suitable covering.

Specifications

Applications: 310F, 342F AND 356F Hole Diggers powered by the Subaru EC10V Series 2 Cycle gasoline engine only.

ENGINE

TYPE Subaru (Fuji Robin) EC10V
HIGH SPEED 4700 RPM (no load)

IDLE SPEED 1500 RPM
SPARK PLUG GAP .020 to .024 in (0.5 to 0.6 mm)

FUEL Unleaded (Regular grade is an acceptable substitute) grade gasoline and a high quality 2 cycle oil mixed in a 25:1 to 50:1 fuel to oil mixture ratio. Consult the material supplied by the engine manufacturer for specific information.

FUEL TANK CAPACITY 0.5 US gallon (1.9 lit)

GOVERNOR OIL CAPACITY 15 oz (150 cc)

GOVERNOR OIL SPECIFICATION SAE 30

TRANSMISSION

TYPE Enclosed, spur geared, double reduction

REDUCTION RATIO 32.5 to 1

OIL CAPACITY 1 US quart (0.94 lit)

OIL SPECIFICATION High quality motor oil classified for service SF, SG or SH/CD. Refer to **TRANSMISSION OIL RECOMMENDATIONS** for specific information.

CLUTCH 3-1/2 inch (89 mm) diameter, automatic cam type centrifugal

AUGER CAPACITY 2 inch (51 mm) diameter up to and including 18 inch (457 mm) diameter. Refer to **Digging Operation** for specific information.

GENERAL

REQUIRED NUMBER OF OPERATORS 2

LEAD AUGER SERIES General 4400 Series for Model 310F, General PSD Series for Model 342F and General BT360 Series for Model 356F.

AUGER EXTENSION SERIES General 5500 Series for Model 310F, General PSD Series for Model 342F and General BT360 Series for Model 356F.

Applications: 330B, 343B AND 357B Hole Diggers powered by the Briggs & Stratton 133702 4 Cycle gasoline engine only.

ENGINE

TYPE Briggs & Stratton 133702
HIGH SPEED 4000 RPM (no load)

IDLE SPEED 1600 RPM
SPARK PLUG GAP .030 inch (0.8 mm)

FUEL Unleaded (Regular grade is an acceptable substitute). Consult the material supplied by the engine manufacturer for specific information.

FUEL TANK CAPACITY 1.6 US quarts (1.5 lit)

TRANSMISSION

TYPE Enclosed, spur geared, double reduction

REDUCTION RATIO 25 to 1

OIL CAPACITY 1 US quart (0.94 lit)

OIL SPECIFICATION High quality motor oil classified for service SF, SG or SH/CD. Refer to **TRANSMISSION OIL RECOMMENDATIONS** for specific information.

CLUTCH 4 inch (102 mm) diameter, automatic type centrifugal

AUGER CAPACITY 2 inch (51 mm) diameter up to and including 18 inch (457 mm) diameter. Refer to **Digging Operation** for specific information.

GENERAL

REQUIRED NUMBER OF OPERATORS 2

LEAD AUGER SERIES General 4400 Series for Model 330B, General PSD Series for Model 343B and General BT360 Series for Model 357B.

AUGER EXTENSION SERIES General 5500 Series for Model 330B, General PSD Series for Model 343B and General BT360 Series for Model 357B

Applications: 330H, 343H and 357H Hole Diggers powered by the Honda GXV140 4 Cycle gasoline engine only.

ENGINE

TYPE HONDA GXV140GEN1

HIGH SPEED 3800 RPM (no load)

IDLE SPEED 1600 RPM

SPARK PLUG GAP .028 to .031 inch (0.7 to 0.8 mm)

FUEL Unleaded (Regular grade is an acceptable substitute) grade gasoline. Consult the material supplied by the engine manufacturer for specific information.

FUEL TANK CAPACITY 1.2 US quart (1.1 lit)

TRANSMISSION

TYPE Enclosed, spur geared, double reduction.

REDUCTION RATIO 25 to 1

OIL CAPACITY 1 US quart (0.94 lit)

OIL SPECIFICATION High quality motor oil classified for service SF, SG or SH/CD. Refer to **TRANSMISSION OIL RECOMMENDATIONS** for specific information.

CLUTCH 4 inch (102 mm) diameter, automatic type centrifugal

AUGER CAPACITY 2 inch (51 mm) diameter up to and including 18 inch (457 mm) diameter. Refer to **Digging Operation** for specific information.

GENERAL

REQUIRED NUMBER OF OPERATORS 2

LEAD AUGER SERIES General 4400 Series for Model 330H, General PSD Series for Model 343H and General BYT360 Series for Model 357H.

AUGER EXTENSION SERIES General 5500 Series for Model 330H, General PSD Series for Model 343H and General BT360 Series for **Model 357H.**

Applications: 330T, 343T and 357T Hole Diggers powered by the Tecumseh VLV60 4 Cycle gasoline engine only.

ENGINE

TYPE Tecumseh VLV60

HIGH SPEED 3800 RPM (no load)

IDLE SPEED 1600 RPM

SPARK PLUG GAP .030 inch (0.8 mm)

FUEL Unleaded (Regular grade is an acceptable substitute) grade gasoline. Consult the material supplied by the engine manufacturer for specific information.

FUEL TANK CAPACITY 1.5 US quart (1.4 lit)

TRANSMISSION

TYPE Enclosed, spur geared, double reduction.

REDUCTION RATIO 25 to 1

OIL CAPACITY 1 US quart (0.94 lit)

OIL SPECIFICATION High quality motor oil classified for service SF, SG or SH/CD. Refer to **TRANSMISSION OIL RECOMMENDATIONS** for specific information.

CLUTCH 4 inch (102 mm) diameter, automatic type centrifugal

AUGER CAPACITY 2 inch (51 mm) diameter up to and including 18 inch (457 mm) diameter. Refer to **Digging Operation** for specific information.

GENERAL

REQUIRED NUMBER OF OPERATORS 2

LEAD AUGER SERIES General 4400 Series for Model 330T, General PSD Series for Model 343T and General BT360 Series for Model 357T.

AUGER EXTENSION SERIES General 5500 Series for Model 330T, General PSD Series for Model 343T and General BT360 Series for Model 357T.

LEFT BLANK INTENTIONALLY

***Replacement Parts Diagrams
300 Series Hole Digger***

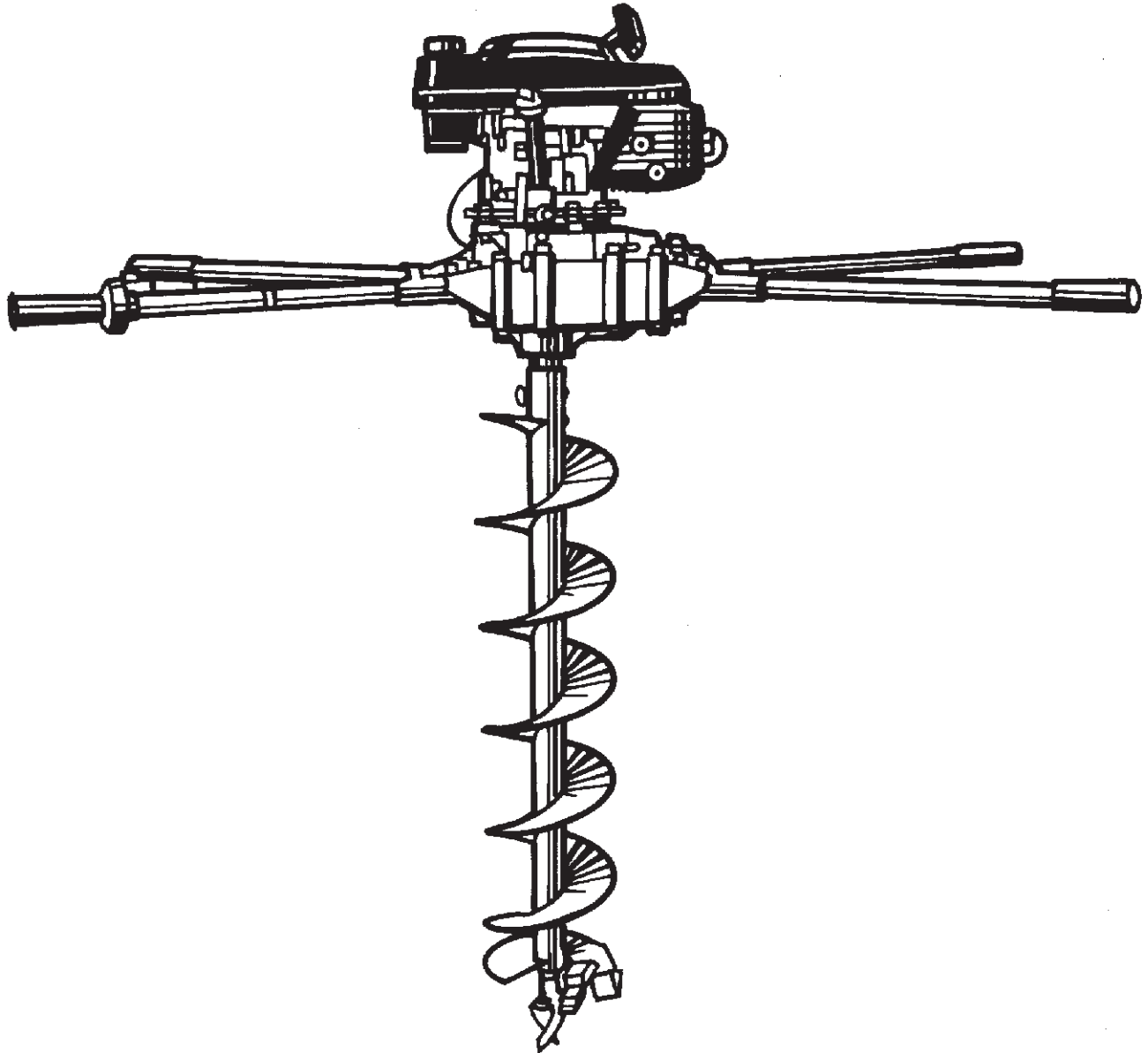

**Aluminum Body Series 312
Magura® Throttle Control Assembly
300 Series Hole Diggers**

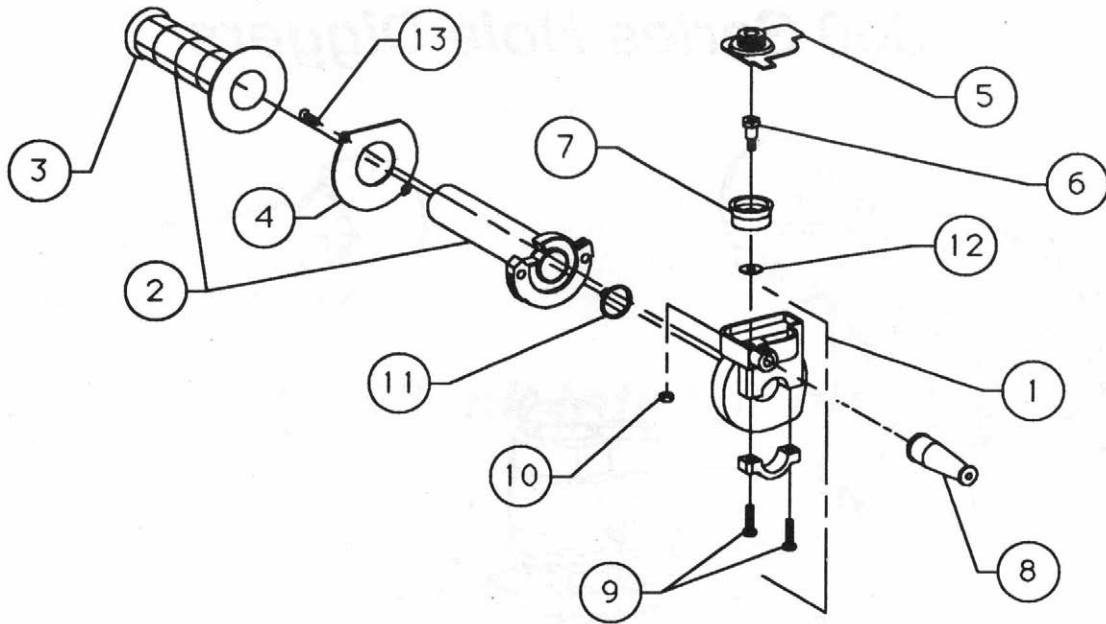

**Plastic Body Series 314
Magura® Throttle Control Assembly
300 Series Hole Diggers**

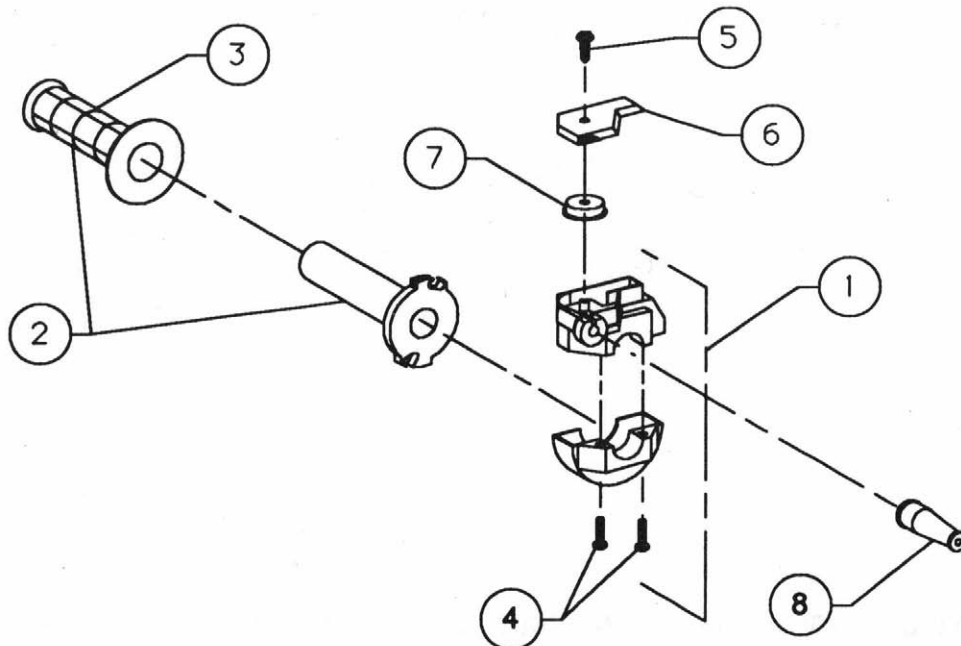

Aluminum Body Series 312
Magura® Throttle Control Assembly
300 Series Hole Diggers

Reference Number	PART NUMBER	DESCRIPTION	QUANTITY
1	310-0020-010-A	Body & Clamp, Throttle (Includes P/N 310-0020-100, Qty 2)	1
2	310-0020-020-A	Tube, Throttle (Includes P/N 310-0020-030)	1
3	310-0020-030	Grip, Handle	1
4	310-0020-040	Disc, Cover	1
5	310-0020-050	Cover, Aluminum	1
6	310-0020-060	Bolt, Axle	1
7	310-0020-070	Sheave, Roller	1
8	310-0020-080	Boot, Rubber	1
9	310-0020-100	Screw, Pan Head, M5 x 18	2
10	310-0020-110	Nut, Hexagon	1
11	310-0020-120	Washer, Insert	1
12	310-0020-130	Washer	1
13	310-0020-140	Screw	2

Plastic Body Series 314
Magura® Throttle Control Assembly
300 Series Hole Diggers

Reference Number	PART NUMBER	DESCRIPTION	QUANTITY
1	310-0030-010-A	Body Assembly, (Includes P/N 310-0030-040, Qty 2)	1
2	310-0030-020-A	Tube, Throttle (Includes P/N 310-0020-030)	1
3	310-0020-030	Grip, Handle	1
4	310-0030-040	Screw, Pan Head, M5 x 20	2
5	310-0030-050	Screw, Self Tapping	1
6	310-0030-060	Cover, Top	1
7	310-0030-070	Sheave, Roller	1
8	310-0020-080	Boot, Rubber	1

Operator Handle Assemblies 300 Series Hole Diggers

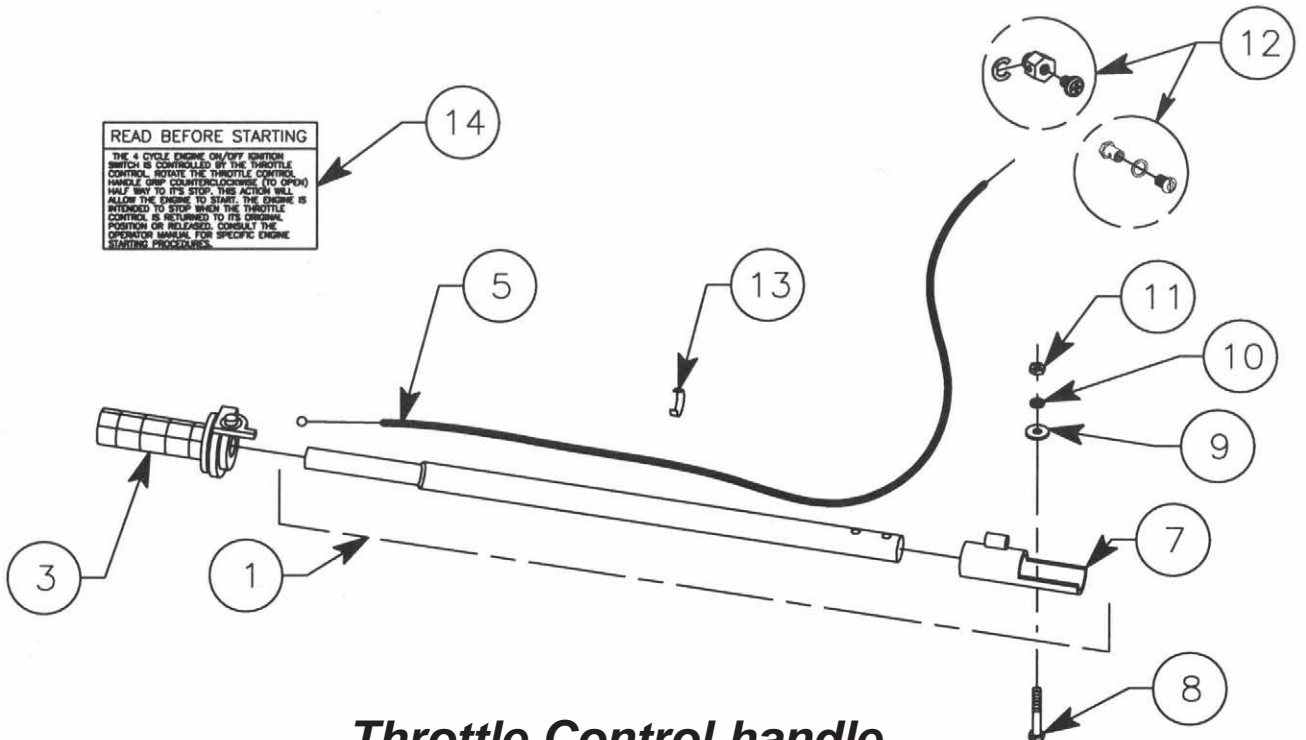

**Throttle Control handle
One Assembly Per Machine**

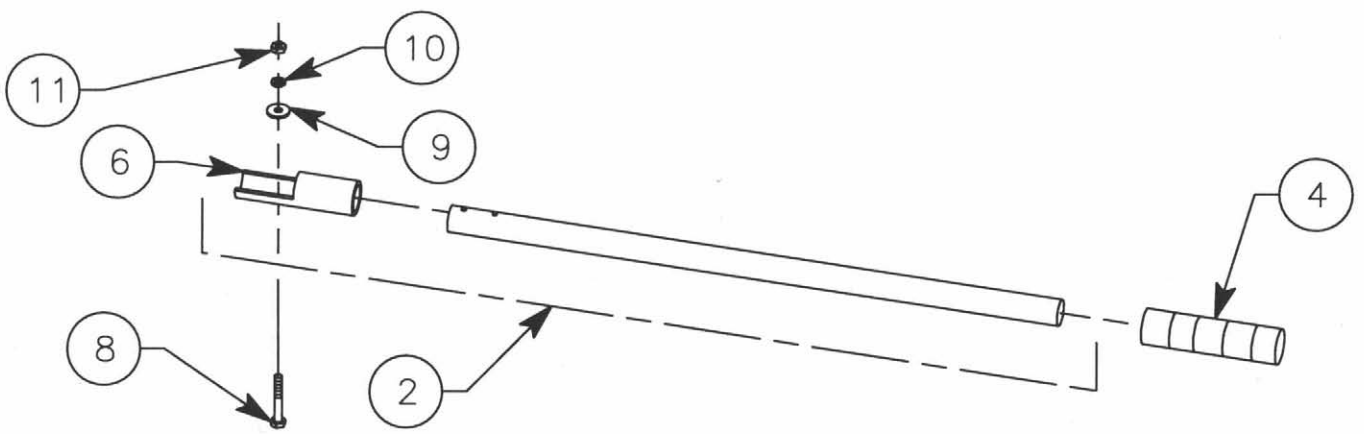

**Operator handle
Three Assemblies Per Machine**

Handle Assemblies

300 Series Hole Diggers

Reference Number	PART NUMBER	DESCRIPTION	QUANTITY
1	310-0091-A	Handle, Throttle (Includes P/N 310-0012)	1
2	310-0092-A	Handle, Operator (Includes P/N 310-0011 & P/N 330-0070)	3
3	310-0030	Throttle, Twist Control, Plastic, Complete	1
4	330-0070	Grip, Handle	3
5	310-0081	Cable, Throttle	1
6	310-0011	Tube, Handle Brace	3
7	310-0012	Tube, Handle Brace (Throttle)	1
8	15051800	Screw, Cap, 5/16" x 2-1/4" UNC, Grade 5, Plated	8
9	17040000	Washer, Flat, 1/4", Plated	8
10	16050000	Washer, Lock, 5/16", Plated	8
11	18050000	Nut, Hex, 5/16" UNC, Plated	8
12	WS-277	Assembly, Swivel	1
	330-0320	Assembly, Sivel (GXV160 Honda Engine Only)	1
13	CC-1	Clip, Throttle	1
14	330H-5040	Decal, Ignition (Used On Four Cycle Engines Only)	1

Engine And Cover Assembly 310F, 342F, & 356F Hole Diggers Equipped With Subaru EC10 Series Engine

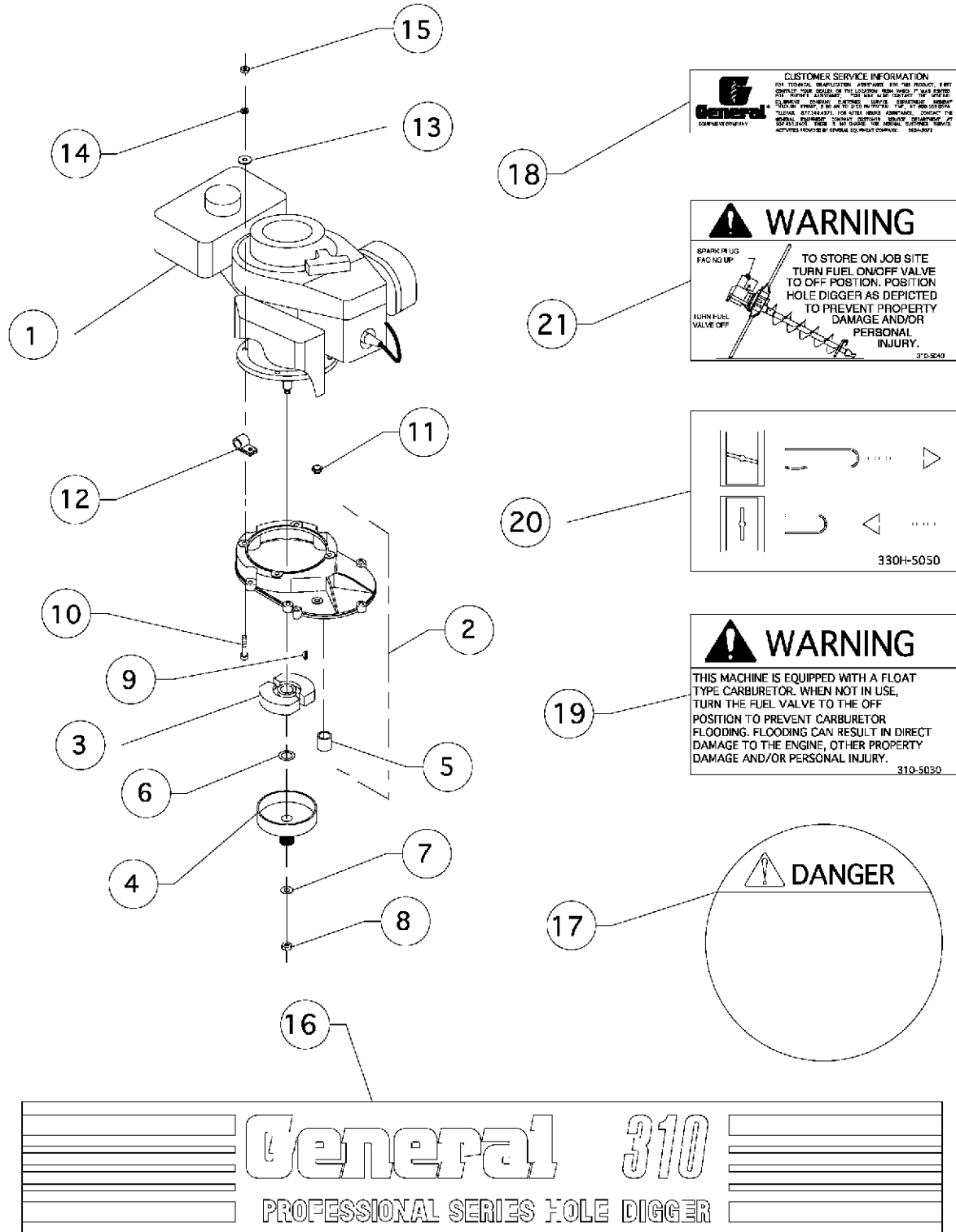

**Engine And Cover Assembly
310F, 342F, & 356F Hole Diggers
Equipped With Subaru EC10 Series Engine**

Reference Number	PART NUMBER	DESCRIPTION	QUANTITY
1	EC10-YV7100	Engine, Subaru (4 HP)	1
2	310-0132-A	Cover, Transmission (Includes P/N FES 2250-7)	1
3	3017	Rotor And Shoe Assembly, Clutch	1
4	3016-1	Drum And Pinion Assembly, Clutch	1
5	FES 2250-7	Bushing, Oilite®	1
6	11088	Washer, Fiber	1
7	AN-960-716	Washer, Flat, 7/16", Plain Finish	1
8	19070001	Nut, Jam Lock, 7/16" UNF	1
9	8	Key, Woodruff, 3/16" x 5/8", Alloy	1
10	60051100	Screw, Socket, 5/16" x 1 3/8" UNC, Plated	4
11	5677	Valve, Pressure Release	1
12	COV-0411	Clamp, Plated	1
13	AN-960-516L	Washer, AN Type, 5/16", Plated	4
14	16050000	Washer, Lock, 5/16", Plated	4
15	18050000	Nut, Hex, 5/16", Plated	4
16	310-5011	Decal, (Model 310F Only)	1
	342-5010	Decal, (Model 342F Only)	1
	356-5010	Decal, (Model 356F Only)	1
17	210-5020	Decal, Danger	1
18	SG24-5071	Decal Assistance	1
19	310-5030	Decal, Wrning	1
20	330H-5050	Decal, Chock	1
21	310-5040	Decal, Warning	1

Transmission Assembly 310F, 342F, 356F Hole Diggers Equipped With Subaru EC10 Series Engine

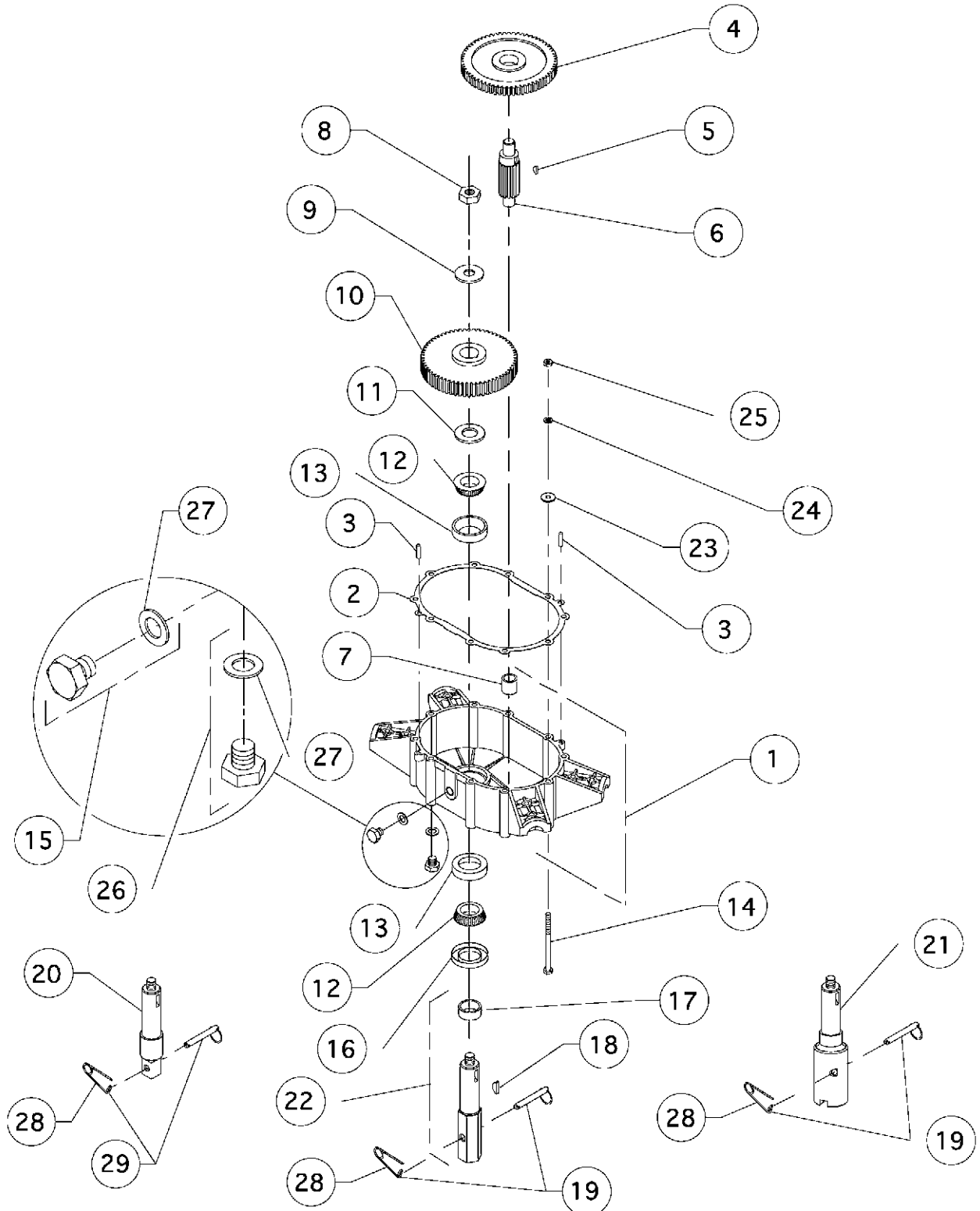

**Transmission Assembly
310F, 342F, 356F Hole Diggers
Equipped With Subaru EC10 Series Engine**

Reference Number	PART NUMBER	DESCRIPTION	QUANTITY
1	310-0121-A	Case, Transmission (Includes P/N A-1007-8 and 08231)	1
2	310-0101	Gasket, Transmission	1
3	51040800	Pin, Dowel 1/4" x 1"	2
4	310-0340	Gear, Primary	1
5	6	key, Woodruff, 5/32" x 5/8", Alloy	1
6	345-0310	Pinion	1
7	FES2250-7	Bushing, Oilite®	1
8	19100001	Nut, Hex, 5/8" UNF, Self-Locking	1
9	17100000	Washer, Flat, 5/8", Plain Finish	1
10	345-0350	Gear, Secondary	1
11	08125/08231B-AV	Ring, Nilos®	1
12	08125	Cone, Bearing	2
13	08231	Cup, Bearing	2
14	15053600	Screw, Cap, 5/16" x 4 1/2" UNC, Plated	10
15	50100801	Plug, Oil Level (Includes P/N 66044)	1
16	471820	Seal, Oil	1
17	345-0332-020	Bushing	1
18	15	Key, Woodruff, 1/4" x 1", Alloy	1
19	2121	Pin, Auger, General and Stihl (Includes P/N AP-21-S)	1
20	342-0332	Shaft, Drive, 7/8" Square, Ground Hog Type Drive, (P/N 345-0332-020 Not Required)	1
21	356F-0330	Shaft, Drive, Stihl Type Drive (P/N 345-0332-020 Not Required)	1
22	345-0332-A	Shaft, Drive, 1 3/8" Hexagon, 6 Sided, (Includes P/N 345-0332-020)	1
23	AN-960-516L	Washer, AN Type, 5/16", Plated	10
24	16050000	Washer, Lock, 5/16", Plated	10
25	18050000	Nut, Hex, 5/16" UNC, Plated	10
26	50100800	Plug, Oil Drain (Includes P/N 66044)	1
27	66044	Gasket, Oil Plug	2
28	AP-21-S	Pin, Safety	1
29	2021	Pin, Auger, Ground Hog (Includes P/N AP-21-S)	1

Engine And Cover Assembly 330H, 343H, & 357H Hole Diggers Equipped with Honda GXV140 Engine [Serial Ending with 33022418]

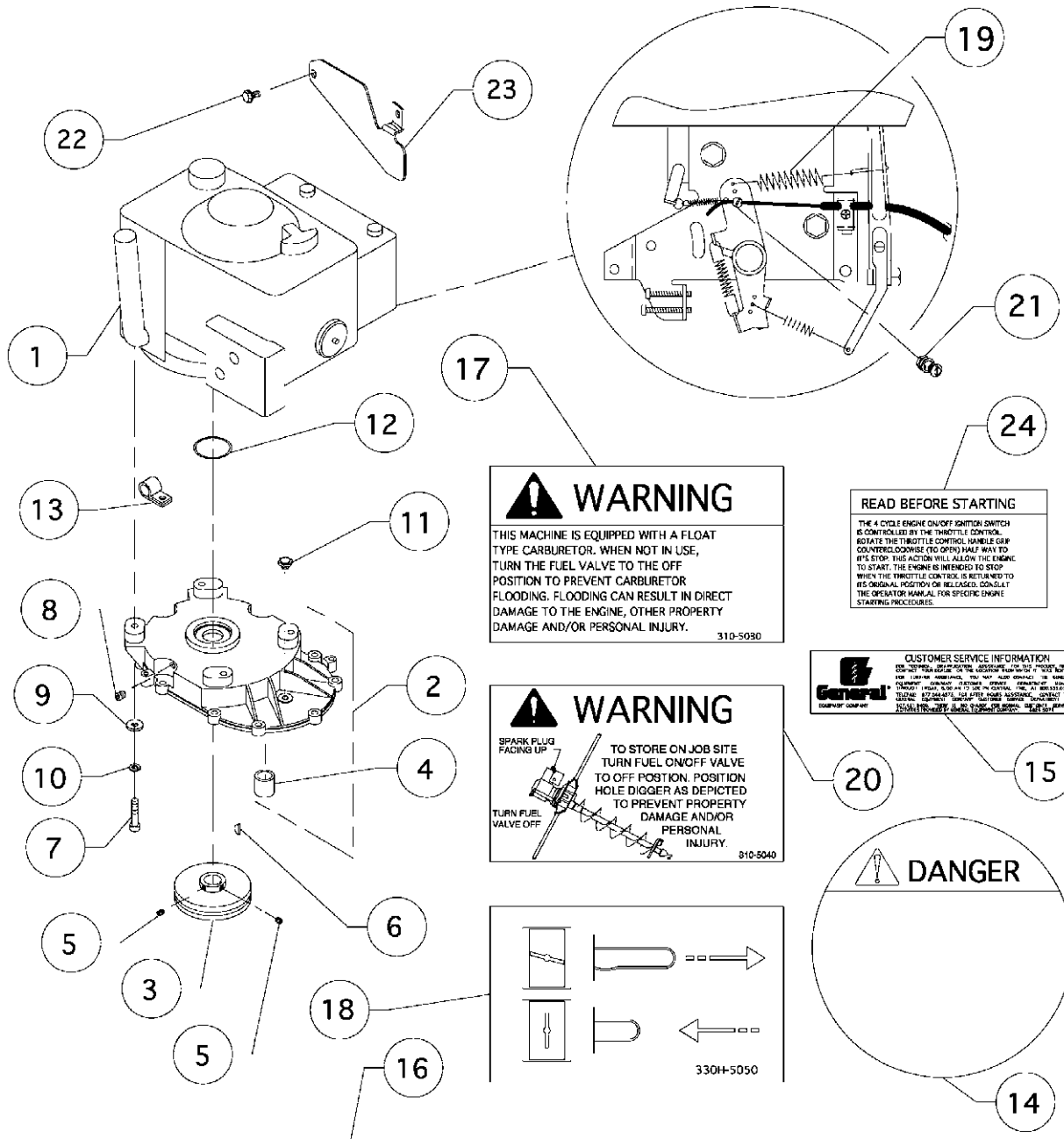

WARNING

THIS MACHINE IS EQUIPPED WITH A FLOAT TYPE CARBURETOR. WHEN NOT IN USE, TURN THE FUEL VALVE TO THE OFF POSITION TO PREVENT CARBURETOR FLOODING. FLOODING CAN RESULT IN DIRECT DAMAGE TO THE ENGINE, OTHER PROPERTY DAMAGE AND/OR PERSONAL INJURY.

310-5030

READ BEFORE STARTING

THE 4 CYCLE ENGINE ON/OFF IGNITION SWITCH IS CONTROLLED BY THE THROTTLE CONTROL. ROTATE THE THROTTLE CONTROL HANDLE GEAR COUNTERCLOCKWISE (TO OPEN) HALF WAY TO ITS STOP. THIS ACTION WILL ALLOW THE ENGINE TO START. THE ENGINE IS INTENDED TO STOP WHEN THE THROTTLE CONTROL IS RETURNED TO ITS ORIGINAL POSITION OR RELEASED. CONSULT THE OPERATOR MANUAL FOR SPECIFIC ENGINE STARTING PROCEDURES.

CUSTOMER SERVICE INFORMATION

FOR MORE INFORMATION, CONTACT YOUR LOCAL GENERAL EQUIPMENT COMPANY. FOR LARGER AREAS, YOU MAY ALSO CONTACT THE GENERAL EQUIPMENT COMPANY AT THE FOLLOWING ADDRESSES: GENERAL EQUIPMENT COMPANY, 10000 W. 10TH AVENUE, DENVER, CO 80202. TELE: 877-344-5454. SEE SPECIFIC ASSOCIATION CONTACT THE LOCAL EQUIPMENT COMPANY FOR MORE INFORMATION.

WARNING

TO STORE ON JOB SITE TURN FUEL ON/OFF VALVE TO OFF POSITION. POSITION HOLE DIGGER AS DEPICTED TO PREVENT PROPERTY DAMAGE AND/OR PERSONAL INJURY.

310-5040

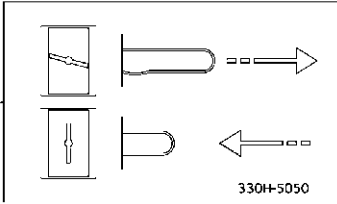

DANGER

14



**Engine And Cover Assembly
330H, 343H, & 357H Hole Diggers
Equipped with Honda GXV140 Engine
[Serial Ending with 33022418]**

Reference Number	PART NUMBER	DESCRIPTION	QUANTITY
1	GXV140N1GE	Engine, Honda (5 HP)	1
2	330-0134-A	Cover, Transmission (Includes P/N FES 2250-7)	1
3	330H-0170	Rotor And Shoe Assembly, Clutch	1
4	FES 2250-7	Bushing, Oilite®	1
5	31040201	Screw, Set, Cup, 1/4-28 x 1/4"	2
6	6	Key, Woodruff, 5/32" x 5/8", Alloy	2
7	60051401	Screw, Scocket, 5/16" x 1 3/4" UNF, Plateed	4
8	74020201	Plug, Pipe, 1/8-27 PTF	1
9	AN-960-516L	Washer, AN Type, 5/16", Plated	4
10	16050000	Washer, Lock, 5/16", Plated	4
11	5677	Valve, Pressure Release	1
12	330H-0050	"O" Ring	1
13	COV-0411	Clamp, Plated	1
14	210-5020	Decal, Danger	1
15	SG24-5071	Decal, Assistance	1
16	330-5011	Decal, (Model 330 Only)	1
	343-5010	Decal, (Model 343 Only)	1
	357-5010	Decal, (Model 357 Only)	1
17	310-5030	Decal, warning	1
18	330H-5050	Decal, Choke	1
19	330H-0400	Spring, Governor	1
20	310-5040	Decal, Warning	1
21	WS-277	Assembly, Swivel	1
22	88061010	Screw, Cap, Flange, M6 x 10mm	2
23	330H-0190	Guard, Governor Spring	1
24	330H-5040	Decal, Ignition	1

Engine And Cover Assembly 330H, 343H, & 357H Hole Diggers Equipped with Honda GXV160 Engine [Used Starting With Serial Number 33022419]

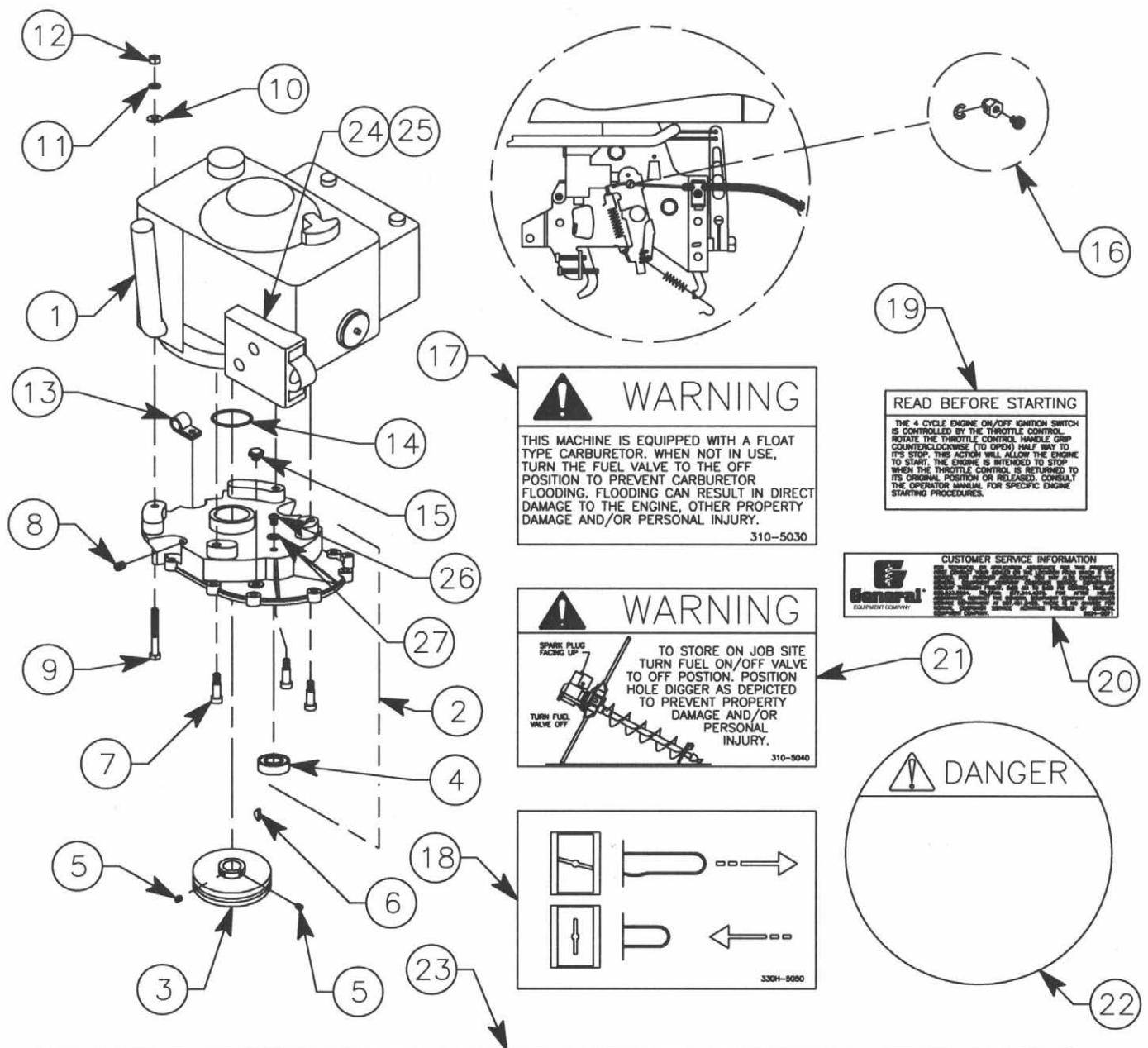

WARNING

THIS MACHINE IS EQUIPPED WITH A FLOAT TYPE CARBURETOR. WHEN NOT IN USE, TURN THE FUEL VALVE TO THE OFF POSITION TO PREVENT CARBURETOR FLOODING. FLOODING CAN RESULT IN DIRECT DAMAGE TO THE ENGINE, OTHER PROPERTY DAMAGE AND/OR PERSONAL INJURY.

310-5030

READ BEFORE STARTING

THE 4 CYCLE ENGINE ON/OFF IGNITION SWITCH IS CONTROLLED BY THE THROTTLE CONTROL. ROTATE THE THROTTLE CONTROL HANDLE GRIP COUNTERCLOCKWISE (TO OPEN) HALF WAY TO ITS STOP. THIS ACTION WILL ALLOW THE ENGINE TO START. THE ENGINE IS INTENDED TO STOP WHEN THE THROTTLE CONTROL IS RETURNED TO ITS ORIGINAL POSITION OR RELEASED. CONSULT THE OPERATOR MANUAL FOR SPECIFIC ENGINE STARTING PROCEDURES.

WARNING

TO STORE ON JOB SITE TURN FUEL ON/OFF VALVE TO OFF POSITION. POSITION HOLE DIGGER AS DEPICTED TO PREVENT PROPERTY DAMAGE AND/OR PERSONAL INJURY.

310-8040

CUSTOMER SERVICE INFORMATION

General EQUIPMENT COMPANY

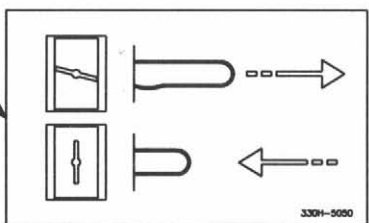

DANGER



**Engine And Cover Assembly
330H, 343H, & 357H Hole Diggers
Equipped with Honda GXV160 Engine
[Used Starting With Serial Number 33022419]**

Reference Number	PART NUMBER	DESCRIPTION	QUANTITY
1	GXV160-1100	Engine, Honda (5.5 HP)	1
2	330-0136-A	Cover, Transmission (Includes P/N 6203-2RS-12)	1
3	330H-0175	Rotor And Shoe Assembly, Clutch	1
4	6203-2RS-12	Bearing, Ball	1
5	31040201	Screw, Set, Cup, 1/4-28 x 1/4"	2
6	6	Key, Woodruff, 5/32" x 5/8", Alloy	1
7	62060601	Bolt, Shoulder, (3/8" x 3/4" x 5/16-24 UNF)	3
8	74020201	Plug, Pipe, 1/8-27 PTF	1
9	15051800	Screw, Cap, 5/16-18 UNC x 2-1/4", Plated	1
10	AN-960-516L	Washer, AN Type, 5/16", Plated	1
11	16050000	Washer, Lock, 5/16", Plated	1
12	18050000	Nut, Hexagon, 5/16", Plated	1
13	COV-0411	Clamp, Plated	1
14	330H-0020	"O" Ring	1
15	5677	Valve, Pressure Release	1
16	330-0320	Swivel Assembly	1
	310-0530	Decal, Danger	1
	330H-5030	Decal, Warning	1
17	330H-5040	Decal, Choke	1
18	SG24-5072	Decal, Ignition	1
19	310-5040	Decal, Assistance	1
20	210-5020	Decal, Danger	1
21	330-5011	Decal, (Model 330 Only)	1
22	343-5010	Decal, (Model 343 Only)	1
23	357-5030	Decal, (Model 357 Only)	1
24	330H-0310	Muffler (Modified)	1
25	330H-0340	Guard, Muffler (Modified)	1
26	37050300	Screw, Panhead, Philips, 5/16-18 UNC x 3/8", Plated	1
27	330H-0200	Washer, Plastic	1

Carburetor Assembly

330H, 343H, & 357H Hole Diggers

Equipped With Honda GXV140 Engine

This drawing represents various revisions of the BE35A carburetor in use as of this printing.
Unless otherwise specified all parts are interchangeable.

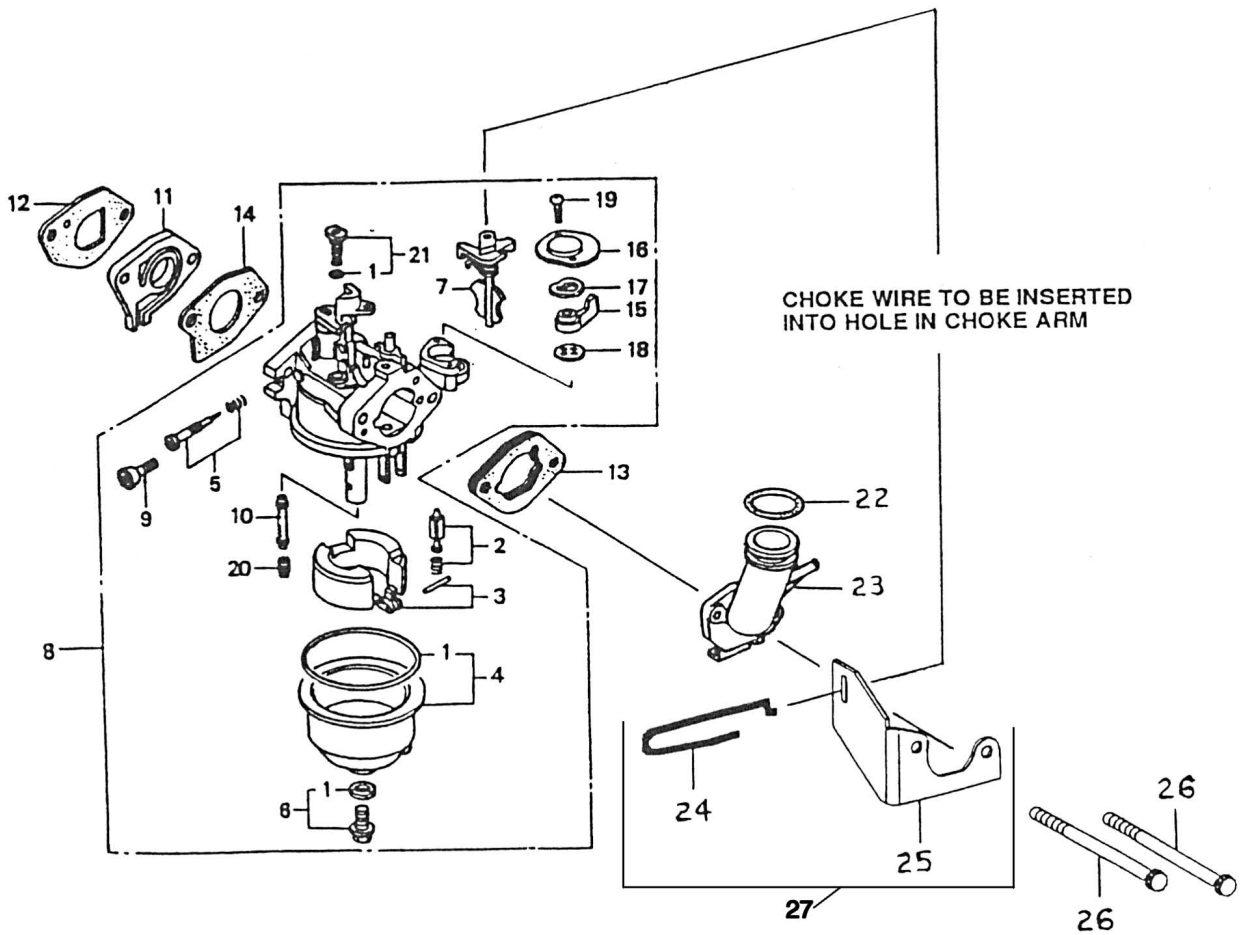

Carburetor Assembly
330H, 343H, & 357H Hole Diggers
Equipped with Honda GXV140 Engine

Reference Number	PART NUMBER	DESCRIPTION	QUANTITY
1	16010-ZG9-800	Gasket Set	1
2	16011-ZE0-005	Valve Set, Float	1
3	16013-ZE0-005	Float, Set	1
4	16015-ZG9-800	Chamber Set, Float	1
5	16016-ZH7-W01	Screw Set	1
6	16028-ZE0-005	Screw Set B	1
7	16045-ZE7-005	Choke Set	1
8	16100-ZG9-801	Carburetor Assembly (BE53A B)	1
	16100-ZG9-802	Carburetor Assembly (BE53A C)	1
9	16124-ZE0-005	Screw, Throttle Stop	1
10	16166-ZG9-801	Nozzle, Main	1
11	16211-ZG9-000	Insulator, Carburetor	1
12	16212-ZG9-T00	Gasket, Carburetor (HPE)	1
13	16220-ZE6-010	Spacer Comp., Carburetor	1
14	16221-ZG9-T00	Gasket, Carburetor	1
15	16953-ZE1-811	Lever, Valve	1
16	16954-ZE1-811	Plate, Lever Setting	1
17	16956-ZE1-811	Spring, Petcock Lever	1
18	16957-ZE1-812	Gasket Petcock	1
19	93500-03008-0G	Screw, Pan Head (3 x 8)	2
20	99101-ZH7-0520	Jet, Main (#52)	1 OPTIONAL
	99101-ZH7-0550	Jet, Main (#55)	1 OPTIONAL
	99101-ZH7-0580	Jet, Main (#58)	1
21	99204-ZE2-0380	Jet Set, Main (#38)	1
22	91301-ZG9-800	"O" -Ring (33.3 x 3.5)	1
23	17410-ZG9-800	Elbow Comp., Air Cleaner	1
24	16611-ZG9-U80	Rod, Choke Control	1
25	17954-ZG9-U80	Bracket, Choke Lever	1
26	95801-06100-00	Bolt, Flange (6 x 100)	2
27	330H-1000	Choke Conversion Kit GXV140 (Includes P/N s 16611-ZG9-U80 & 17954-ZG9-U80)	1

Transmission Assembly
330H, 343H, & 357H Hole Diggers
Equipped with Honda GXV140 Engine
[Serial Number Ending with 33022418]

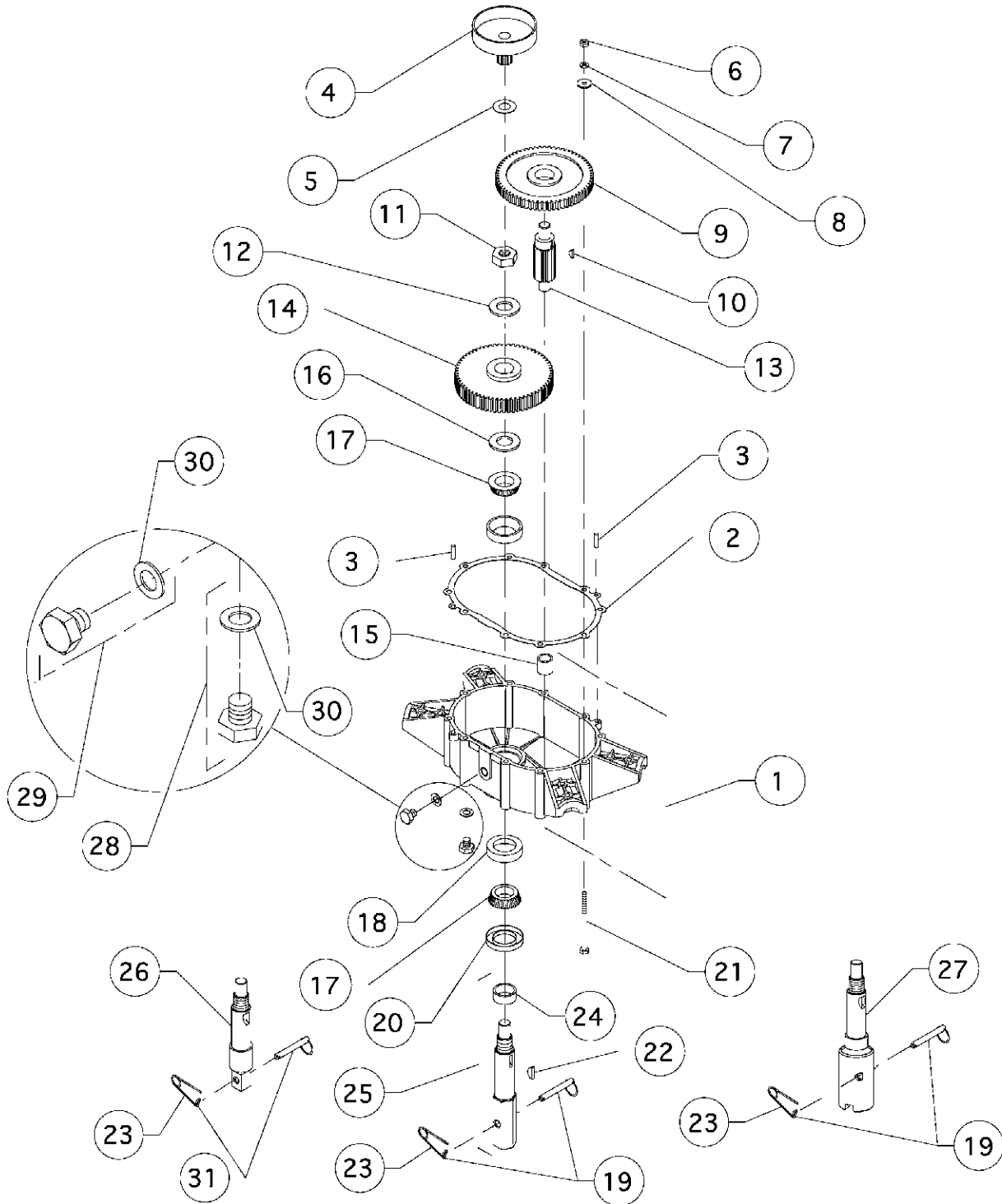

Transmission Assembly
330H, 343H, & 357H Hole Diggers
Equipped with Honda GXV140 Engine
[Serial Number Ending with 33022418]

Reference Number	PART NUMBER	DESCRIPTION	QUANTITY
1	310-0121-A	Case, Transmission (Includes P/N A-1007-8 and 08231)	1
2	310-0101	Gasket, Transmission	1
3	51040800	Pin, Dowel, 1/4" x 1	2
4	3516	Drum And Pinion Assembly, Clutch	1
5	200682	Washer, Fiber	1
6	18050000	Nut, Hex, 5/16" UNC, Plated	10
7	16050000	Washer, Lock, 5/16", Plated	10
8	AN-960-516L	Washer, AN Type, 5/16", Plated	10
9	7034	Gear, Primary	1
10	6	Key, Woodruff, 5/32" x 5/8", Alloy	1
11	19160001	Nut, Hex, 1"-14 UNF, Self-Locking	1
12	17160000	Washer, Flat, 1", Plain Finsh	1
13	345-0310	Pinion	1
14	345-0350	Gear, Secondary	1
15	FES2250-7	Bushing, Oilite®	1
16	08125/08231B-AV	Ring, Nilos®	1
17	08125	Cone, Bearing	2
18	08231	Cup, Bearing	2
19	2121	Pin, Auger, General and Stihl (Includes P/N AP-21-S)	1
20	471820	Seal, Oil	1
21	15053600	Screw, Cap, 5/16" x 4 1/2" UNC, Grade 5, Plated	10
22	15	Key, Woodruff, 1/4" x 1", Alloy	1
23	AP-21-S	Pin, Safety	1
24	345-0332-020	Bushing	1
25	330H-0330-A	Shaft, Drive, 1 3/8" Hexagon, 6 Side (Includes P/N 345-0332-020)	1
26	343H-0330	Shaft, Drive, 7/8" Square, Ground Hog Type Drive (P/N 345-0332-020 Not Required)	1
27	357H-0330	Shaft, Drive, Stihl Type Drive (P/N 345-0332-020 Not Required)	1
28	50100800	Plug, Oil Drain (Includes P/N 66044)	1
29	50100801	Plug, Oil Level (Includes P/N 66044)	1
30	66044	Gasket, Oil Plug	2
31	2021	Pin, Auger, Gound Hog (Includes P/N AP-21-S)	1

Transmission Assembly
330H, 343H, & 357H Hole Diggers
Equipped with Honda GXV160 Engine
[Starting With Serial Number 33022419]

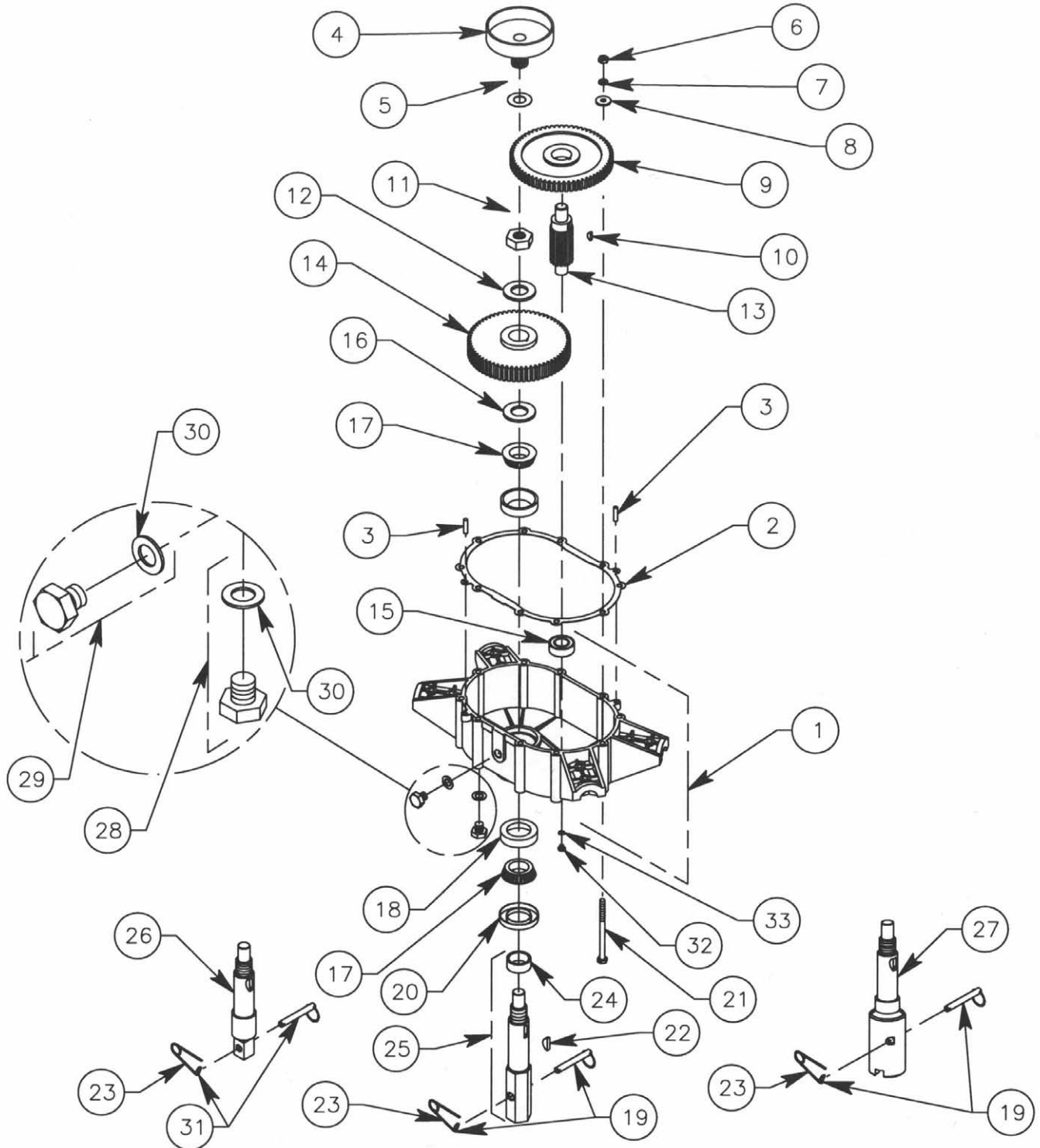

Transmission Assembly
330H, 343H, & 357H Hole Diggers
Equipped with Honda GXV160 Engine
[Starting With Serial Number 33022419]

Reference Number	PART NUMBER	DESCRIPTION	QUANTITY
1	310-0121-A	Case, Transmission (Includes P/N 6203-2RS-12 and 08231)	1
2	310-0101	Gasket, Transmission	1
3	51040800	Pin, Dowel, 1/4" x 1	2
4	3516	Drum And Pinion Assembly, Clutch	1
5	200682	Washer, Fiber	1
6	18050000	Nut, Hex, 5/16" UNC, Plated	10
7	16050000	Washer, Lock, 5/16", Plated	10
8	AN-960-516L	Washer, AN Type, 5/16", Plated	10
9	7034	Gear, Primary	1
10	6	Key, Woodruff, 5/32" x 5/8", Alloy	1
11	19160001	Nut, Hex, 1"-14 UNF, Self-Locking	1
12	17160000	Washer, Flat, 1", Plain Finsh	1
13	345-0310	Pinion	1
14	345-0350	Gear, Secondary	1
15	6203-2RS-12	Bearing, Ball	2
16	08125/08231B-AV	Ring, Nilos®	1
17	08125	Cone, Bearing	2
18	08231	Cup, Bearing	2
19	2121	Pin, Auger, General and Stihl (Includes P/N AP-21-S)	1
20	471820	Seal, Oil	1
21	15053600	Screw, Cap, 5/16" x 4 1/2" UNC, Grade 5, Plated	10
22	15	Key, Woodruff, 1/4" x 1", Alloy	1
23	AP-21-S	Pin, Safety	1
24	345-0332-020	Bushing	1
25	330H-0330-A	Shaft, Drive, 1 3/8" Hexagon, 6 Side (Includes P/N 345-0332-020)	1
26	343H-0330	Shaft, Drive, 7/8" Square, Ground Hog Type Drive (P/N 345-0332-020 Not Required)	1
27	357H-0330	Shaft, Drive, Stihl Type Drive (P/N 345-0332-020 Not Required)	1
28	50100800	Plug, Oil Drain (Includes P/N 66044)	1
29	50100801	Plug, Oil Level (Includes P/N 66044)	1
30	66044	Gasket, Oil Plug	2
31	2021	Pin, Auger, Gound Hog (Includes P/N AP-21-S)	1
32	37050300	Screw, Panhead, Philips, 5/16-18 UNC x 3/8", Plated	1
33	330H-0200	Washer, Plastic	1

Engine And Cover Assembly 330T, 343T, & 357T Hole Diggers Equipped with Tecumseh VLV60 Engine

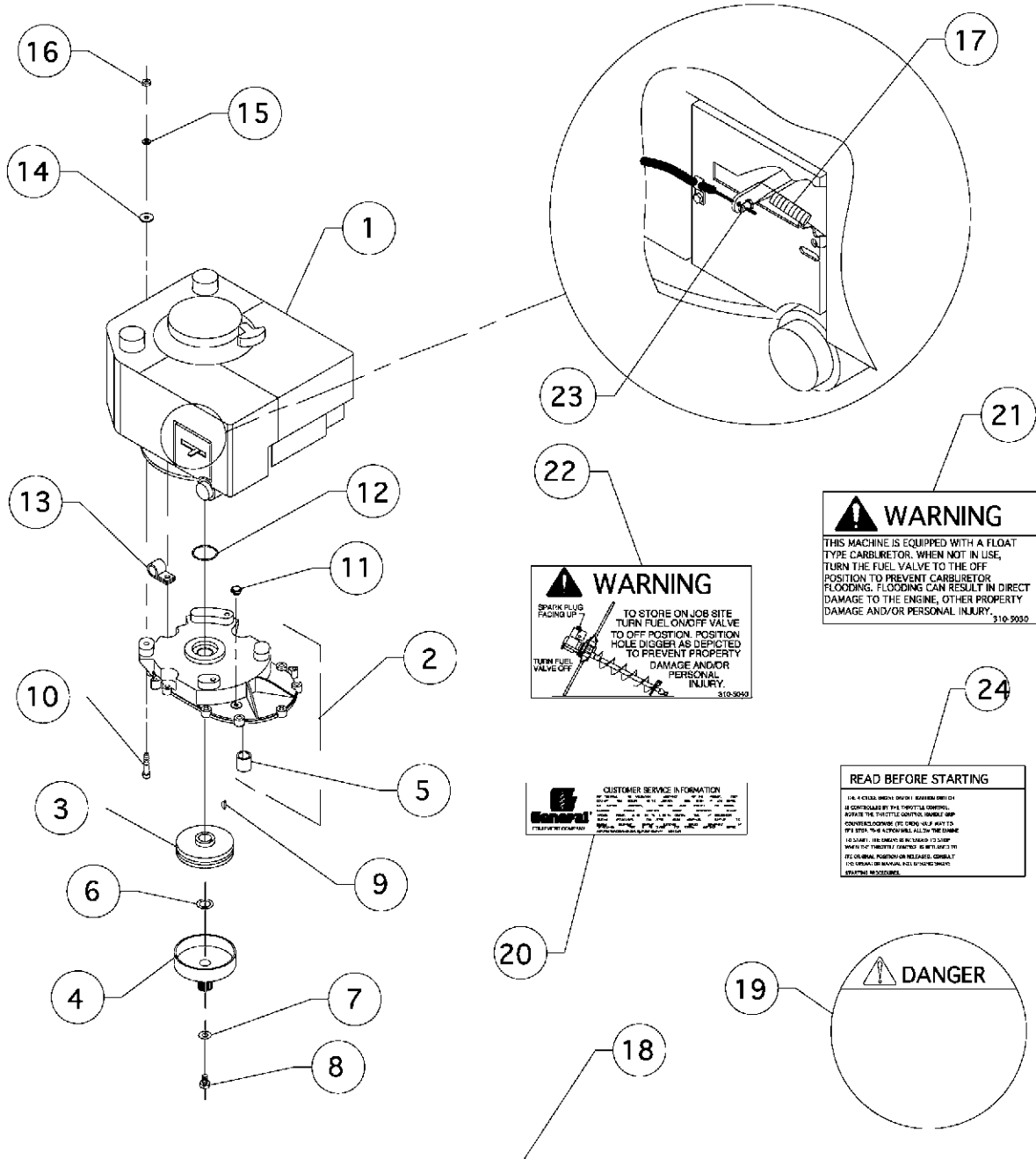

**Engine And Cover Assembly
330T, 343T, & 357T Hole Diggers
Equipped with Tecumseh VLV60 Engine**

Reference Number	PART NUMBER	DESCRIPTION	QUANTITY
1	VLV60-502052C	Engine, Tecumseh Vector (6 HP)	1
2	330-0135-A	Cover, Transmission (Includes P/N FES 2250-7)	1
3	3517	Rotor And Shoe Assembly, Clutch	1
4	3516	Drum And Pinion Assembly, Clutch	1
5	FES 2250-7	Bushing, Oilite®	1
6	200682	Washer, Fiber	1
7	17060000	Washer, Flat, 3/8", Plain Finish	1
8	15060401	Screw, Cap, 3/8-24 x 1/2 UNF	1
9	61	Key, Woodruff, 5/32" x 5/8", Alloy	1
10	60051600	Screw, Scoket, 5/16" x 2" UNC, Plated	3
11	5677	Valve, Pressure Release	1
12	330T-0050	"O" Ring	1
13	COV-0411	Clamp, Plated	1
14	AN-960-516L	Washer, AN Type, 5/16", Plated	3
15	16050000	Washer, Lock, 5/16", Plated	3
16	18050000	Nut, Hex, 5/16", Plated	3
17	330T-0300	Spring, Throttle Return	1
18	330-5011	Decal, (Model 330 Only)	1
	343-5010	Decal, (Model 343 Only)	1
	357-5010	Decal, (Model 357 Only)	1
19	210-5020	Decal, Danger	1
20	SG24-5071	Decal, Assistance	1
21	310-5030	Decal, Warning	1
22	310-5040	Decal, Warning	1
23	WS-277	Assembly, Swivel	1
24	330H-5040	Decal, Ignition	1

Transmission Assembly

330T, 343T, & 357T Hole Diggers

Equipped with Tecumseh VLV60 Engine

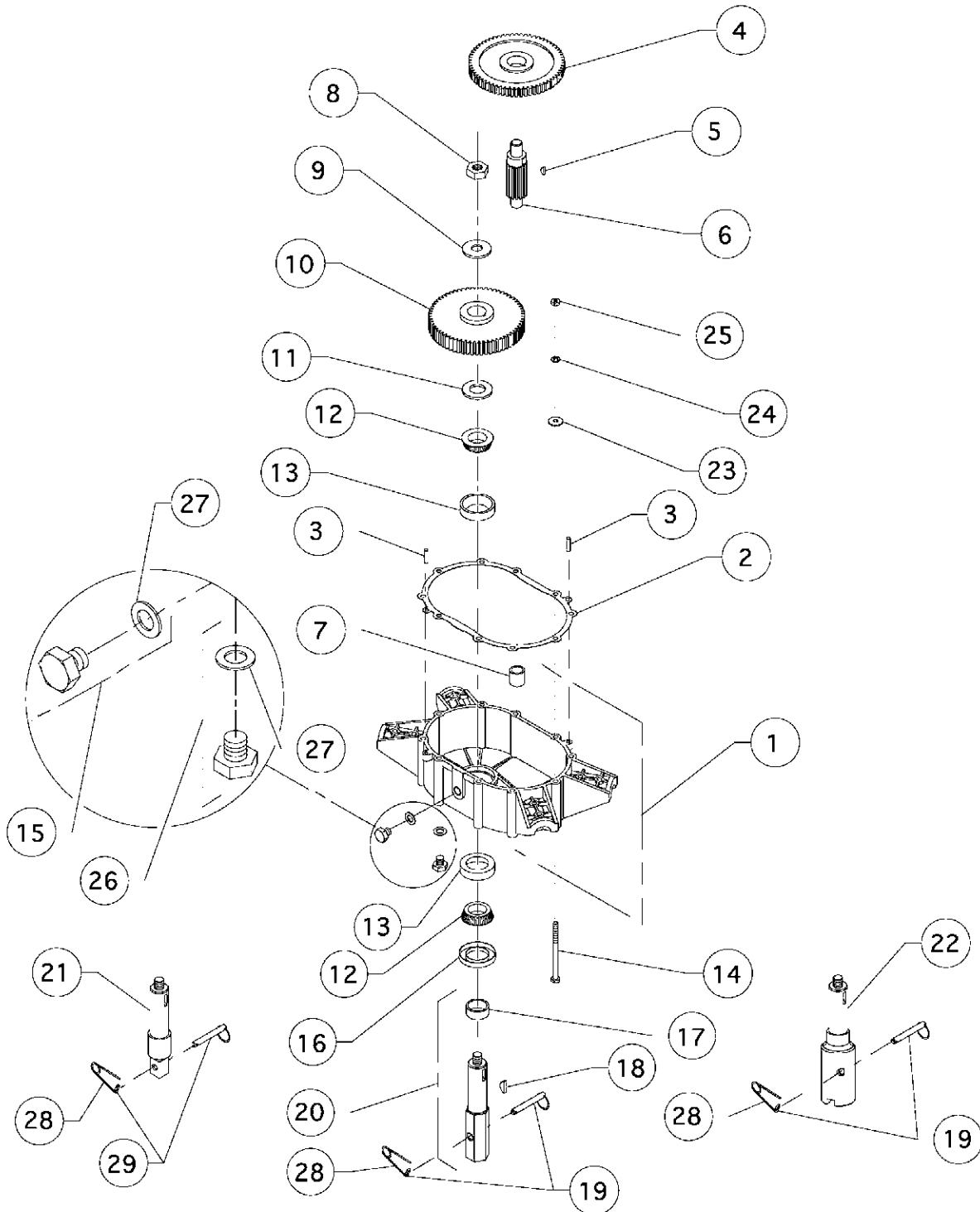

Transmission Assembly
330T, 343T, & 357T Hole Diggers
Equipped with Tecumseh VLV60 Engine

Reference Number	PART NUMBER	DESCRIPTION	QUANTITY
1	310-0121-A	Case, Transmission (Includes P/N A-1007-8 and 08231)	1
2	310-0101	Gasket, Transmission	1
3	51040800	Pin, Dowe 1/4" x 1"	2
4	7034	Gear, Primary	1
5	6	Key, Woodruff, 5/32" x 5/8", Alloy	1
6	345-0310	Pinion	1
7	FES2250-7	Bushing, Oilite®	1
8	19100001	Nut, Hex, 5/8" UNF, Self-Locking	1
9	17100000	Washer, Flat, 5/8", Plain Finish	1
10	345-0350	Gear, Secondary	1
11	08125/08231B-AV	Ring, Nilos®	1
12	08125	Cone, Bearing	2
13	08231	Cup, Bearing	2
14	15053600	Screw, Cap, 5/16" x 4 1/2" UNC, Grade 5, Plated	10
15	50100801	Plug, Oil Level (Includes P/N 66044)	1
16	471820	Seal, Oil	1
17	345-0332-020	Bushing	1
18	15	Key, Woodruff, 1/4" x 1" Alloy	1
19	2121	Pin, Auger, General and Stihl (Includes P/N AP-21-S)	1
20	345-0332-A	Shaft, Drive, 1 3/8" Hexagon, 6 Sided (Includes P/N 345-0332-020)	1
21	345-0332	Shaft, Drive, 7/8" Square, Ground Hog Type Drive (P/N 345-0332-020 Not Required)	1
22	356F-0330	Shaft, Drive, Stihl Type Drive (P/N 345-0332-020 Not Required)	1
23	AN-960-516L	Washer, AN Type, 5/16", Plated	10
24	16050000	Washer, Lock, 5/16", Plated	10
25	18050000	Nut, Hex, 5/16" UNC, Plated	10
26	50100800	Plug, Oil Drain (Includes P/N 66044)	1
27	66044	Gasket, Oil Plug	2
28	AP-21-S	Pin, Safety	1
29	2021	Pin, Auger, Ground Hog (Includes P/N AP-21-S)	1

Replacement Parts Diagrams
4400 Series Earth Augers
1-3/8" Hexagon Drive Connection
For Use With 310/330 Series Hole Diggers

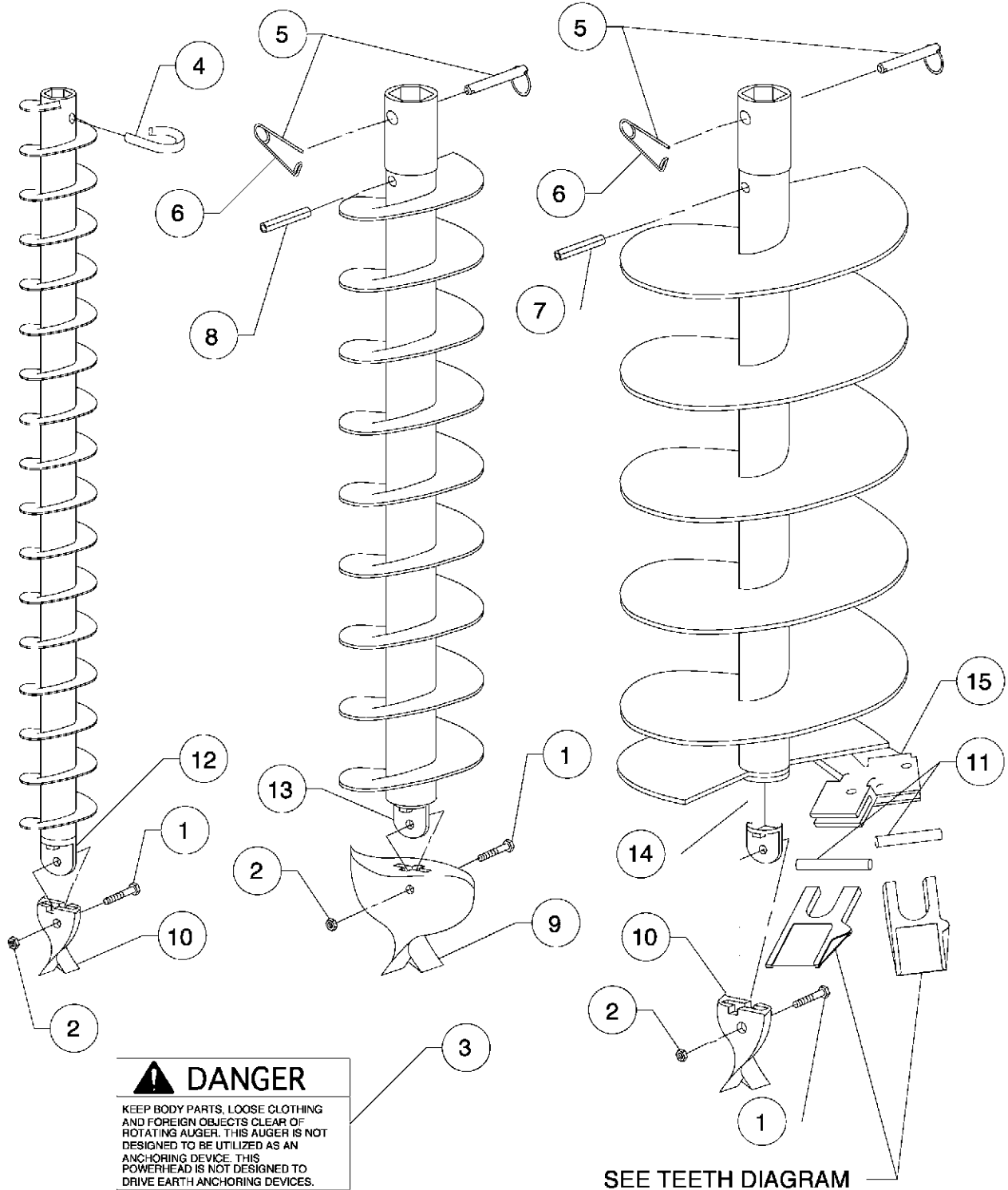

Replacement Parts Diagrams
4400 Series Earth Augers
1-3/8" Hexagon Drive Connection
For Use With 310/330 Series Hole Digger

Reference Number	PART NUMBER	DESCRIPTION	APPLICATION	QUANTITY
1	15051200	Screw, Cap, 5/16" x 1 1/2" UNC, Plated	All Augers	1
2	18050000	Nut, Hex, 5/16" UNC, Plated	All Augers	1
3	233-5092	Decal, Danger	All Augers	1
4	DP-2	Pin, Drive	4400-2E3 Auger	1
			5500-2X3 Extension	1
	DP-3	Pin, Drive	4400-3E3 Auger	1
			4410-4E3 Auger	1
			5500-3X3 Extension	1
			5510-4X3 Extension	1
5	2121	Pin, Auger (Includes P/N AP-21-S)	4400-4E3 thru 4400-18P Augers	1
			5500-15X Extension	1
			5500-4E3 thru 5500-12E3 Extensions	1
6	AP-21-S	Pin, Safety	4400-4E3 thru 4400-18P Augers	1
			5500-15X Extension	1
			5500-4E3 thru 5500-12E3 Extensions	1
7	20052000	Pin, Roll, 5/16" x 2-1/2", Plain Finish	4400-12E3 thru 4400-18P Augers	1
			5500-12X3 Extension	1
8	20051600	Pin, Roll, 5/16" x 2", Plain Finish	4400-4E3 thru 4400-10E3 Augers	1
			5500-4X3 thru 5500-10X3 Extensions	1
			5500-15X Extension	1
9	SB35	Bit, Screw	4400-3E3 Auger	1
	SB45	Bit, Screw	4400-4E3 and 4410-4E3 Augers	1
10	SB25	Bit, Screw	4400-2E3 Auger	1
			4400-6E3 thru 4400-18P Augers	1
11	RL	Lock, Rubber	4400-6E3 thru 4400-18P Augers	As Req

Replacement Parts Diagrams
4400 Series Earth Augers
1-3/8" Hexagon Drive Connection
For Use With 310/330 Serive Hole Diggers

Reference Number	PART NUMBER	DESCRIPTION	APPLICATION	QUANTITY
12	140S	Lug, Drive (Weld On)	4400-2E3 Auger	1
13	141M	Lug, Drive (Weld On)	4400-3E3 Auger	1
			4400-4E3 and 4410-4E3 Augers	1
14	140CS	Lug, Drive (Weld On)	4400-6E3 thur 4400-18P Augers	1
15	6CS	Shank, 6" (Weld On)	4400-6E3 Auger	1
			4400-16E3 and 4400-18P Augers	1
	8CS	Shank, 8" (Weld On)	4400-8E3 Auger	1
	12CS	Shank, 12" (Weld On)	4400-10E3 and 4400-12E3 Augers	1
			4400-16E3 and 4400-18P Augers	2

Left Blank Intentionally

Replacement Parts Diagrams
PSD Series Earth Augers
7/8" Square (Ground Hog) Drive Connection
For Use With 342/343 Series Hole Diggers

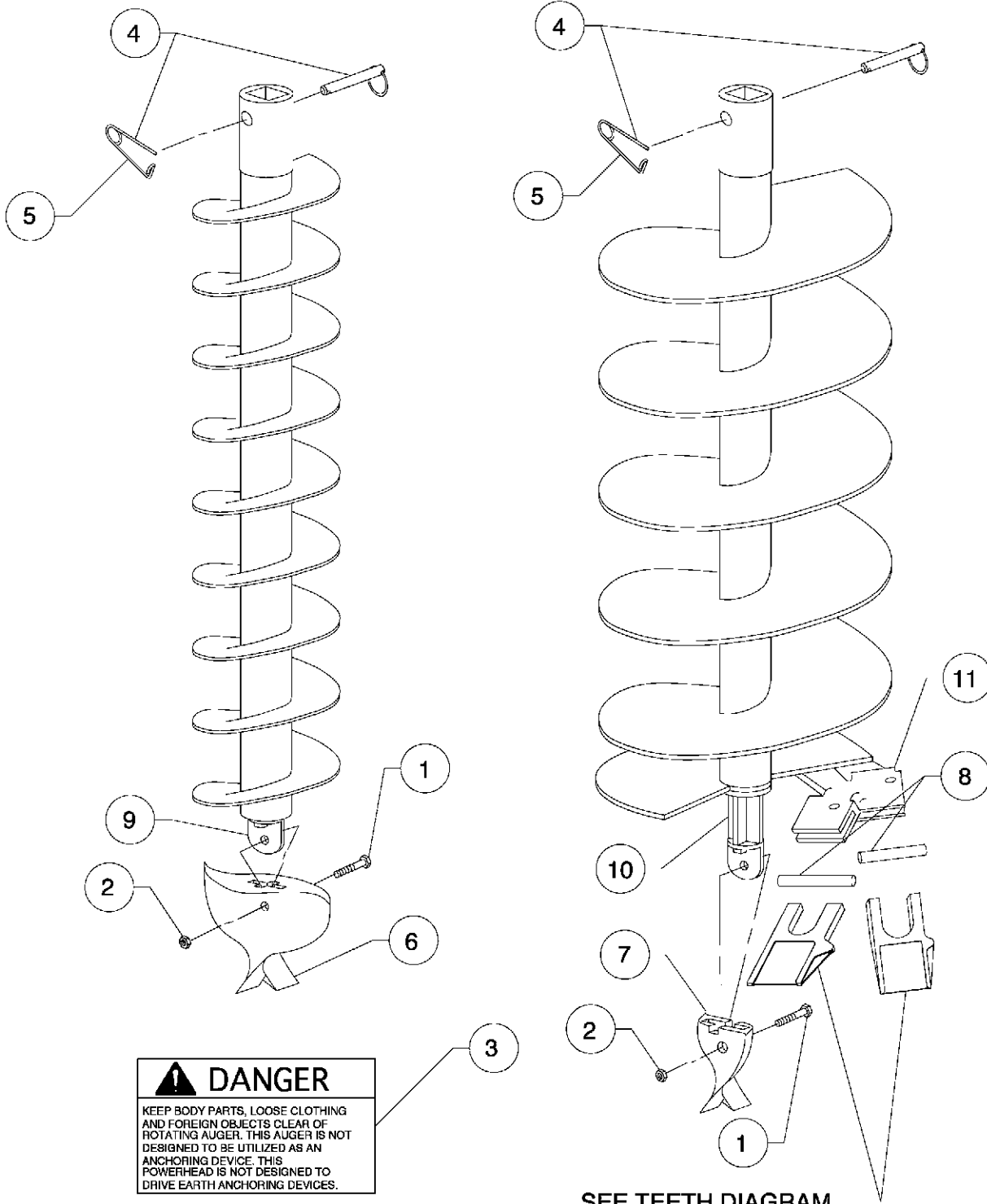

Replacement Parts Diagrams
PSD Series Earth Augers
7/8" Square (Ground Hog) Drive Connection
For Use With 342/343 Series Hole Diggers

Reference Number	PART NUMBER	DESCRIPTION	APPLICATION	QUANTIT Y
1	15051200	Screw, Cap, 5/16" x 1 1/2" UNC, Plated	All Augers	1
2	18050000	Nut, Hex, 5/16" UNC, Plated	All Augers	1
3	233-5092	Decal, Danger	All Augers	1
4	2021	Pin, Auger (Includes P/N AP-21-S)	All Augers	1
			PSD-15X Extension	1
5	AP-21-S	Pin, Safety	All Augers	1
			PSD-15X Extension	1
6	SB45	Bit, Screw	PSD4 Auger	1
7	SB25	Bit, Screw	PSD6 thru PSD12	
			Augers	1
8	RL	Lock, Rubber	PSD6 thru PSD12	
			Augers	As Reg
9	141M	Lug, Drive (Weld On)	PSD4 Auger	1
10	140CS	Lug, Drive (Weld On)	PSD6 thru PSD12	
			Augers	1
11	6CS	Shank, 6" (Weld On)	PSD6 Auger	1
	8CS	Shank, 8" (Weld On)	PSD8 Auger	1
	12CS	Shank, 12" (Weld On)	PSD10 and PSD12 Augers	1

**Replacement Parts Diagrams
BT360 Series Earth Augers
Stihl Type Drive Connection
For Use With 356/357 Series Hole Diggers**

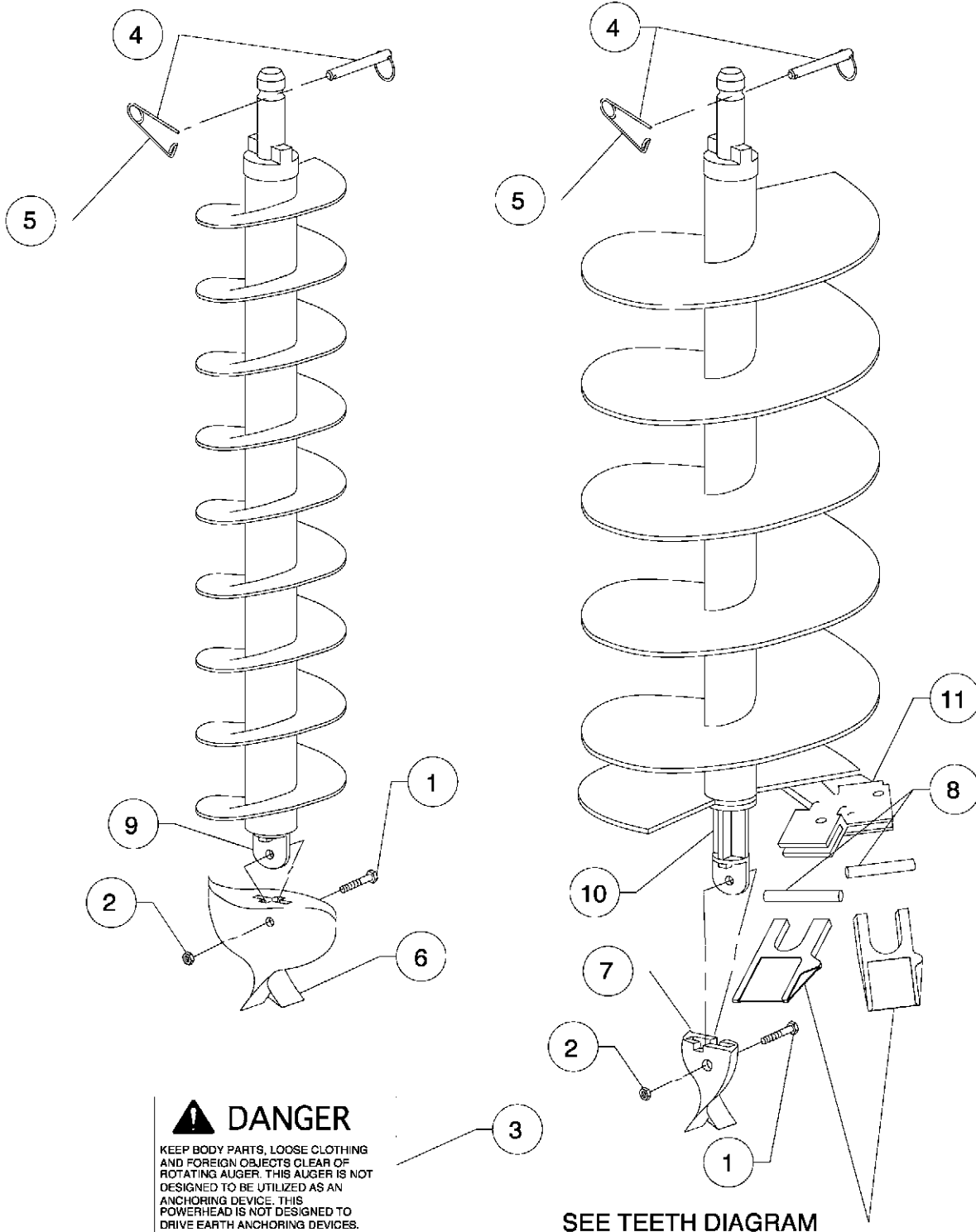

Replacement Parts Diagrams
BT360 Series Earth Augers
Stihl Type Drive Connection
For Use With 356/357 Series Hole Diggers

Reference Number	PART NUMBER	DESCRIPTION	APPLICATION	QTY
1	15051200	Screw, Cap, 5/16" x 1 1/2" UNC, Plated	All Augers	1
2	18050000	Nut, Hex, 5/16" UNC, Plated	All Augers	1
3	233-5092	Decal, Danger	All Augers	1
4	2121	Pin, Auger (Includes P/N AP-21-S)	All Augers	1
			BT360-15X Extension	1
5	AP-21-S	Pin, Safety	All Augers	1
			BT360-15X Extension	1
6	SB45	Bit, Screw	BT360-4E Auger	1
7	SB25	Bit, Screw	BT360-6E thru BT360-18P Augers	1
8	RL	Lok, Rubber	BT360-6E thru BT360-18P Augers	As Reg
9	141M	Lug, Drive (Weld On)	BT360-4E Auger	1
10	140CS	Lug, Drive (Weld On)	BT360-6E thru BT360-18P Augers	1
11	6CS	Shank, 6" (Weld On)	BT360-6E And BT360-18P Augers	1
	8CS	Shank, 8" (Weld On)	BT360-8E Auger	1
	12CS	Shank, 12" (Weld On)	BT360-10E and BT360-12E Augers	1
			BT360-18P Augers	2

Replacement Teeth Diagrams For Use With 4400, PSD, And BT360 Series Earth Augers

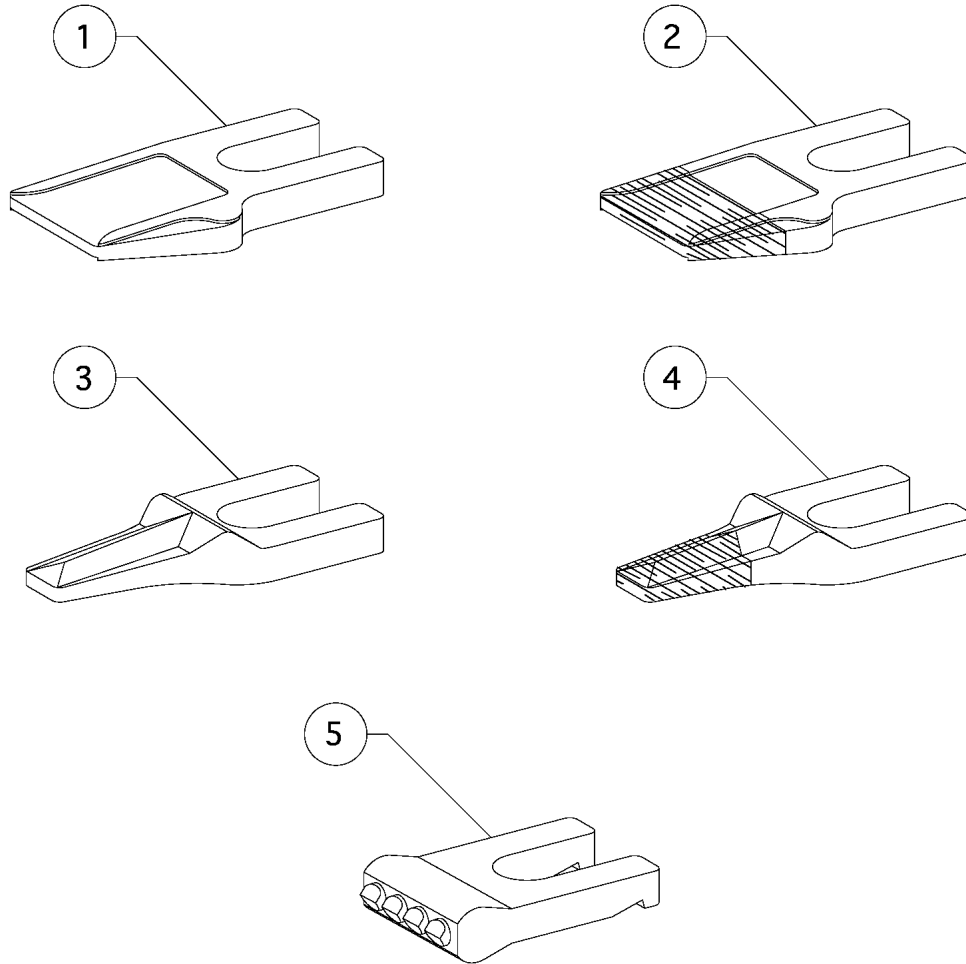

REFERENCE NUMBER	PART NUMBER	DESCRIPTION	QUANTITY
1	35	Dirt Tooth, Standard	As Required
2	35HFC	Dirt Tooth, Hard Faced	As Required
3	5T30	Tooth, Chisel	As Required
4	5T30C	Tooth, Chisel, Hard Faced	As Required
5	1336	Tooth, Tungsten Carbide	As Required

Consult The Service Section Of This Manual For Specific Application Informaion

Display Stand Assembly 300 Series Hole Diggers

This drawing represents display stands (including variations) for the 300 Series Hole Diggers

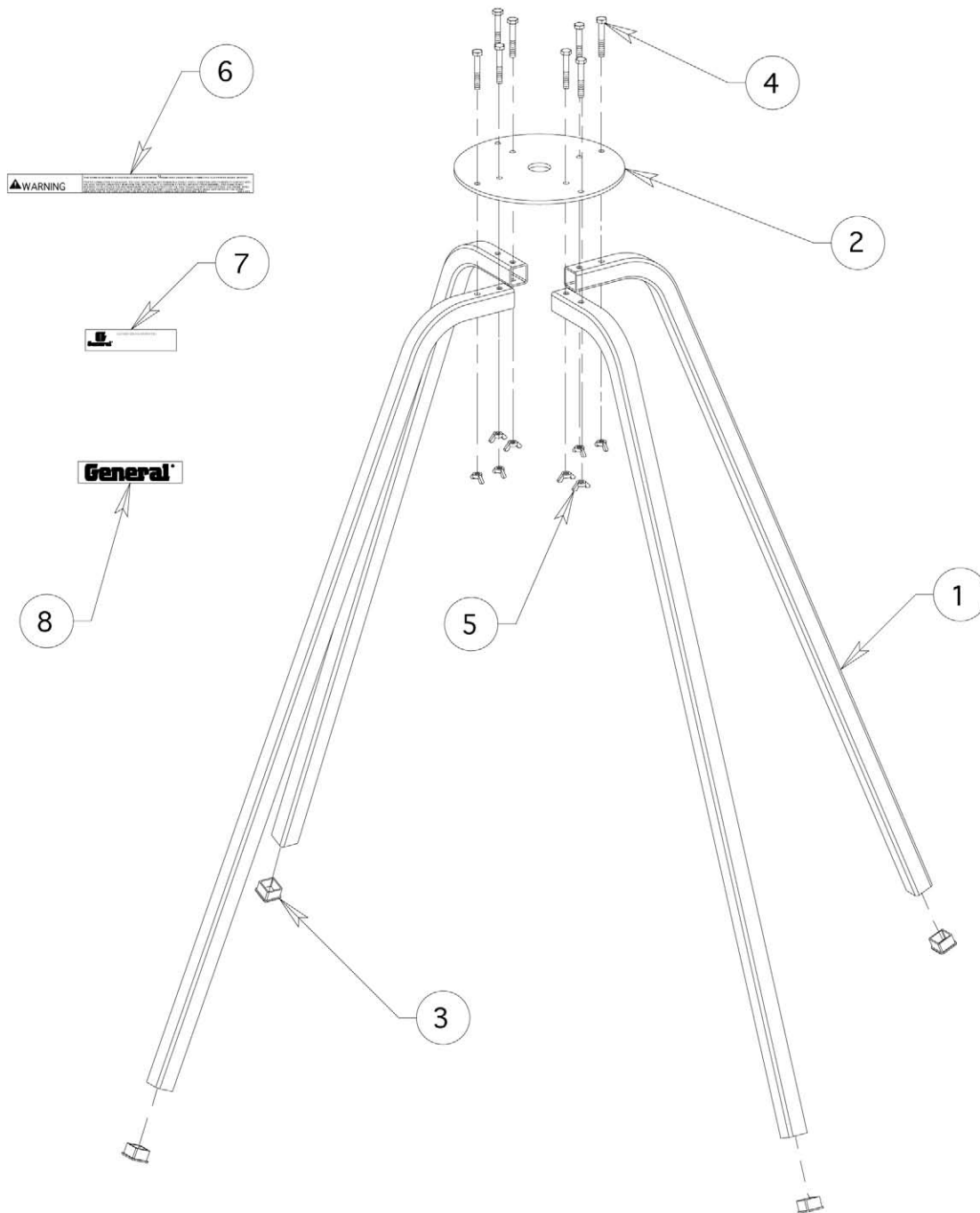

Display Stand Assembly 300 Series Hole Diggers

Reference Number	PART NUMBER	DESCRIPTION	QUANTITY
1	999-4-010	Leg, Stand (210 Hole Digger)	4
	999-5-010	Leg, Stand (300 Series Hole Diggers)	4
2	999-4-020	Plate, Top (210 Hole Digger)	1
	999-5-020	Plate, Top (310, 330, 342 & 343 Hole Diggers)	1
	999-12-020	Plate, Top (356 & 357 Hole Diggers)	1
3	FP-164	Cap, Plug, 1" Square	4
4	15041400	Screw, Cap, 1/4-20 UNC x 1-3/4", Plated	8
5	43040000	Nut, Wing, 1/4-20 UNC, Plated	8
6	999-4-5010	Decal, Warning	1
7	SG24-5070	Decal, Assistance	1
8	440-5010	Decal, General	1