

# OPERATION AND PARTS MANUAL



## **MODEL R2000H RIDE-ON STATIC ROLLER (Honda GX240K1QAE2 ENGINE)**

Revision #6 (11/29/10)

To find the latest revision of this  
publication, visit our website at:  
[www.multiquip.com](http://www.multiquip.com)



**THIS MANUAL MUST ACCOMPANY THE EQUIPMENT AT ALL TIMES.**



**CALIFORNIA — Proposition 65 Warning**

Engine exhaust and some of its constituents are known to the State of California to cause cancer, birth defects and other reproductive harm.



**Multiquip R2000H —  
Ride-On Static Roller**

Proposition 65 Warning ..... 2  
 Table Of Contents ..... 4  
 Parts Ordering Procedures ..... 5  
 Specifications (Roller) ..... 6  
 Specifications (Engine) ..... 7  
 Dimensions ..... 8  
 Safety Message Alert Symbols ..... 9-10  
 Rules For Safe Operation ..... 11-13  
 Operation and Safety Decals ..... 14  
 General Information ..... 15-16  
 Roller Components ..... 18-19  
 Engine Components ..... 20  
 Inspection ..... 21-22  
 Initial Start-Up ..... 23  
 Operation ..... 24-25  
 Maintenance ..... 26-28  
 Preparation For Long-Term Storage ..... 29  
 Troubleshooting (Roller) ..... 30  
 Troubleshooting (Engine) ..... 31  
 Explanation Of Code In Remarks Column ..... 32  
 Suggested Spare Parts ..... 33  
 Name Plate and Decals ..... 34-35  
 Brake Assembly ..... 36-37  
 Steering Assembly ..... 38-39  
 Chassis and covers Assembly ..... 40-41  
 Battery Assembly ..... 42-43  
 Rear Drum Assembly ..... 44-45  
 Drive Assembly ..... 46-47  
 Transmission Assembly ..... 48-49  
 Water System Assembly ..... 50-51

**Honda GX240K1QAE2 Engine**

Air Cleaner Assssembly ..... 52-53  
 Camshaft Assssembly ..... 54-55  
 Carburetor Assssembly ..... 56-57  
 Control Assssembly ..... 58-59  
 Crankcase Cover Assssembly ..... 60-61  
 Crankshaft Assssembly ..... 62-63  
 Cylinder Barrel Assssembly ..... 64-65  
 Cylinder Head Assssembly ..... 66-67  
 Fan Cover Assssembly ..... 68-69  
 Flywheel Assssembly ..... 70-71  
 Fuel Tank Assssembly ..... 72-73  
 Ignition Coil Assssembly ..... 74-75  
 Starter Motor Assssembly ..... 76-77  
 Control Box Assssembly ..... 78-79  
 Muffler Assssembly ..... 80-81  
 Piston Assssembly ..... 82-83  
 Recoil Starter Assssembly ..... 84-85  
 Engine Labels ..... 86-87  
 Terms and Conditions of Sale ..... 88

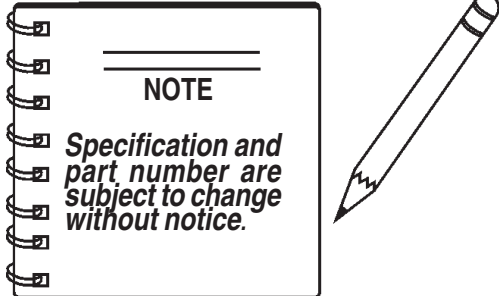

# PARTS ORDERING PROCEDURES

## Ordering parts has never been easier! Choose from three easy options:

Effective:  
January 1<sup>st</sup>, 2006

www.multiquip.com



### Order via Internet (Dealers Only):

Order parts on-line using Multiquip's SmartEquip website!

- View Parts Diagrams
- Order Parts
- Print Specification Information



If you have an MQ Account, to obtain a Username and Password, E-mail us at: [parts@multiquip.com](mailto:parts@multiquip.com).

To obtain an MQ Account, contact your District Sales Manager for more information.

Goto [www.multiquip.com](http://www.multiquip.com) and click on

**Order Parts** to log in and save!

Use the **internet** and qualify for a **5% Discount** on *Standard orders* for all orders which include complete part numbers.\*

Note: Discounts Are Subject To Change

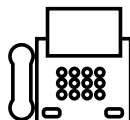

### Order via Fax (Dealers Only):

All customers are welcome to order parts via Fax.

**Domestic (US) Customers dial:**

1-800-6-PARTS-7 (800-672-7877)

**Fax** your order in and qualify for a **2% Discount** on *Standard orders* for all orders which include complete part numbers.\*

Note: Discounts Are Subject To Change



**Order via Phone: Domestic (US) Dealers Call:**  
1-800-427-1244

### Non-Dealer Customers:

Contact your local Multiquip Dealer for parts or call 800-427-1244 for help in locating a dealer near you.



**International Customers** should contact their local Multiquip Representatives for Parts Ordering information.

## When ordering parts, please supply:

- |   |  |
|---|--|
| <input type="checkbox"/> Dealer Account Number                                | <input type="checkbox"/> Specify Preferred Method of Shipment:                         |
| <input type="checkbox"/> Dealer Name and Address                              | <input checked="" type="checkbox"/> UPS/Fed Ex <input checked="" type="checkbox"/> DHL |
| <input type="checkbox"/> Shipping Address (if different than billing address) | <input type="checkbox"/> Priority One <input checked="" type="checkbox"/> Truck        |
| <input type="checkbox"/> Return Fax Number                                    | <input type="checkbox"/> Ground  |
| <input type="checkbox"/> Applicable Model Number                              | <input type="checkbox"/> Next Day  |
| <input type="checkbox"/> Quantity, Part Number and Description of Each Part   | <input type="checkbox"/> Second/Third Day  |

### NOTICE

All orders are treated as *Standard Orders* and will ship the same day if received prior to 3PM PST.

WE ACCEPT ALL MAJOR CREDIT CARDS!



## R2000H — SPECIFICATIONS (ROLLER)

**Table 1. R2000 Roller Specifications**

Dry Weight	1,382 lbs. (627 Kg.)
Full Ballast Weight	2,235 lbs. (1,014 Kg.)
Overall Length	73 in. (1,854 mm.)
Overall Width	37 in. (940 mm.)
Overall Height	51 in. (1,295 mm.)
Rolling Width	Front - 28 in. (711 mm.)
	Rear - 32 in. (813 mm.)
Roll Diameter	Front - 20 in. (508 mm.)
	Rear - 24 in. (610 mm.)
Ground Clearance	RH - 3.25 in. (83 mm.)
	LH - 9 in. (229 mm.)
Overhang	RH - 3.25 in. (83 mm.)
	LH - 1.75 in. (44 mm.)
Water Tank Capacity	21gallons 177 lbs. (79.5 liters 80.5 Kg.)
Front Rolls Capacity	15+15 gallons 250 lbs.(56.8+56.8 liters 114 Kg.)
Rear Roll Capacity	51 gallons 427 lbs. (193 liters 194 Kg.)
Travel Speed	5.6 mph (max. forward and reverse)
Maximum Gradient	27% (15 degrees)
Turning Radius (Inside)	10.5 ft. (3,200 mm.)
Steering	Mechanical (Chain)
Drive	V-belt driven hydrostatic transmission chain drive to rear roll
Parking Brake	Band-mechanical actuation
Electrical System	12V DC, neg. ground
Battery Type	Size Group 24 G2 40 Amp Hours
Battery Dimensions	9.25 x 7 x 7 in. (23.5 x17.8 x17.8 cm.)

## R2000H — SPECIFICATIONS (ENGINE)

**Table 2. Engine Specifications**

<b>Model</b>	<b>HONDA GX240K1QAE2</b>
Type	Air-cooled 4 stroke, Single Cylinder, OHV, Horizontal Shaft Gasoline Engine
Bore X Stroke	2.9 in. x 2.3 in. (73 mm x 58 mm)
Displacement	14.81 cu-in. (242cc)
Max Output	7.1 H.P./3600 R.P.M.
Fuel Tank Capacity	1.59 U.S. gal. (6 liters)
Fuel	Unleaded Automobile Gasoline
Lube Oil Capacity	1.16 U.S. qt. (1.1 liters)
Speed Control Method	Centrifugal Fly-weight Type
Starting Method	Electric Start
Dimension (L x W x H)	14.0 x 16.9 x 16.1 in. (355 x 430 x 410 mm)
Dry Net Weight	55.1 lbs. (25 Kg)

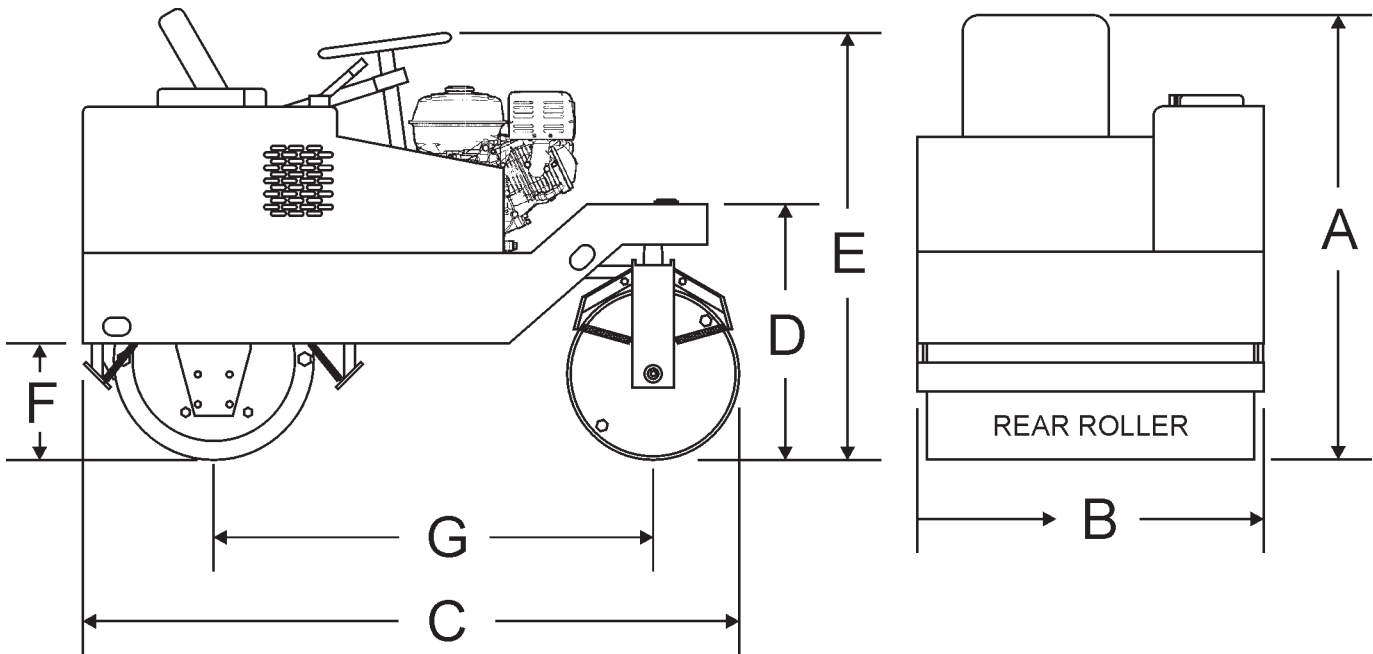

Figure 1. R2000H Roller Dimensions

TABLE 3. DIMENSIONS		
REF. LETTER	DESCRIPTION	DIMENSION IN. (MM.)
A	Overall Height	51 in. (1295 mm.)
B	Overall Width	37 in. (940 mm.)
C	Overall Length	73 in. (1854 mm.)
D	Front Frame Height	32 in. (813 mm.)
E	Steering Wheel Height	48 in. (1219 mm.)
F	Lower Frame Height	17 in. (432 mm.)
G	Wheel Base Length	50 in. (1270 mm.)



# R2000H — SAFETY MESSAGE ALERT SYMBOLS

## FOR YOUR SAFETY AND THE SAFETY OF OTHERS!

Safety precautions should be followed at all times when operating this equipment. Failure to read and understand the Safety Messages and Operating Instructions could result in injury to yourself and others.

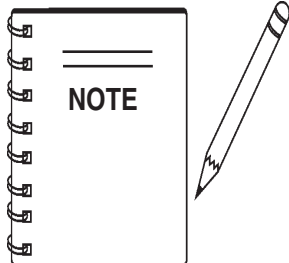

This Operation and Parts Manual has been developed to provide complete instructions for the safe and efficient operation of the **Multiquip Model R2000H** Static Roller. Refer to the engine manufacturer's instructions for data relative to its safe operation. **Before using this roller, ensure that the operating individual has read and understands all instructions in this manual.**

## SAFETY MESSAGE ALERT SYMBOLS

The three (3) Safety Messages shown below will inform you about potential hazards that could injure you or others. The Safety Messages specifically address the level of exposure to the operator, and are preceded by one of three words: **DANGER**, **WARNING**, or **CAUTION**.



**DANGER:** You **WILL** be **KILLED** or **SERIOUSLY** injured if you do not follow directions.



**WARNING:** You **CAN** be **KILLED** or **SERIOUSLY** injured if you do not follow directions.



**CAUTION:** You **CAN** be injured if you do not follow directions.

Potential hazards associated with MQ R2000H vibration roller operation will be referenced with Hazard Symbols which appear throughout this manual, and will be referenced in conjunction with Safety Message Alert Symbols.

## HAZARD SYMBOLS



### Lethal Exhaust Gases



Engine exhaust gases contain poisonous carbon monoxide. This gas is colorless and odorless, and can cause death if inhaled. **NEVER** operate this equipment in a confined area or enclosed structure that does not provide ample free flow air.



### Explosive Fuel



**GASOLINE** is extremely flammable, and its vapors can cause an explosion if ignited. **DO NOT** start the engine near spilled fuel or combustible fluids. **DO NOT** fill the fuel tank while the engine is running or hot. **DO NOT** overfill tank, since spilled fuel could ignite if it comes into contact with hot engine parts or sparks from the ignition system. Store fuel in approved containers, in well-ventilated areas and away from sparks and flames. **NEVER** use fuel as a cleaning agent.



### Burn Hazards



Engine components can generate extreme heat. To prevent burns, **DO NOT** touch these areas while the engine is running or immediately after operations. Never operate the engine with heat shields or heat guards removed.



### Rotating Parts



**NEVER** operate equipment with covers, or guards removed. Keep fingers, hands, hair and clothing away from all moving parts to prevent injury.

# R2000H — SAFETY MESSAGE ALERT SYMBOLS



## Accidental Starting



**ALWAYS** place the engine ON/OFF switch in the **OFF** position, and remove the ignition key when the machine is not in use.



## Respiratory Hazard



**ALWAYS** wear approved respiratory protection.



## Sight and Hearing hazard

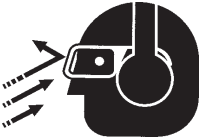

**ALWAYS** wear approved eye and hearing protection.



## Equipment Damage Messages

Other important messages are provided throughout this manual to help prevent damage to your roller, other property, or the surrounding environment.

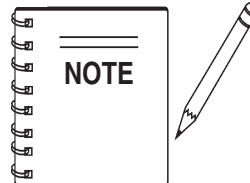

This roller, other property, or the surrounding environment could be damaged if you do not follow instructions.

# RULES FOR SAFE OPERATION

## DANGER:



Failure to follow instructions in this manual may lead to serious injury or even death! This equipment is to be operated by trained and qualified personnel only! This equipment is for industrial use only.

The following safety guidelines should always be used when operating the R2000H Roller:

### GENERAL SAFETY

- **DO NOT** operate or service this equipment before reading this entire manual.



- This equipment should not be operated by persons under 18 years of age.

- **NEVER** operate this equipment without proper protective clothing, shatterproof glasses, steel-toed boots and other protective devices required by the job.



- **NEVER** operate this equipment when not feeling well due to fatigue, illness or taking medicine.



- **NEVER** operate this equipment under the influence of drugs or alcohol.



- Whenever necessary, replace nameplate, operation and safety decals when they become difficult to read.

- **ALWAYS** check the machine for loosened threads or bolts before starting.

- **ALWAYS** wear proper respiratory (mask) hearing and eye protection equipment when operating the roller.



- **NEVER** touch the hot exhaust manifold, muffler or cylinder. Allow these parts to cool before servicing engine or pump.



- **High Temperatures** – Allow the engine to cool before adding fuel or performing service and maintenance functions. Contact with *hot* components can cause serious burns.

- The engine of this roller requires an adequate free flow of cooling air. Never operate the roller in any enclosed or narrow area where free flow of the air is restricted. If the air flow is restricted it will cause serious damage to the roller or engine and may cause injury to people and property. Remember the roller's engine gives off **DEADLY** gases.

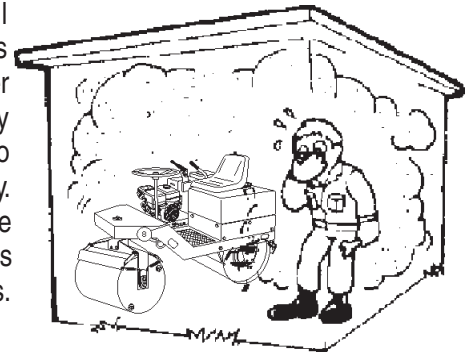

- **ALWAYS** refuel in a well-ventilated area, away from sparks and open flames.

- **ALWAYS** use extreme caution when working with **flammable** liquids. When refueling, **stop the** engine and allow it to cool. **DO NOT** smoke around or near the machine. Fire or explosion could result from fuel vapors, or if fuel is spilled on a hot engine.

- **NEVER** operate the roller in an explosive atmosphere or near combustible materials. An explosion or fire could result causing severe *bodily harm or even death*.

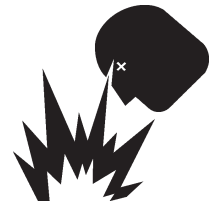

- Topping-off to filler port is dangerous, as it tends to spill fuel.

- Refer to the **Honda Engine Owner's Manual** for engine technical questions or information.

- **NEVER** use accessories or attachments, which are not recommended by Multiquip for this equipment. Damage to the equipment and/or injury to user may result.

- Manufacturer does not assume responsibility for any accident due to equipment modifications.

## RULES FOR SAFE OPERATION

- **NEVER** Run engine without air cleaner. Severe engine damage may occur.
- **ALWAYS** read, understand, and follow procedures in Operator's Manual before attempting to operate equipment.
- **ALWAYS** be sure the operator is familiar with proper safety precautions and operations techniques before using roller.
- **ALWAYS** store equipment properly when it is not being used. Equipment should be stored in a clean, dry location out of the reach of children.
- **DO NOT** operate this roller with hydrostatic oil temperature higher than 180 degrees fahrenheit.
- **NEVER** leave the roller unattended, turn off engine and place parking brake lever in upright position.
- **CAUTION** must always be observed while servicing this roller. Rotating parts can cause injury if contacted.
- **DO NOT** leave roller with engine running.
- If the roller must be stopped on an incline (grade), remove the ignition key and place chock blocks (not provided) under **the front** and **rear** drums.
- **NEVER** drive the roller on unshored trenches or near steep, unsupported banks. The vibration caused by the roller could cause a cave-in.
- **ALWAYS** use extreme care when operating near obstructions, on slippery surfaces, grades and side slopes.
- **ALWAYS** wear slip resistant safety shoes or boots.
- Unauthorized equipment modifications will void all warranties.
- When working on slopes, avoid **sidehill travel**. Operate up and down travel only. Remember, the danger of sliding on and/or tripping on steep slopes is always present.
- **ALWAYS** wear **seat belts**.
- When malfunctions occur, always remove the ignition key and place a "**DO NOT OPERATE**" sign in the operator's seat.
- If a malfunction occurs with the travel lever mechanism, speed and direction will be impossible to control. Immediately stop the roller and correct the problem.
- If the steering system operates improperly, immediately stop the engine and apply the parking brake.
- In the event of hydraulic hose or line failure, promptly return the travel lever to the "neutral" position, stop the engine and set the parking brake.
- Start the roller only when seated in the operator's position.
- Check all hydraulic components and fittings for wear.
- Before starting engine, ensure that there is smooth movement of the travel lever, throttle and parking brake.
- **ALWAYS** check **hydraulic oil, engine oil**, and fuel levels for leakage before starting engine.
- **High Temperatures** – Always stop engine and allow the engine to cool before adding fuel, oil or performing service and maintenance functions. Contact with *hot* components can cause serious burns.
- **NEVER** disconnect any "**emergency or safety devices**". These devices are intended for operator safety. Disconnection of these devices can cause severe injury, bodily harm or even death! Disconnection of any of these devices will void all warranties.

### Maintenance Safety

- **NEVER** lubricate components or attempt service on a running machine.
- **ALWAYS** allow the machine a proper amount of time to cool before servicing.
- Keep the machinery in proper running condition.
- Fix damage to the machine immediately and always replace broken parts, or missing decals.
- Dispose of hazardous waste properly. Examples of potentially hazardous waste are used motor oil, fuel and fuel filters.
- **DO NOT** use food or plastic containers to dispose of hazardous waste.
- **DO NOT** pour waste, oil or fuel directly onto the ground, down a drain or into any water source.

# RULES FOR SAFE OPERATION

## Loading and Transporting DANGER :



**DANGER! ALWAYS LOAD AND UNLOAD THE ROLLER ON LEVEL, HARD GROUND OR PAVEMENT.** Serious injury or death can result from improper loading, lifting or unloading. Use extreme caution!

- The roller has an operating weight of approximately 2,063 lbs. (938 Kg). Use lifting equipment capable of lifting this weight.
- **ALWAYS** check the roller's lifting hooks. Before lifting or transporting the roller, lock the frame with the locking bar that is provided. Make sure the hooks are secure and tight before lifting the machine.
- When driving the roller onto a transporting vehicle or trailer, use ramps or other suitable material of sufficient strength to support the roller.
- Remove mud, oil, ice, snow or any other slippery materials from the ramps and bed of the vehicle to avoid accidents.
- After loading, apply the parking brake.
- Use a chain, binders or other suitable means to firmly secure the roller before transporting.
- Only use the lifting points for the roller that are clearly marked as "**lifting point**".
- **NEVER** apply chains through the articulating section of the roller. The chain could cause damage by scoring the hydraulic steering cylinder.
- **NEVER** stand below roller when it is being lifted.

## DANGER :



**DO NOT** allow personnel to **stand under** or **near any suspended machine**. Serious injury or death may result.

## Emergencies

- **ALWAYS** know the location of the nearest **fire extinguisher**.



- **ALWAYS** know the location of the nearest and **first aid kit**.



- In emergencies **always** know the location of the nearest phone or **keep a phone on the job site**. Also know the phone numbers of the nearest **ambulance, doctor** and **fire department**. This information will be invaluable in the case of an emergency.

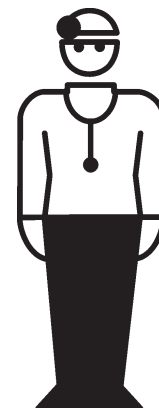
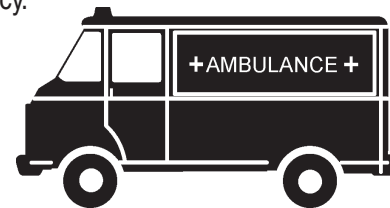

# OPERATION AND SAFETY DECALS

## Machine Safety Decals

The R2000H *static roller* is equipped with a number of safety decals. These decals are provided for operator safety and maintenance information. The illustration below and on the next page shows these decals as they appear on the machine. Should any of these decals become unreadable, replacements can be obtained from your dealer.



P/N: 34536



P/N: 513393

# MQ MULTIQUIP

P/N: 511740



P/N: 514418



P/N: 513668



P/N: 511738



P/N: 513698



P/N: 13118

# Econo-Roll

P/N: 514423

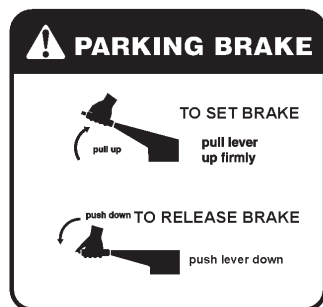

P/N: 514419



P/N: 514427

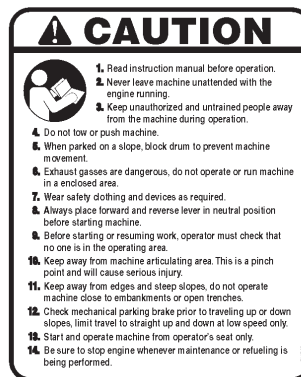

P/N: 511739



P/N: 491999

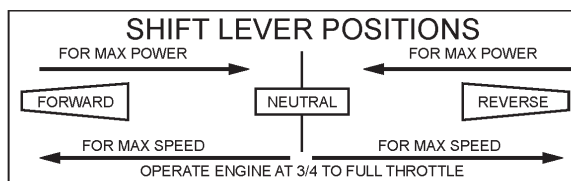

P/N: 513764



P/N: 514421



P/N: 514420

P/N: 514538

## R2000H — GENERAL INFORMATION

The R2000H roller has been designed for asphalt application and compaction of granular soils used in site preparation. Use the machine only for the purpose intended and by experienced personnel who understand this operating manual and all safety decals. Typical applications for this roller are driveways, patch work and road repairs.

### POWER PLANT

The R2000H roller is powered by a Honda GX240K1QAE2, air-cooled, gasoline engine rated at 7.1 hp @3,600 rpm. The engine features a side-mounted muffler designed to direct engine exhaust away from the operator. In the event of low oil, this engine has a built in "**oil alert system**" that will shut down if the engine oil level reaches an unsafe operating level.

### SPRINKLER SYSTEM

A 21 gallon (79.5 liters) water tank with a gravity feed spray bar is provided for wetting the roll for asphalt pavement rolling.

The water system is fully adjustable from the operator's position by adjusting the valve in the floor.

Water can be added to the front and rear rollers. Thirty gallons (250 lbs.) of water can be added to the front rollers, 51 gallons (427 lbs.) to the rear roller.

Before starting an asphalt rolling job, be sure all spray bar holes are clear of dirt or foreign matter and are working. Always use clean fresh water in the water tank. To prevent rust and foreign debris from clogging the spray bar holes, drain and flush water tank and spray bars every 30 days.

### LIFTING THE ROLLER

When lifting of the roller is required, attach a suitable hook or shackle to the **lifting eye** of the roller. These lifting points (4) are marked by a lifting hook decal. Make sure the lifting device is capable of lifting 4,000 lbs. (1,814 Kg.).



### ANGER:



Before operating the roller, make sure that personnel and obstacles are free from the roller's path. Serious injury or even death can result!

The forward-reverse control lever operates the hydrostatic pump which governs the roller speed and direction of travel. The speed in which movement of this lever is made is directly related to the amount of pressure that is applied to the travel lever in each direction. Travel speed is infinitely variable from 0 to 4 mph. The neutral position of this lever will cause the roller to stop.

### Danger

**NEVER!** stand under, or get onto the roller while it is being lifted or moved.

### CAUTION

**ONLY!** use approved certified lifting devices capable of lifting at least 4,000 lbs. (1,814 Kg.).

### CAUTION

When lifting of the roller is required, only use the provided **lifting eyes** to lift the roller. Using other sections of the roller for lifting purposes may cause severe damage to the roller.

### CAUTION

**DO NOT** operate this roller on **slippery** or **wet** surfaces.

### Danger

This roller is **not offered** with a **Rollover Protection Structure** (ROPS). The possibility exists of the roller tipping over causing severe bodily harm, even death, if side-side operation is used (Figure 3). **DO NOT** use this roller for side to side applications.

### OPERATING ON SLOPES

Special care must be taken when operating the roller on hills or slopes. There exist the possibility of serious injury to the operator and severe damage to the roller in the event of a roll over. **ALWAYS** operate the roller up and down hills rather than from side to side. For safe operation hillside slopes should not exceed 15 degrees (27 % grade). See Figure 2 below.

MAXIMUM SLOPE

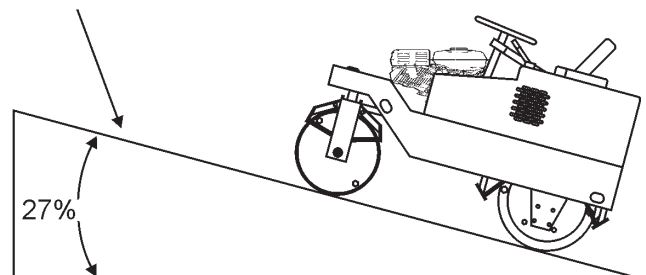

Figure 2. Recommended Slope

## Tipping (Rollovers)

**NEVER!** operate the roller on side slopes (Figure 3). The possibility exist that the roller could tip over (roll over), thus causing bodily harm even death and serious damage to the equipment.

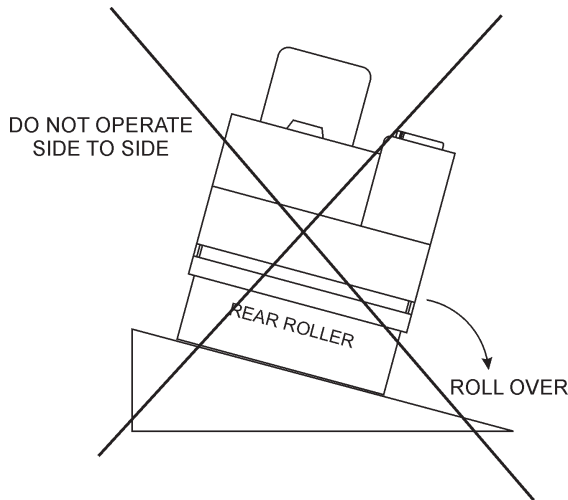

Figure 3. Tipping (Rollover)

In the event the roller does tip over, if at all possible, try to shut down the engine by turning the ignition key to the **OFF** position. Extreme care must be taken to prevent damage to the engine. When the roller has been tipped over, oil from the engine crankcase can flow into the combustion chamber, which can severely damage the engine the next time it is started.

**IMMEDIATELY** after a unit has tipped over upright the unit as soon as possible to prevent oil from leaking into the combustion chamber.

## CAUTION:



To prevent damage to the engine after a rollover, the roller must **NOT** be started. **NEVER** start a roller after a rollover. **CONTACT** your nearest authorized Multiquip dealer for instructions or servicing.

## WARNING:

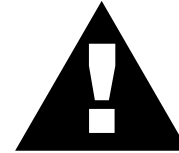

This roller is intended to be used on flat surfaces only. **DO NOT** use this roller near open trenches, hollow spaces or rocks that be below surface.

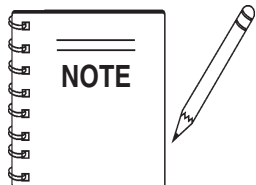

**NEVER!** operate the roller on **side slopes**. The roller may tip over causing injury to personnel and severe damage to the equipment.

## DANGER:



This roller is **not offered** with a **Rollover Protection Structure (ROPS)**. The possibility exists of the roller tipping over causing severe bodily harm, even death, if side-side operation is used (Figure 3). **DO NOT** use this roller for side to side applications.





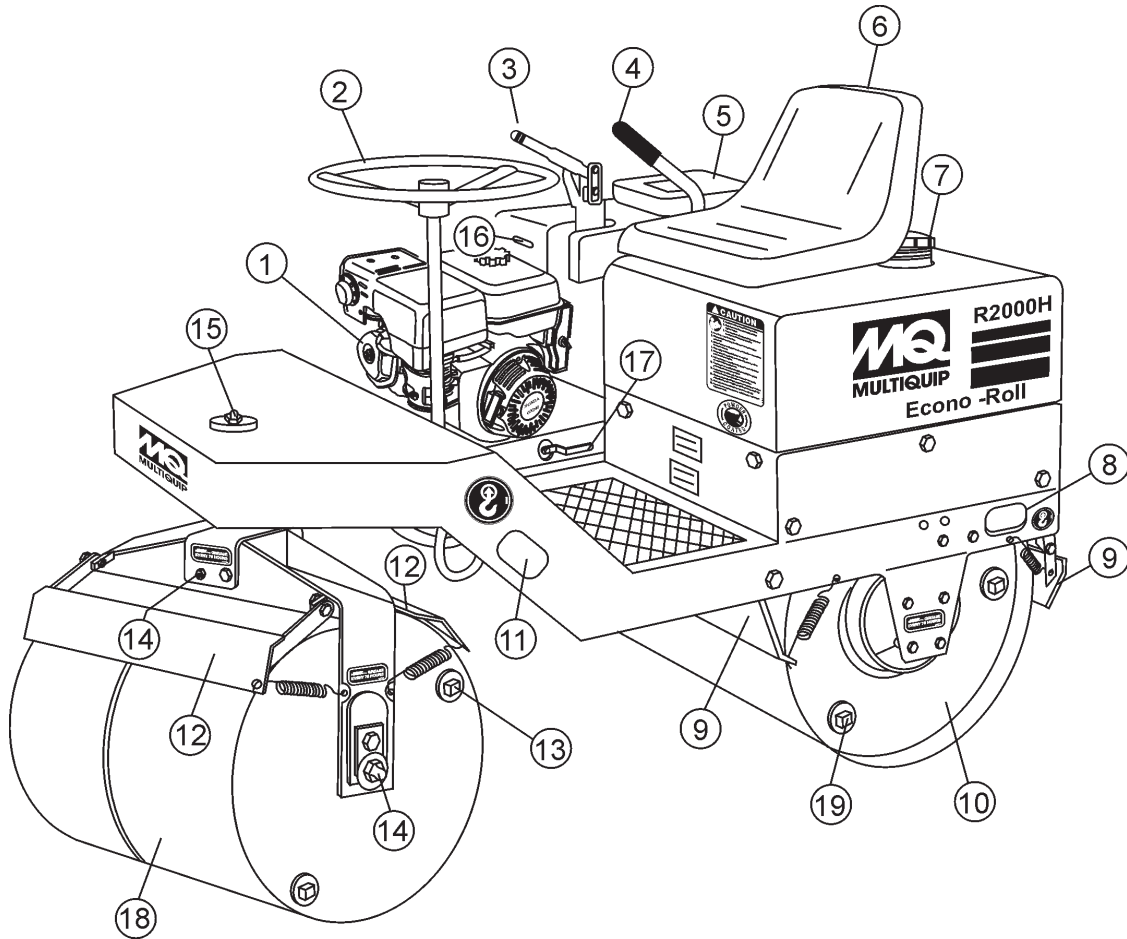

Figure 4. Roller Components

## R2000H — ROLLER COMPONENTS

1. **Engine** – The MQ R2000H ride-on roller uses an 7.1 HP Honda GX240K1QAE2 air cooled, 4-stroke, single cylinder gasoline engine. This engine uses unleaded gasoline.
2. **Steering Wheel** — Use this wheel to steer the roller.
3. **Parking Break Lever** — Pull the lever upward to set the parking break. To release the parking break, press and hold the button on top of the lever and push lever downward.
4. **Transmission Control Lever** — Push the lever **forward** to make the roller travel in a forward direction, pull the lever **backward** to make the roller travel in a reverse direction. Maximum travel speed is 5.6 MPH (9.0 KPH). Center position is neutral, no travel.
5. **Documentation Box** — Maintain and store **at all times** Operation, Parts, and Engine manuals in this box.
6. **Operator's Seat** — A contoured seat that provides visibility of both front rear drum edges during operation. **NEVER!** start the roller unless seated in the operator's seat.
7. **Water Tank/Cap** — Remove filler cap and fill with clean fresh water. Water tank capacity is 21 gallons (79.5 liters). If water level is low, add water as necessary.
8. **Rear Lifting Point** – Attach a crane or suitable lifting device to this point when lifting of the roller is required.
9. **Rear Scrapper** – This adjustable rear scrapper blade helps prevent the buildup of material between the drum and frame.
10. **Rear Roller** – This roller is a 32-inch wide **steel drum** with beveled edges (no vibration). The beveled edges help prevent asphalt marring.
11. **Front Lifting Point** – Attach a crane or suitable lifting device to this point when lifting of the roller is required.
12. **Front Scrapper** – This adjustable rear scrapper blade helps prevent the buildup of material between the drum and frame.
13. **Front Roller Water Plug** – Remove this plug to add water (ballast) to the front drum. This plug is located on each side of the split front roller.
14. **Front Roller Zerk Fitting** – Grease this fitting as recommended in the maintenance section of this manual.
15. **Steering Zerk Fitting** – Grease this fitting as recommended in the maintenance section of this manual.
16. **Access Panel** – Lift this -panel to gain access to the transmission assembly and battery.
  - A. **Transmission** – This roller uses a hydrostatic pump which provides hydraulic pressure to the hydraulic drive system. Fill the pump reservoir with hydrostatic transmission fluid. Fill with Mobil 300, GM Dextron B or Ford MCZ-41A type transmission fluid.

**Free Wheel Engagement Pin**

The hydrostatic transmission is equipped with a free wheel engagement pin, which, when actuated, allows the oil to circulate freely within the roller, thereby permitting the roller to be moved without the engine running. This engagement pin is only to be used in the event the roller is disabled.

This pin is located on the side of the hydrostatic transmission underneath the access cover. It is actuated by pushing the pin inward and placing the locking clip over the pin to keep it in place.

  - B. **Battery** – Provides +12VDC to the electrical system. Replace only with recommended type battery, see specification Table 1.
17. **Sprinkler Valve Lever** – A gravity feed spray bar is provided on the front and rear of the roller for the wetting of the roll for asphalt pavement. **Pull** upward on the lever to **start** the flow of water to the gravity feed system. **Push** the lever **downward** to **stop** the flow of water.
18. **Front Roller** – This roller is a **split** 28-inch wide **steel drum** with beveled edges (no vibration). The beveled edges help prevent asphalt marring.
19. **Rear Roller Water Plug** – Remove this plug to add water (ballast) to the rear drum. This plug is located on the chain-side of the roller. It is shown here for clarity only.

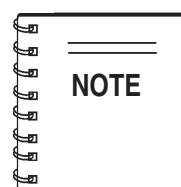

**Tie-Down Transport Points** – Attach a chain or suitable tie-down device to these points when transporting of the roller is required.

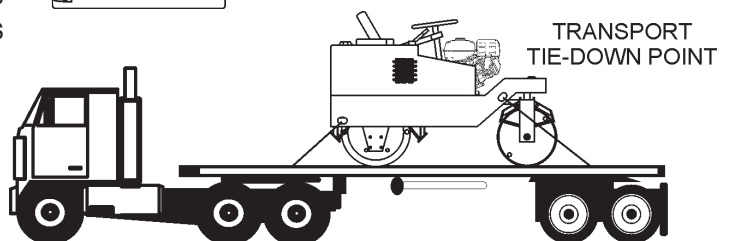

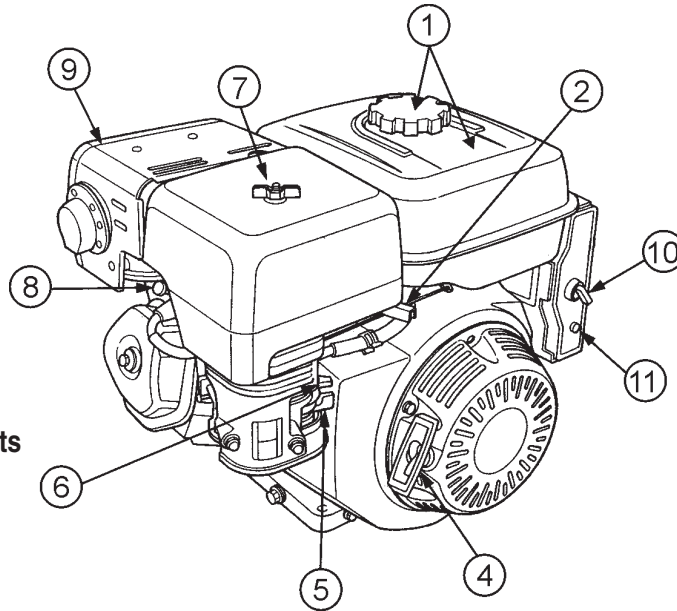

Figure 5. Engine Controls and Components

## INITIAL SERVICING (ENGINE)

The engine (Figure 5) must be checked for proper lubrication and filled with fuel prior to operation. Refer to the manufacturer's engine manual for instructions and details of operation and servicing.

1. **Fuel Filler Cap/Fuel tank** – Remove this cap to add unleaded gasoline to the fuel tank. Make sure cap is tightened securely. **DO NOT** over fill. Fuel tank capacity is 1.59 gallons (6.0 liters). Use unleaded gasoline. For additional information refer to Honda engine owner's manual.



### DANGER

Adding fuel to the tank should be done only when the engine is stopped and has had an opportunity to cool down. In the event of a fuel spill, **DO NOT**

attempt to start the engine until the fuel residue has been completely wiped up, and the area surrounding the engine is dry.

2. **Throttle Lever** – Used to adjust engine RPM speed (lever advanced forward **SLOW**, lever back toward operator **FAST**).
3. **Engine ON/OFF Switch** – ON position permits engine starting, OFF position stops engine operations.
4. **Recoil Starter (pull rope)** – Manual-starting method. Pull the starter grip until resistance is felt, then pull briskly and smoothly.
5. **Fuel Valve Lever** – **OPEN** to let fuel flow, **CLOSE** to stop the flow of fuel.

6. **Choke Lever** – Used in the starting of a cold engine, or in cold weather conditions. The choke enriches the fuel mixture.
7. **Air Cleaner** – Prevents dirt and other debris from entering the air intake system. Remove wing-nut on top of air filter canister to gain access to filter element.

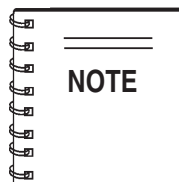

Operating the engine without an air filter, with a damaged air filter, or a filter in need of replacement will allow dirt to enter the engine, causing rapid engine wear.

8. **Spark Plug** – Provides spark to the ignition system. Set spark plug gap to 0.6 - 0.7 mm (0.028 - 0.031 inch) Clean spark plug once a week.
9. **Muffler** – Used to reduce noise and emissions.



### WARNING

Engine components can generate extreme heat. To prevent burns, **DO NOT** touch these areas while the engine is running or immediately after operating. **NEVER** operate the engine with the muffler removed.

10. **Ignition Switch**– Use this switch to start and stop the engine.
11. **Circuit Breaker**– Protects the battery charging circuit. See Honda owner's manual for additional information.

## CAUTION



**NEVER** operate the roller in a confined area or enclosed area structure that does not provide ample **free flow of air**.



**ALWAYS** wear approved eye and hearing protection before operating the roller.

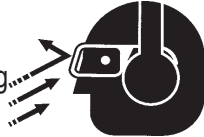

**NEVER** place hands or feet inside the guard rings while the engine is running. **ALWAYS** shut the engine down before performing any kind of maintenance service on the roller.



### Before Starting

1. Read safety instructions at the beginning of manual.
2. Clean the **roller**, removing dirt and dust, particularly the air filter and carburetor.
3. Check the air filter for dirt and dust. If air filter is dirty, replace air filter with a new one as required.
4. Check carburetor for external dirt and dust. Clean with dry compressed air.
5. Check fastening nuts and bolts for tightness.

### Engine Oil Check

1. To check the engine oil level, place the roller on secure level ground with the engine stopped.
2. Remove the filler dipstick from the engine oil filler hole (Figure 6) and wipe it clean.

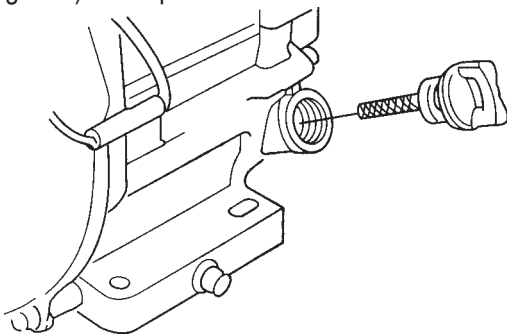
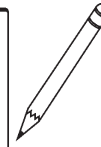
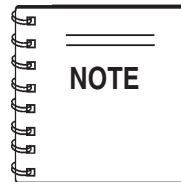

Figure 6. Engine Oil Dipstick (Removal)

3. Insert and remove the dipstick without screwing it into the filler neck. Check the oil level shown on the dipstick.
4. If the oil level is low (Figure 7), fill to the edge of the oil filler hole with the recommended oil type (Table 4). Maximum oil capacity is 400 cc.



Reference manufacturer engine manual for specific servicing instructions.

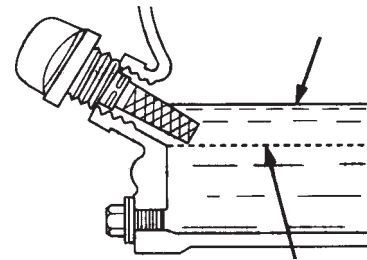

Figure 7 Engine Oil Dipstick (Oil Level)

Table 4. Oil Type

Season	Temperature	Oil Type
Summer	25°C or Higher	SAE 10W-30
Spring/Fall	25°C~10°C	SAE 10W-30/20
Winter	0°C or Lower	SAE 10W-10

## Explosive Fuel



## CAUTION



Motor fuels are highly flammable and can be dangerous if mishandled. **DO NOT** smoke while refueling. **DO NOT** attempt to refuel the roller if the engine is **hot!** or **running**.

### Fuel Check

1. Remove the gasoline cap located on top of fuel tank.
2. Visually inspect to see if fuel level is low. If fuel is low, replenish with unleaded fuel.
3. When refueling, be sure to use a strainer for filtration. **DO NOT** top-off fuel. Wipe up any spilled fuel.

## Water System Check

1. Check the water tank, located under the operator's seat, to see if filled (Figure 8). Add water if necessary. The water tank has a capacity of approximately 21 gallons (79.5 liters).

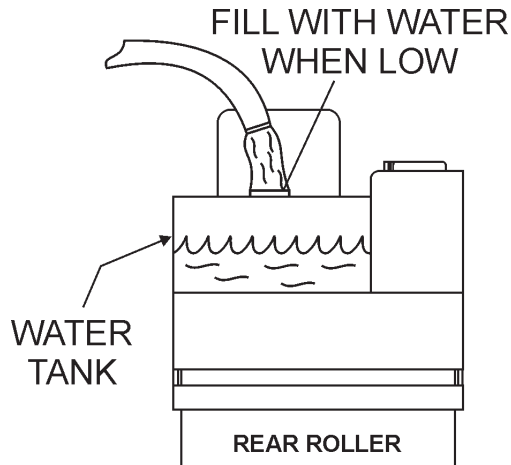

Figure 8. Water Tank Check

2. Water can also be added to the front and rear rollers. To fill, remove pipe plug from the roller side plate and position roller so that the hole is at the top. The right side cover must be removed to fill the rear roller. Replace plugs and side cover after filling. Thirty gallons (250 lbs.) of water can be added to the front rollers and 51 gallons (427 lbs.) of water can be added to the rear roller.
3. Protect water from freezing by adding antifreeze or draining water tank when not in use. Use only clean water in water tank.

## Battery Check

A 12-volt DC battery (Figure 9) is shipped dry, and will require a proper electrolyte level for operation.

**ALWAYS** be sure that the battery cables are properly connected to the battery terminals as shown below. Generally the **RED** cable will be connected to the positive terminal of the battery, and the **BLACK** cable will be connected to the negative terminal of the battery.

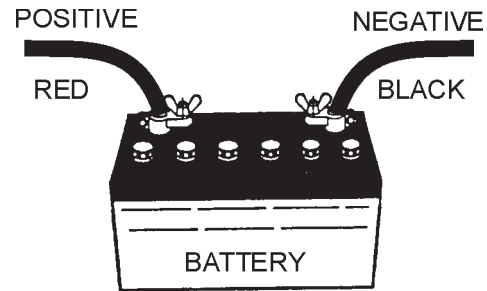

Figure 9. Battery

## WARNING



If the battery cables are connected incorrectly, electrical damage will occur causing damage to the roller's electrical circuits. Pay close attention to the polarity of the battery when connecting the battery.

## CAUTION:



**DO NOT** attempt to operate the roller until the Safety, General Information and Inspection sections have been read and understood.

1. Sit down in the operator's seat.
2. Before starting engine, make sure the immediate area is free of obstructions and debris that may lay in the roller's path.
3. Make sure that the roller's transmission control lever (Figure 10) is placed in the **neutral position**.

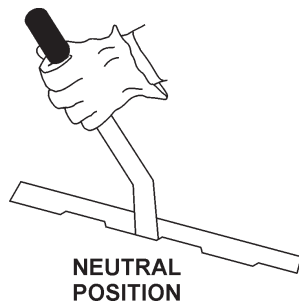
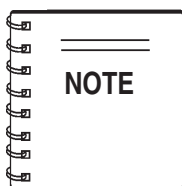

Figure 10. Transmission Control Lever



**NEVER** operate the roller with the access cover open. Keeping the cover closed will prevent dirt and debris from entering into the transmission and drivetrain assemblies. **ALWAYS keep the access cover closed for normal operation.**

## Starting the Engine

1. Place the engine **fuel valve lever** (Figure 11) to the "ON" position.

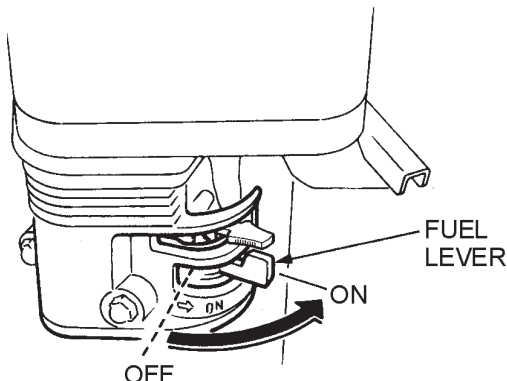

Figure 11. Engine Fuel Valve Lever

2. Rotate the **throttle lever** (Figure 12) halfway between **fast** and **slow** for starting. The engine governor speed is factory set to ensure optimum operating speeds.

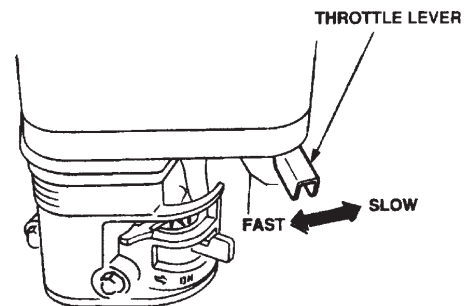
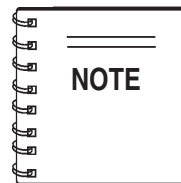

Figure 12. Throttle Lever



The **CLOSED** position of the choke lever enriches the fuel mixture for starting a **COLD** engine. The **OPEN** position provides the correct fuel mixture for normal operation after starting, and for restarting a warm engine.

3. Place the **Choke Lever** (Figure 13) in the "**CLOSED**" position.

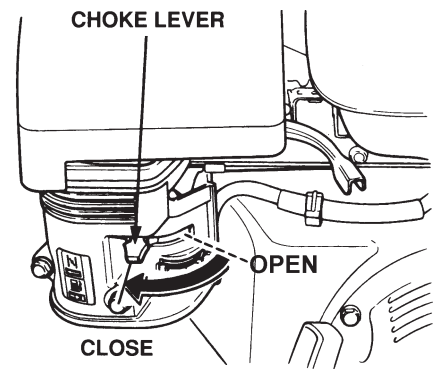
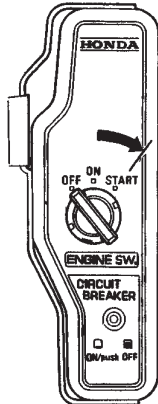

Figure 13. Choke Lever

4. Insert the ignition key into the ignition (Figure 14), place key in the **start** position, when engine starts release key.

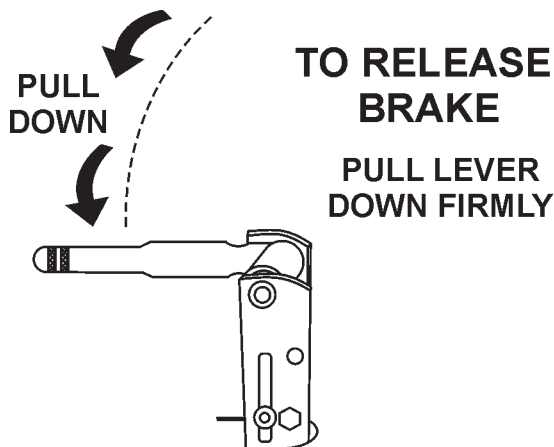

**Figure 14. Ignition Switch**

5. If the engine does not start, repeat steps 1 through 4 or consult the troubleshooting guide contained in this manual.
6. Let the engine warm for 3 to 5 minutes before using roller. Check for fuel and oil leaks, and noises that would associate with a loose guard and/or covers.
7. If necessary return the choke knob to the full **OPEN** position.

## OPERATION

1. Release the parking brake by pushing down on the parking brake lever.



2. To make the roller move in a **forward direction**, move the transmission control lever forward as shown in Figure 15. Make sure lever is securely place into notch.

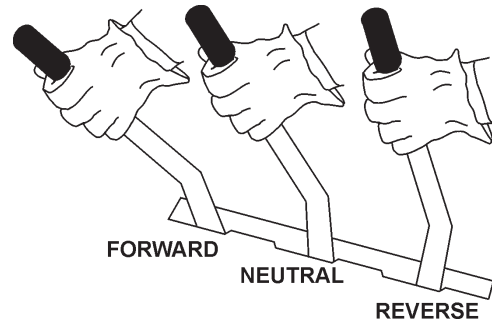

**Figure 15. Traveling Forward**

3. The speed of the roller is directly proportional to the amount of pressure being applied to the lever in each direction. Travel speed is between 0 and 4 mph (6.4 kph). The transmission control lever may be moved forward or reverse at any engine speed. However, it should not be moved rapidly as damage to the drive train may result.
4. Further adjustment of travel speed can be made by changing engine throttle setting. Maximum speed is attained with maximum engine speed and full forward or reverse lever position. Maximum power is attained with lever just out of neutral position and maximum engine speed

## WARNING



Transmission control lever must be in neutral position when starting engine. **NEVER** engage transmission abruptly because this places unnecessary high loads on all drive line components.

## WARNING



The **parking brake** must be used to hold the roller in the "**stopped**" condition. The transmission system will not hold the roller in a "stopped" condition.

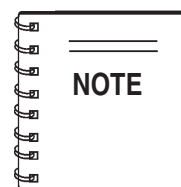

To **slow** or **stop** roller, move the transmission control lever toward the **neutral position**. If roller still cannot be slowed or stopped using the hydraulic braking system, use the **parking brake** to slow and then stop the roller.



## Water Sprinklers Control

1. If the application requires the wetting of a surface, open the **water valve** located at the bottom of the roller floor (Figure 16) to spread the proper amount of water onto the roller drum at the desired rate that will wet both the front and rear rollers.

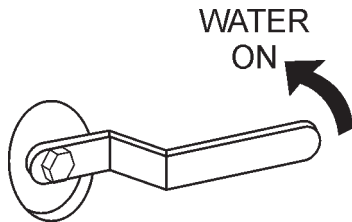

Figure 16. Water Sprinkler Valve (ON)

## Normal Shut-Down

1. Place the engine throttle lever in the idle position. Let the engine idle for 3-5 minutes.
2. If the water valve is open, close it (Figure 17)

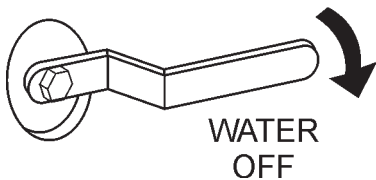

Figure 17. Water Sprinkler Valve (OFF)

3. **Place** the transmission lever (Figure 18) in the **neutral position**.

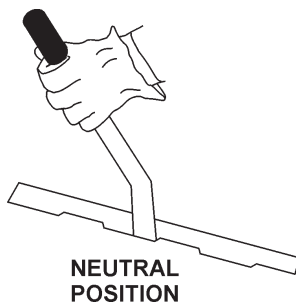

Figure 18. Transmission Control Lever (Neutral)

4. **Place** the parking brake lever (Figure 19) in the **set position**. This will lock the rear roller drum in place, and prevent the roller from moving. Whenever the operator's seat is vacated, place the transmission lever in neutral, and set the parking brake

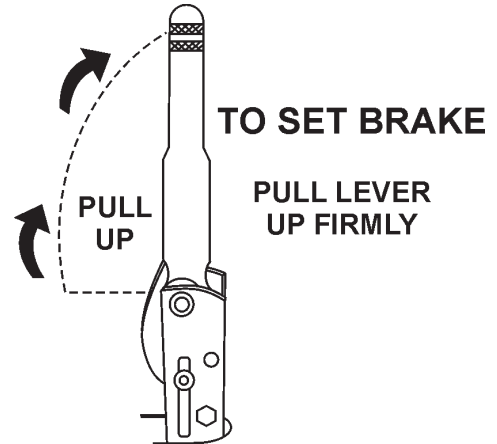

Figure 19. Parking Brake Lever (Set)

5. Turn the ignition key (Figure X) to the **OFF** position remove key. Store key in a safe place.

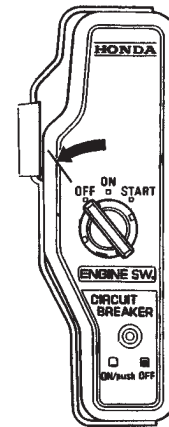

Figure 20. Ignition Switch (OFF)

6. Place the engine **fuel valve lever** (Figure 20) in the **OFF** position.
7. To prevent the roller from moving, place chock blocks under each roller drum
8. Clean the entire roller with warm water and mild soap. Pay close attention to the scrapper bar and spray bar holes, making sure that no dirt or debris is present. Dirt and debris can cause the sprinkler system to get clogged.

## Emergency Shut-Down

1. Turn the ignition key (Figure 20) to the **OFF** position.
2. Place the engine **fuel valve lever** (Figure 11) in the **OFF** position.

Read carefully and follow the maintenance instructions in this section. Always check the engine and transmission lubrication before using the roller.

## WARNING



Before servicing or performing maintenance, make sure that the engine is **off**, the parking brake is **on**, the transmission control lever is in the **neutral** position, and the spark plug is **disconnected** and secured away from the spark plug.

## Lubrication

Refer to the lubrication chart below for proper lubrication of roller. Follow the engine's manufacturer manual for engine lubrication.

**TABLE 5. R2000 LUBRICATION CHART**

ITEM	OIL TYPE	FREQUENCY
Hydrostatic Transmission	I.H. Hytran: Dextron B	Check daily before first start. Maintain at "cold" mark.
Front Axle	Mobil Grease MP or equivalent	Weekly
Front Roller Pivot Spindle	Mobil Grease MP or equivalent	Weekly
Front Roller Steering Spindle	Mobil Grease MP or equivalent	Weekly
Rear Roller Bearings	None needed. Bearings are lifetime lubricated	
Drive Chains	SAE 10W (keep clean)	Sparingly once a day

## Hydrostatic Transmission

1. Even minute amounts of foreign matter will cause major damage. If the reservoir screen is damaged, it must be replaced immediately.
2. The fluid will last under normal operating conditions, for the life of the transmission. If overheating or water contamination occurs, the oil will change from its normal reddish color to black or milky and must be replaced.
3. To drain the fluid, remove the plastic reservoir and the 3/8-16 hex head vent-plug from the top of the cast iron body.

## CAUTION



The threads connecting the reservoir to the aluminum body are left-handed. Turn transmission upside down to drain.

4. To refill, reassemble the hex head vent-plug and the plastic reservoir to the transmission. Refill through the reservoir with clean fluid. With the transmission control lever in full forward or reverse position, rotate the input pulley several times to flush the internal mechanism of the transmission and re-drain. Refill through the reservoir with an approved transmission fluid.
5. Prior to running the roller, the transmission fluid level should not be above the cold mark. Overfilling reduces the expansion are in the reservoir and fluid will spill out at operating temperatures.
6. Proper cooling is essential to both the performance and life of the transmission. Cooling is dependent on the fan and the fins on the body. Keep the fan tightened and replace it if the blades become broken. Keep the cooling fins clean.

## WARNING



Cleaning the transmission with high pressure water spray or live steam may force water into the reservoir. A few drops of water in the system will result in excessive oil expansion, loss of oil through the vent hole in the reservoir, and a loss of power at operating temperature. A shield or cover should be placed over the reservoir cover during cleaning operation or in other situations where water maybe introduced into the unit.

## Transmission Control Lever Adjustment

If the roller tends to creep when the control lever is in neutral, perform the following. Refer to Figure 21 for location of components.

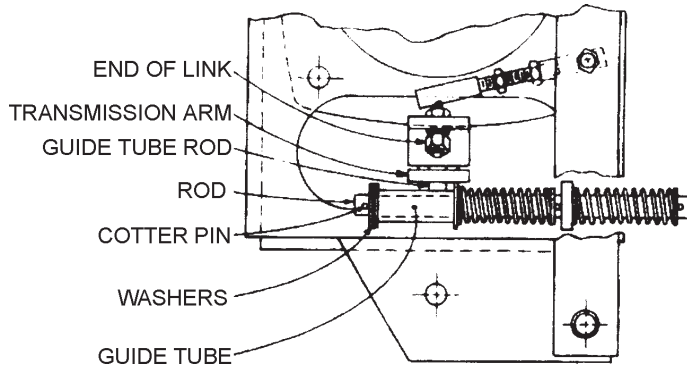

**Figure 21. Control Lever Adjustment Points**

1. Place the unit where there is ample clearance fore and aft.
2. Open the cover, place the control lever to neutral position, and remove cotter pin from rod.
3. Start engine and allow to run at idle speed.
4. Move control lever in reverse until roller just starts to move backwards.
5. Carefully hold the control lever in place and turn the engine off.
6. Without disturbing setting of control lever/transmission arm, add washers on rod between cotter pin hole and grid tube and replace cotter pin.
7. Return control lever to neutral position.
8. Check position of guide tube rod in arm slot. If not centered, remove end of link from arm, loosen lock nuts, adjust length by screwing ends in or out until ball stud drops in arm in centered position.
9. Tighten all nuts.
10. Restart engine and make sure transmission output sprocket does not move, at all engine speeds.

## Brake Adjustment

1. The brake should be adjusted so that it takes  $70 \pm 5$  lbs. of force applied at the end of the lever to fully actuate it.
2. To adjust brake, turn the knob located at the top of the brake lever clockwise (toward the operator) to tighten the brake.
3. Turn the knob counterclockwise (away from the operator) to loosen the brake.

## Steering Adjustment

1. The roller chain of the steering mechanism must be kept clean, lightly oiled and properly tensioned.
2. Adjust the turnbuckle to allow  $1/16$ " deflection to the slack side of the chain when in the straight position.

## Drive Chains

1. The drive chains must be kept clean, lightly-oiled, and properly tensioned.
2. When wear of the side bars, rollers or sprockets become noticeable, they should be replaced promptly.
3. Clean all dirt from the chain with solvent and re-oil lightly.

## Drive Chains Tension Adjustment

1. Move the roller slowly in the reverse direction until the slack side of the chain is toward the rear of the roller.
2. Put the control lever in the neutral position and shut the engine off and apply parking brake.
3. Loosen the two bolts that hold the idler plate forward (into the chain) using a pry bar.
4. Retighten the two mounting bolts.
5. Start the engine and move the roller in the forward direction, 5 to 10 feet.
6. Move the control lever to the neutral position and turn the engine off.
7. Proper chain tension is approximately 0.2 to 0.4-inch deflection with approximately 5 lbs. of force applied to the center of the span between the sprockets toward the front of the roller.
8. If the tension is still incorrect, readjust.

## Transmission V-Belt Adjustment

1. Keep pulleys clean and properly aligned using a straight edge. Correct belt tension is essential for the transmission to work properly and efficiently, and for the longevity of the belt.
2. Use a belt tension tester to check the belt tension.
3. Apply the load to the V-belt at the center of the span between the pulleys. The belt deflection should be approximately 1/4" with 3 1/2 lbs. to 4 lbs. load.

## CAUTION



**DO NOT** overtighten the V-belt. This will cause excessive strain on the transmission bearings, resulting in transmission failure.

## Scrapers, Cocoa Mats, and Sprinkler Bars

1. Keep roller scraper bars clean. Replace any broken or stretched spring. Prevent accumulation of tar or debris around pivot area.
2. Remove and replace the cocoa mats when badly worn by loosening the screws holding them in place. Remove the side panel first to replace the rear mats.
3. Fill the water tank through the large cap on the top rear. Use only clean water or the valve, hoses, and sprinkler bars may become clogged.

## Battery

The battery contains acids that can cause injury to the eyes and skin. To avoid eye irritation, **always** wear safety glasses. Use well insulated gloves when picking up the battery. Use the following guidelines when handling the battery:

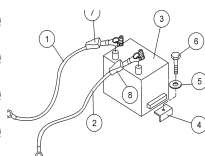

1. **DO NOT** drop the battery. There is the possibility of risk that the battery may explode.
2. **DO NOT** expose the battery to open flames, sparks, cigarettes etc. The battery contains combustible gases and liquids. If these gases and liquids come in contact with a flame or spark, an explosion could occur.

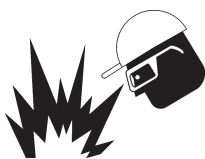

3. **ALWAYS** keep the battery charged. If the battery is not charged a buildup of combustible gas will occur.
4. **ALWAYS** keep battery charging and cables in good working condition. Repair or replace all worn cables.
5. **ALWAYS** recharge the battery in an vented air environment, to avoid risk of a dangerous concentration of combustible gases.
6. **ALWAYS** wear eye protection and rubber gloves, since the battery contains sulfuric acid which burns skin and eats through clothing.
7. **ALWAYS** recharge the battery in an vented air environment, to avoid risk of a dangerous concentration of combustible gases.
8. In case the battery liquid (dilute sulfuric acid) comes in contact with **clothing or skin**, rinse skin or clothing immediately with plenty of water.
9. In case the battery liquid (dilute sulfuric acid) comes in contact with your **eyes**, rinse eyes immediately with plenty of water, then contact the nearest doctor or hospital, and seek medical attention.

## CAUTION:



If your clothing or skin comes in contact with the battery acid, **immediately** wash off with running water and get medical attention.

- Check the battery regularly and make sure that each electrolyte level is to the bottom of the vent well (Figure 22). If necessary add only distilled water in a well-ventilated area.

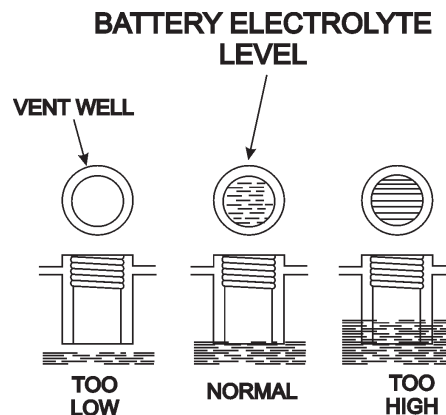

Figure 22. Battery Fluid Levels

### Roller Storage

For storage of the roller for over 30 days, the following is recommended:

- Drain the fuel tank completely, or add STA-BIL to the fuel.
- Run the engine until the fuel in the injection system is completely consumed.
- Completely drain used oil from the engine crankcase and fill with fresh clean oil, then follow the procedures described in the engine manual for engine storage.
- Drain water tank
- Clean the entire roller and engine compartment.
- Remove battery and store it in cool dry place.
- Cover the roller and place it a clean dry area, that is protected from harsh elements.
- Remove ignition key, and store in a safe place.

# R2000H — TROUBLESHOOTING (ROLLER)

**TABLE 6. ROLLER TROUBLESHOOTING**

SYMPTOM	POSSIBLE PROBLEM	SOLUTION
Roller Won't Go Forward or Reverse	Dump valve in?	Pull out dump valve.
	Low fluid (hydrostatic)?	Fill with fluid.
	Loose or broken belt?	Tighten belt or replace if necessary.
	Broken control linkage?	Repair control linkage
Low Power	Engine not running properly?	Refer to engine troubleshooting and manual.
	Slipping belt?	Tighten belt.
	Water in transmission (hydrostatic)?	Purge and replace.
	Transmission overheated (hydrostatic)?	Clean fins, replace broken fan, operate at lower speed setting.
Cannot Rotate Input Shaft	Damaged transmission?	See dealer.
Able to Rotate Output Shaft with Input Still	Low oil?	Fill oil.
	Damaged transmission?	See dealer.
Oil Leakage	Spillage?	Fill carefully.
	Expansion when warm?	Do not overfill when cold.
	Damaged reservoir?	Replace reservoir.
	Loose vent bolt, cover, gaskets?	Tighten.
	Bad control shaft seal?	Replace seal.
	Bad shaft seal?	See dealer.

# R2000H — TROUBLESHOOTING (ENGINE)

**TABLE 7. ENGINE TROUBLESHOOTING**

SYMPTOM	POSSIBLE PROBLEM	SOLUTION
<b>Difficult to start</b>		
Fuel is available but spark plug will not ignite. (Power available at high tension cable).	Ignition plug being bridge?	Check ignition system.
	Carbon deposit at ignition?	Clean or replace ignition.
	Short circuit due to defective insulators?	Replace insulators.
	Improper spark gap?	Set spark plug gap to the correct gap.
Fuel is available but spark plug will not ignite. (Power <b>NOT</b> available at high tension cable).	Short circuit at stop switch?	Check stop switch circuit. Replace stop switch if defective.
	Ignition coil defective?	Replace ignition coil.
Fuel is available and spark plug ignites (compression <b>normal</b> ).	Muffler clogged with carbon deposits?	Clean or replace muffler.
	Fuel in use inadequate (water, dust)?	Flush fuel sytem and replace with fresh fuel.
	Air Cleaner clogged?	Clean or replace air cleaner.
Fuel is available and spark plug ignites (compression <b>low</b> ).	Defective cylinder head gasket?	Tighten cylinder head bolts or replace head gasket.
	Cylinder worn?	Replace cylinder.
	Spark plug loose?	Tighen spark plug.
<b>Operation not satisfactory</b>		
Not enough power available (compression normal, no miss-firing).	Air cleaner clogged?	
	Air in fuel line?	Bleed (remove air) from fuel line.
	Fuel level in carbureator float chamber improper?	Adjust carbureator float
	Carbon deposits in cylinder?	Clean or replace cylinder
Not enough power available (compression normal, miss-firing).	Ignition coil defective?	Flush fuel sytem and replace with fresh fuel.
	Ignition plug often shorts?	Replace ignition wires, clean ignition.
	Fuel in use inadequate (water, dust)?	Flush fuel sytem and replace with fresh fuel.
Engine overheats.	Excessive carbon depostion in combustion chamber?	Clean or replace crankcase.
	Exhaust or muffler clogged with carbon.	Clean or replace muffler.
	Spark plug heat value incorrect?	Replace spark plug with correct type spark plug.
<b>Operation not satisfactory</b>		
Rotational speed fluctuates.	Governor adjustment improper?	Adjust governor to correct lever.
	Governor spring defective?	Clean or replace ignition.
	Fuel flow erratic?	Check fuel line.
	Air taken in through suction line?	Check suction line.
Recoil starter not working properly.	Dust in rotating part?	Clean recoil starter assembly.
	Spring spring failure?	Replace sprial spring.

# EXPLANATION OF CODE IN REMARKS COLUMN

The following section explains the different symbols and remarks used in the Parts section of this manual. Use the help numbers found on the back page of the manual if there are any questions.

## NOTICE

The contents and part numbers listed in the parts section are subject to change **without notice**. Multiquip does not guarantee the availability of the parts listed.

## SAMPLE PARTS LIST

NO.	PART NO.	PART NAME	QTY.	REMARKS
1	12345	BOLT.....	1	INCLUDES ITEMS W/%
2%		WASHER, 1/4 IN.....		NOT SOLD SEPARATELY
2%	12347	WASHER, 3/8 IN....	1	MQ-45T ONLY
3	12348	HOSE .....	A/R	MAKE LOCALLY
4	12349	BEARING .....	1	S/N 2345B AND ABOVE

## NO. Column

**Unique Symbols** — All items with same unique symbol

(@, #, +, %, or >) in the number column belong to the same assembly or kit, which is indicated by a note in the “Remarks” column.

**Duplicate Item Numbers** — Duplicate numbers indicate multiple part numbers, which are in effect for the same general item, such as different size saw blade guards in use or a part that has been updated on newer versions of the same machine.

## NOTICE

When ordering a part that has more than one item number listed, check the remarks column for help in determining the proper part to order.

## PART NO. Column

**Numbers Used** — Part numbers can be indicated by a number, a blank entry, or TBD.

TBD (To Be Determined) is generally used to show a part that has not been assigned a formal part number at the time of publication.

A blank entry generally indicates that the item is not sold separately or is not sold by Multiquip. Other entries will be clarified in the “Remarks” Column.

## QTY. Column

**Numbers Used** — Item quantity can be indicated by a number, a blank entry, or A/R.

A/R (As Required) is generally used for hoses or other parts that are sold in bulk and cut to length.

A blank entry generally indicates that the item is not sold separately. Other entries will be clarified in the “Remarks” Column.

## REMARKS Column

Some of the most common notes found in the “Remarks” Column are listed below. Other additional notes needed to describe the item can also be shown.

**Assembly/Kit** — All items on the parts list with the same unique symbol will be included when this item is purchased.

Indicated by:

“INCLUDES ITEMS W/(unique symbol)”

**Serial Number Break** — Used to list an effective serial number range where a particular part is used.

Indicated by:

“S/N XXXXX AND BELOW”

“S/N XXXX AND ABOVE”

“S/N XXXX TO S/N XXX”

**Specific Model Number Use** — Indicates that the part is used only with the specific model number or model number variant listed. It can also be used to show a part is NOT used on a specific model or model number variant.

Indicated by:

“XXXXX ONLY”

“NOT USED ON XXXX”

**“Make/Obtain Locally”** — Indicates that the part can be purchased at any hardware shop or made out of available items. Examples include battery cables, shims, and certain washers and nuts.

**“Not Sold Separately”** — Indicates that an item cannot be purchased as a separate item and is either part of an assembly/kit that can be purchased, or is not available for sale through Multiquip.



## MQ R2000H ROLLER WITH HONDA GX240K1QAE2 GASOLINE ENGINE

### *1 to 3 Units*

Qty.	P/N	Description
2	503837	V-BELT A43
1	530328	CHAIN, LARGE SPROCKET
1	530329	CHAIN, MASTER LINK
1	530334	CHAIN, SMALL SPROCKET
1	530336	CHAIN, MASTER LINK
1	530335	CHAIN LINK
1	509249	CAP, PLASTIC WATER TANK
1	530278	CHAIN, ROLLER
2	530279	CHAIN LINK, OFFSET 5/8"
3	530280	CHAIN LINK, STRAIGHT 5/8"
1	530340	EXTENSION, CHAIN
1	29299-401	CABLE, PARKING BRAKE
3	17210ZE2822	ELEMENT, AC DUAL
3	9807955846	SPARK PLUG
1	17620ZH7023	CAP, FUEL TANK
1	1762ZE2W01	FILTER, FUEL TANK
3	35111880003	KEY, IGNITION

# R2000H — NAME PLATE AND DECALS

## NAME PLATE AND DECALS

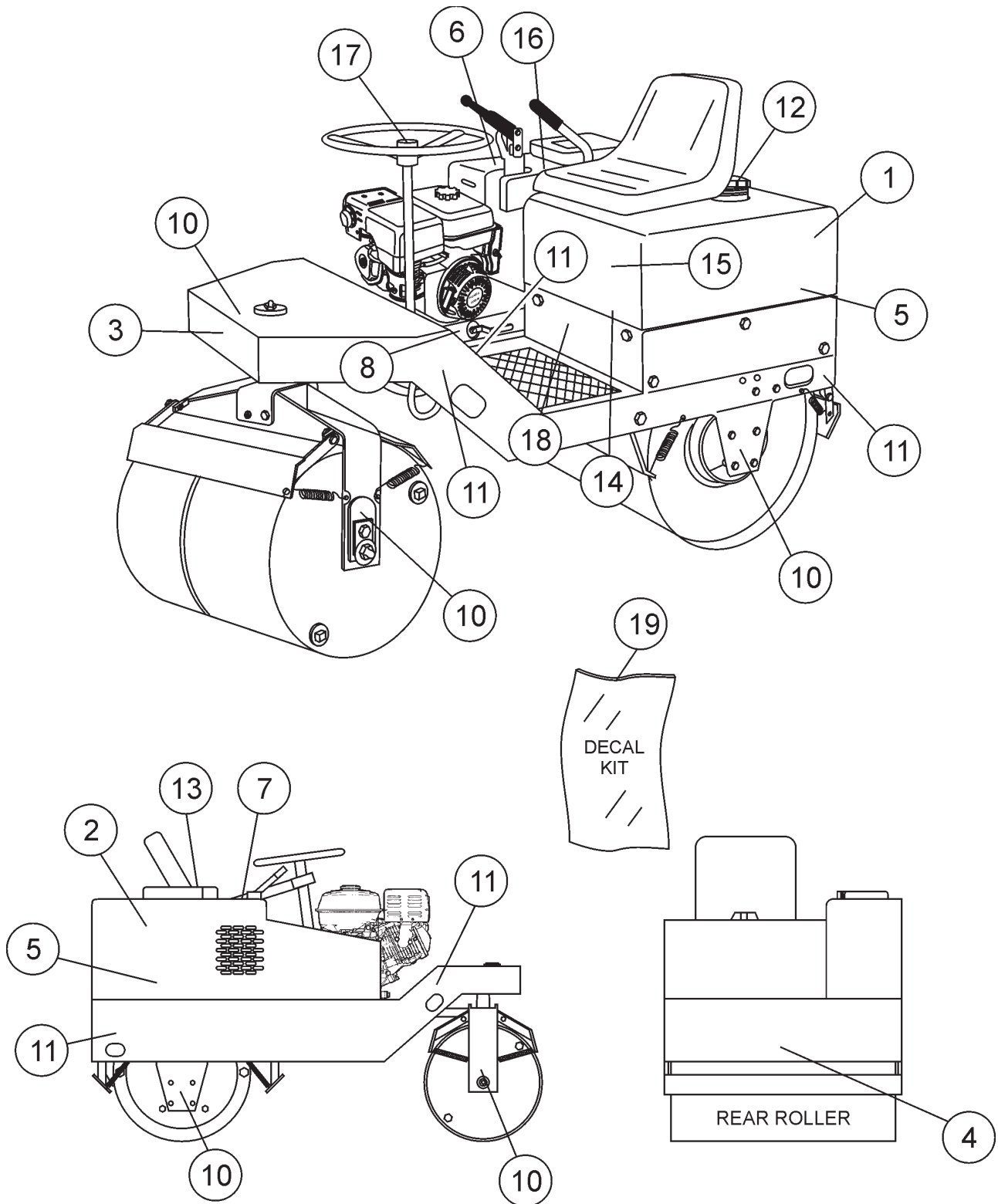

## R2000H — NAME PLATE AND DECALS

### NAME PLATE AND DECALS

<u>NO</u>	<u>PART NO</u>	<u>PART NAME</u>	<u>QTY.</u>	<u>REMARK</u>
1*	514538	DECAL, MQ R2000H LEFT	1	
2*	514420	DECAL, MQ R2000H RIGHT	1	
3*	513688	DECAL, MQ	1	
4*	511740	DECAL, MQ MULTIQUIP	1	
5*	514423	DECAL, ECONO-ROLL	2	
6*	514419	DECAL, PARKING BRAKE	1	
7*	514421	DECAL, COVER WARNING	1	
8*	514427	DECAL, SPRINKLERS	1	
9*	511738	DECAL, SLOPE WARNING	1	
10*	491999	DECAL, GREASE	5	
11*	513393	DECAL, LIFT POINT	4	
12*	513698	DECAL, WATER TANK CAP	1	
13*	34536	DECAL, OWNERS MANUAL	1	
14*	13118	DECAL, POWDER COATED	1	
15*	511739	DECAL, CAUTION OPERATION	1	
16*	513764	DECAL, SHIFT LEVER	1	
17*	514418	DECAL, MQ STEERING WHEEL	1	
18		PLATE, SERIAL NO. ....	1	..... CONTACT PARTS DEPT.
19	514424	KIT, R-2000 DECAL .....	1	..... INCLUDES ITEMS W/*

BRAKE ASSY.

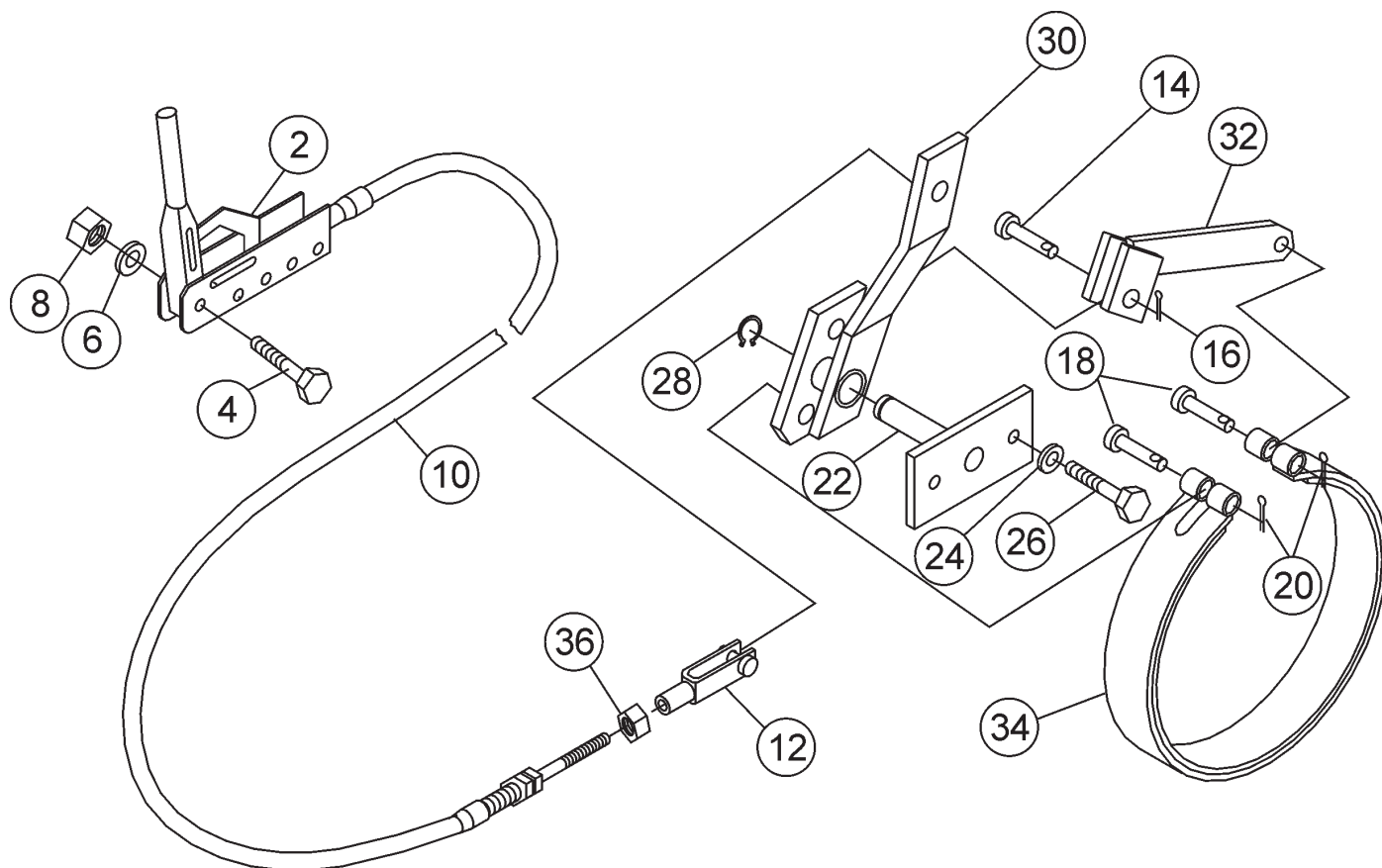

## BRAKE ASSY.

<u>NO</u>	<u>PART NO</u>	<u>PART NAME</u>	<u>QTY.</u>	<u>REMARK</u>
2	18057	LEVER, PARKING BRAKE	1	
4	492367	CAP SCREW 5/16"	3	
5	503736	SPACER	2	
6	EM923023	WASHER 5/16"	3	
8	2105164	HEX NUT 5/16" - 18	3	
10	29299-401	CABLE, PARKING BRAKE	1	
12	530342	ADJUSTABLE YOKE	1	
14	530343	CLEVIS PIN 3/8"	1	
16	509074	COTTER PIN 3/32"	1	
18	530344	CLEVIS PIN 1/2"	2	
20	2219	COTTER PIN 1/8"	2	
22	530345	SUPPORT, PIVOT LEVER	1	
24	6109180	WASHER 1/2"	2	
26	981635	CAP SCREW 1/2" - 13 NC x 1"	2	
28	EM490952	SNAP RING	1	
30	530346	LEVER, PIVOT	1	
32	530347	BRACKET, BRAKE	1	
34	29298-001	BRAKE BAND	1	
36	EM492566	JAM NUT 5/16" - 24 NF	1	

# R2000H — STEERING ASSY.

STEERING ASSY.

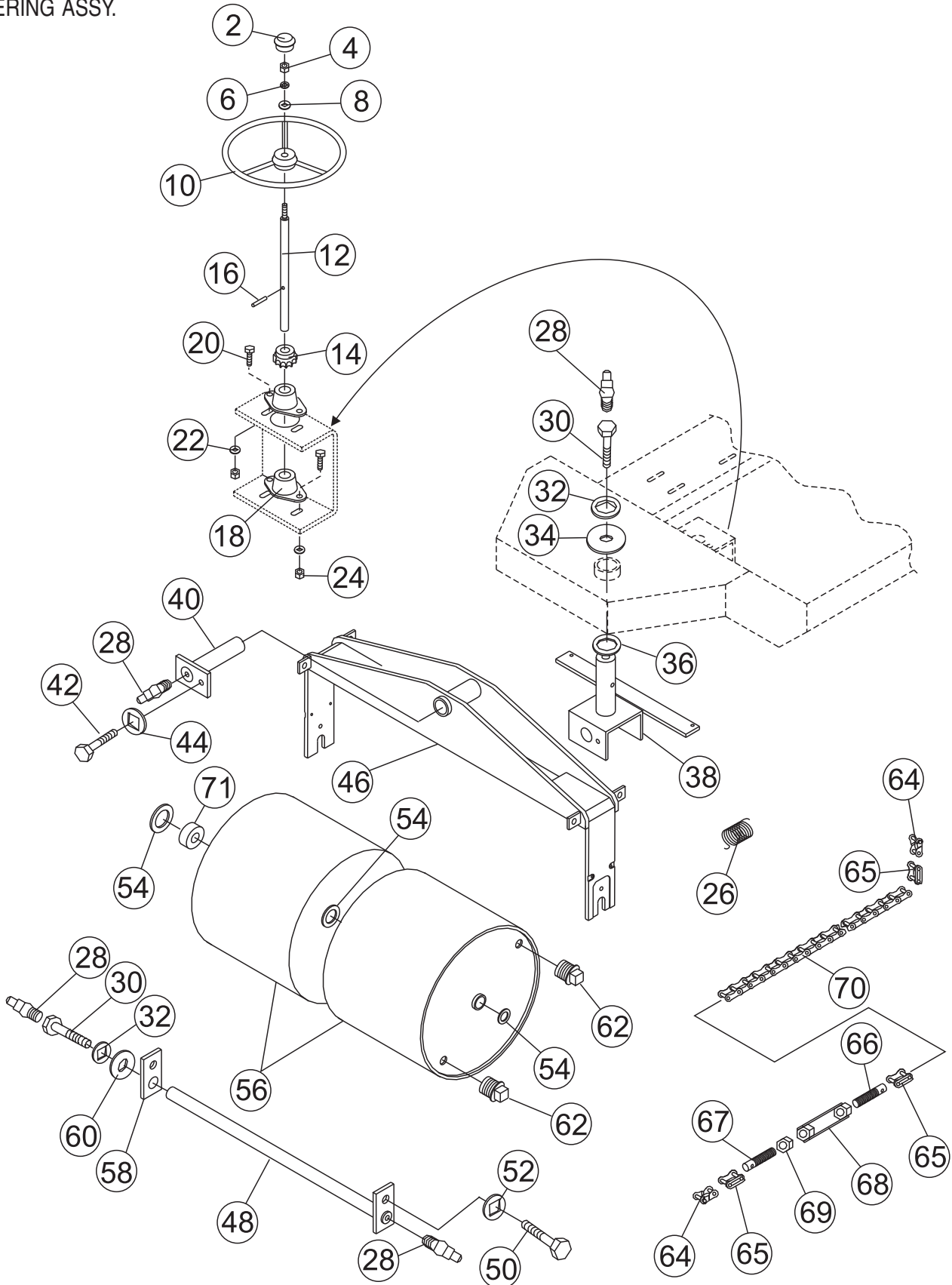

## STEERING ASSY.

<u>NO</u>	<u>PART NO</u>	<u>PART NAME</u>	<u>QTY.</u>	<u>REMARK</u>
2	19113-001	CAP	1	
4	492570	HEXNUT 5/8"	1	
6	EM923348	FLATWASHER 5/8"	2	
8	EM923023	WASHER 5/8"	1	
10	24182-001	STEERING WHEEL	1	
12	530273	STEERING POST	1	
14	24175-001	REAR ROLL	1	
16	530275	ROLL PIN	1	
18	24586-001	FLANGE BEARING	1	
20	0202	CAP SCREW 5/16" - 18 x 1"	4	
22	EM923023	WASHER 5/16"	4	
24	2105164	HEXNUT 5/16" - 18	4	
26	223871	SCRAPER SPRING	1	
28	EM916019	GREASE FITTING	3	
30	530283	CAP SCREW 5/8"	2	
32	EM923348	WASHER 5/8"	1	
34	530284	WASHER 5/8"	1	
36	530286	BRONZE WASHER	1	
38	530287	SPINDLE PIN	1	
40	530288	SPINDLE PIN	1	
42	EM963055	CAP SCREW 3/8", HEX HEAD	1	
44	0166 A	WASHER, LOCK 3/8"	1	
46	530289	FRONK YOKE	1	
48	530290	FRONT SHAFT	1	
50	981635	CAP SCREW 1/2" - 13 NC X 1"	2	
52	6109180	WASHER, LOCK 1/2"	2	
54	530291	BRONZE WASHER	3	
56	530292	FRONT ROLL UNIT	2	
58	530295	CLAMP BAR	1	
60	530015	WASHER 5/8"	1	
62	491214	PIPE PLUG	4	
64	530279	CHAIN LINK, OFFSET 5/8"	2	
65	530280	CHAIN LINK, STRAIGHT 5/8"	3	
66	530340	EXTENSION, CHAIN	1	
67	530281	EXTENSION, CHAIN	1	
68	530282	SPACER, CHAIN	1	
69	6109160	NUT, HEX 1/2"	1	
70	530278	CHAIN, ROLLER	1	
71	24600-001	BUSHING	4	

# R2000H — CHASSIS AND COVERS ASSY.

CHASSIS & COVERS ASSY.

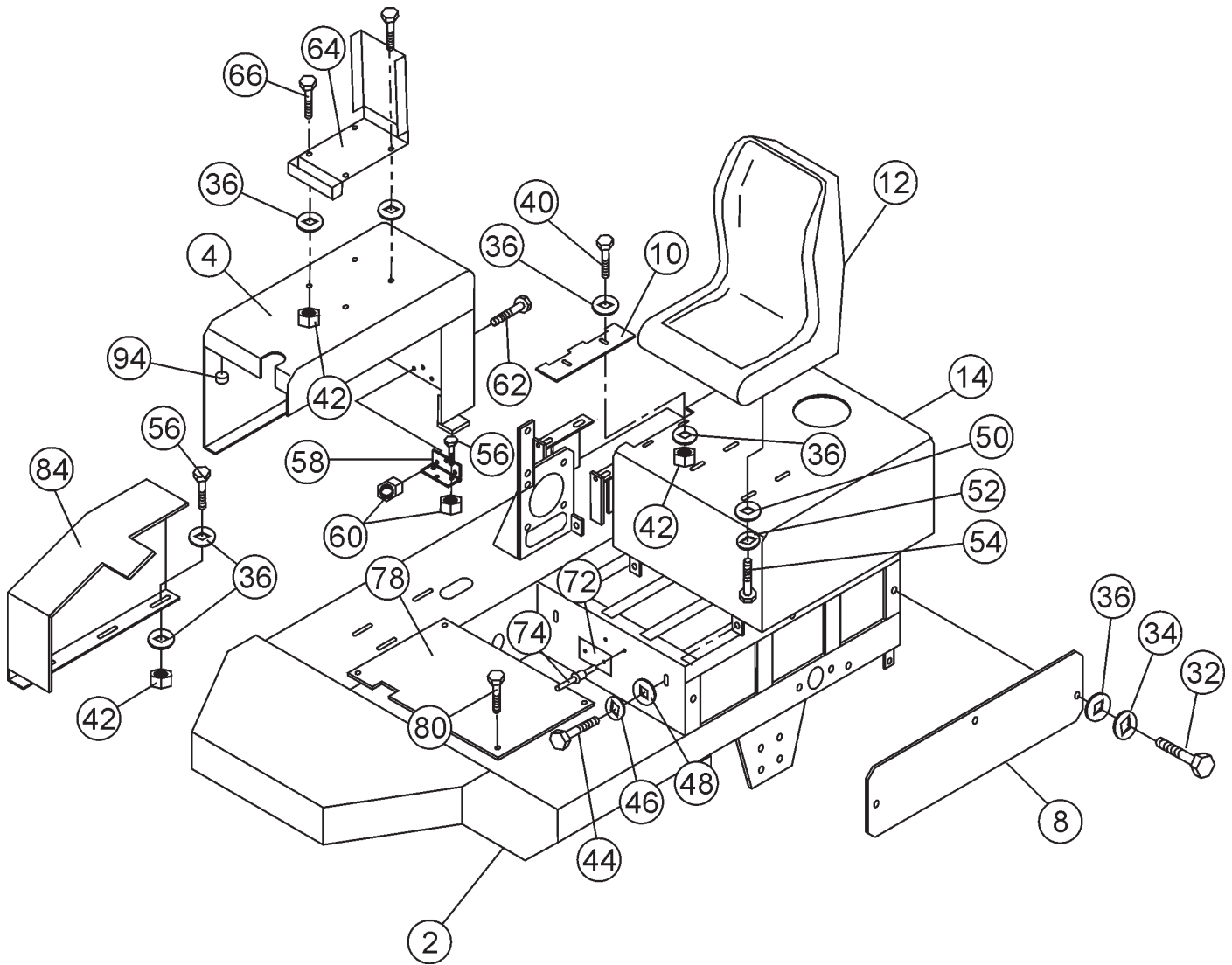



# R2000H — CHASSIS AND COVERS ASSY.

## CHASSIS & COVERS ASSY.

<u>NO</u>	<u>PART NO</u>	<u>PART NAME</u>	<u>QTY.</u>	<u>REMARK</u>
2	530364	MAIN BODY FRAME	1	
4	530365	GUARD, REAR	1	
8	530368	PANEL, LEFT SIDE	2	
10	530369	PLATE, SHIFTER	1	
12	19093-401	SEAT ASSY.	1	
14	530371	SEAT GUARD	1	
32	492356	CAP SCREW 1/4" x 3/4"	6	
34	2101402	WASHER, LOCK 1/4"	6	
36	492596	WASHER 1/4"	20	
40	492356	BOLT 1/4" x 3/4"	2	
42	2101428	NUT, HEX 1/4"	4	
44	EM963610	CAP SCREW 3/8" NC x 1-1/4"	4	
46	0166 A	WASHER, LOCK 3/8"	4	
48	508389	WASHER 3/8"	4	
50	510909	WASHER 3/8"	4	
52	0166 A	WASHER, LOCK 3/8"	4	
54	EM963610	CAP SCREW 3/8" NC 1-1/4"	4	
56	492357	CAP SCREW 1/4"	6	
58	503740	HINGE	2	
60	2101428	NUT, HEX 1/4"	12	
62	492355	HEX SCREW 1/4" - 20 x 1/2"	6	
64	29057	BOX, DOCUMENT	1	
66	492356	BOLT 1/4" x 3/4"	2	
68	492596	WASHER, FLAT 1/4"	4	
72	34516	PLATE, SERIAL NUMBER .....	1 .....	CONTACT PARTS DEPT. W/ MODEL & SERIAL NO.
74	491757	RIVET 1/8"	2	
78	530463	FLOOR PLATE, ALUMINUM	1	
80	506158	BOLT, 5/16" x 3/4"	4	
82	2105164	NUT, 5/16"	4	
84	530464	GUARD, FRONT	1	
94	505186	CUSION, RUBBER	2	

BATTERY ASSY.

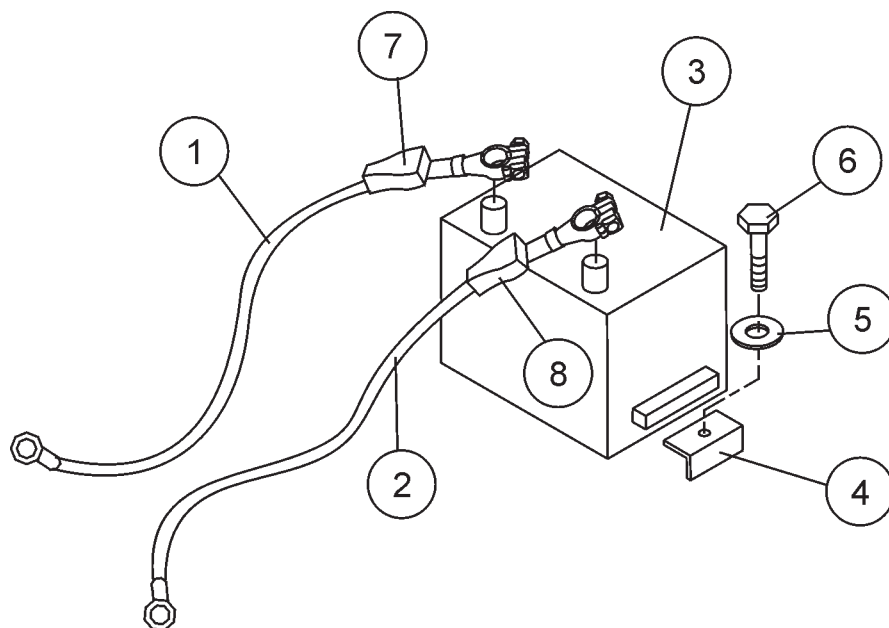

## BATTERY ASSY.

<b><u>NO</u></b>	<b><u>PART NO</u></b>	<b><u>PART NAME</u></b>	<b><u>QTY.</u></b>	<b><u>REMARK</u></b>
1	530372	BATTERY CABLE POSITIVE	1	
2	530373	BATTERY CABLE NEGATIVE	1	
3	507590	BATTERY 12V	1	
4	506151	CLAMP, BATTERY	2	
5	3019092	WASHER 3/8"	2	
6	492379	CAP SCREW 3/8"	2	
7	506266	BATTERY TERMINAL COVER.....	1 .....	RED
8	505624	BATTERY TERMINAL COVER.....	1 .....	BLACK

# R2000H — REAR DRUM ASSY.

REAR DRUM ASSY.

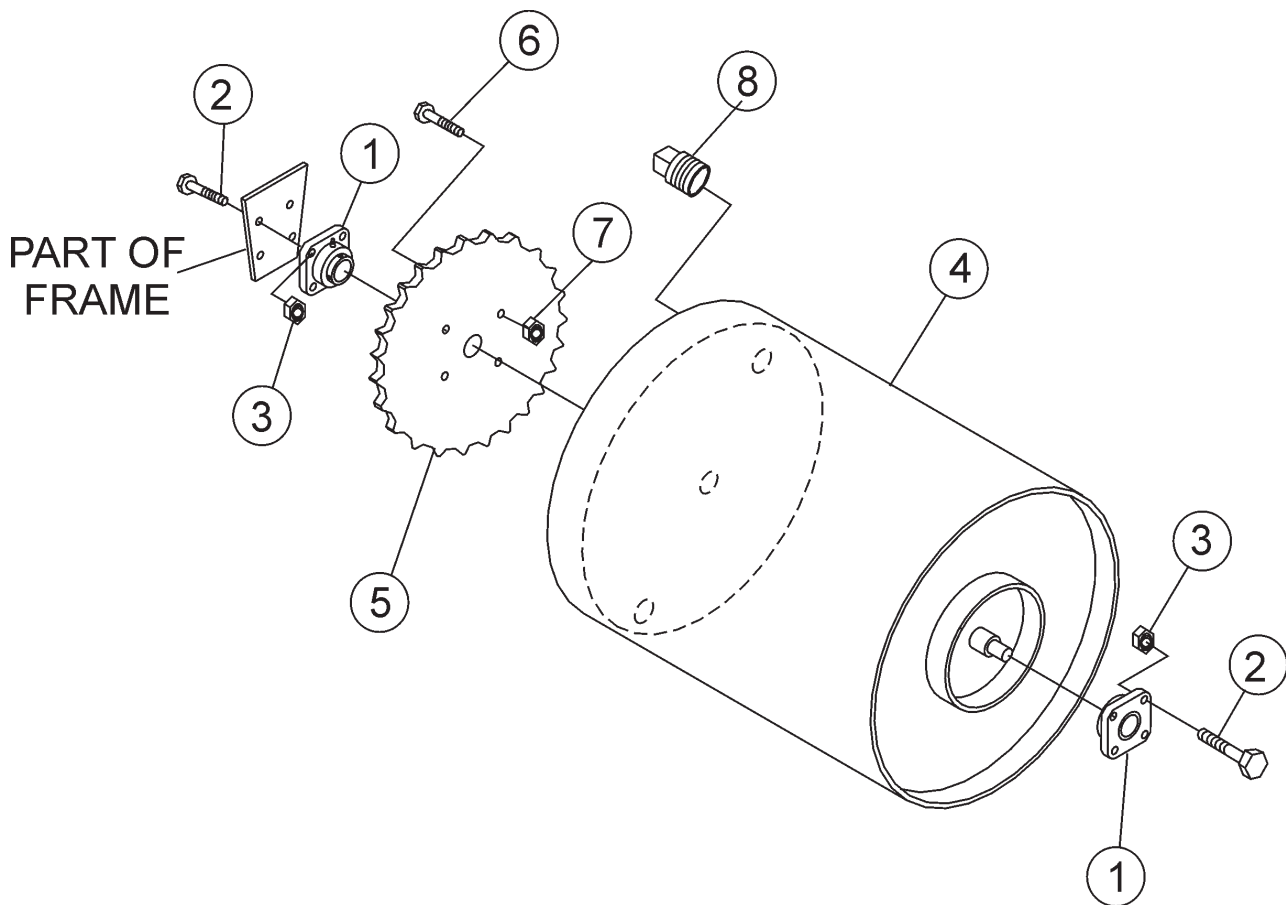

## REAR DRUM ASSY.

<u>NO</u>	<u>PART NO</u>	<u>PART NAME</u>	<u>QTY.</u>	<u>REMARK</u>
1	530296	BEARING	2	
2	492390	SCREW, CAP 7/16"	8	
3	505081	HEXNUT 7/16"	8	
4	530297	FRONT ROLL UNIT	1	
5	24194-001	SPROCKET - 70 TOOTH	1	
6	530298	SCREW, HEX 5/8"	4	
7	EM969023	NUT, HEX 5/8"	4	
8	491214	PIPE PLUG	2	

# R2000H — DRIVE SYSTEM ASSY.

## DRIVE SYSTEM ASSY.

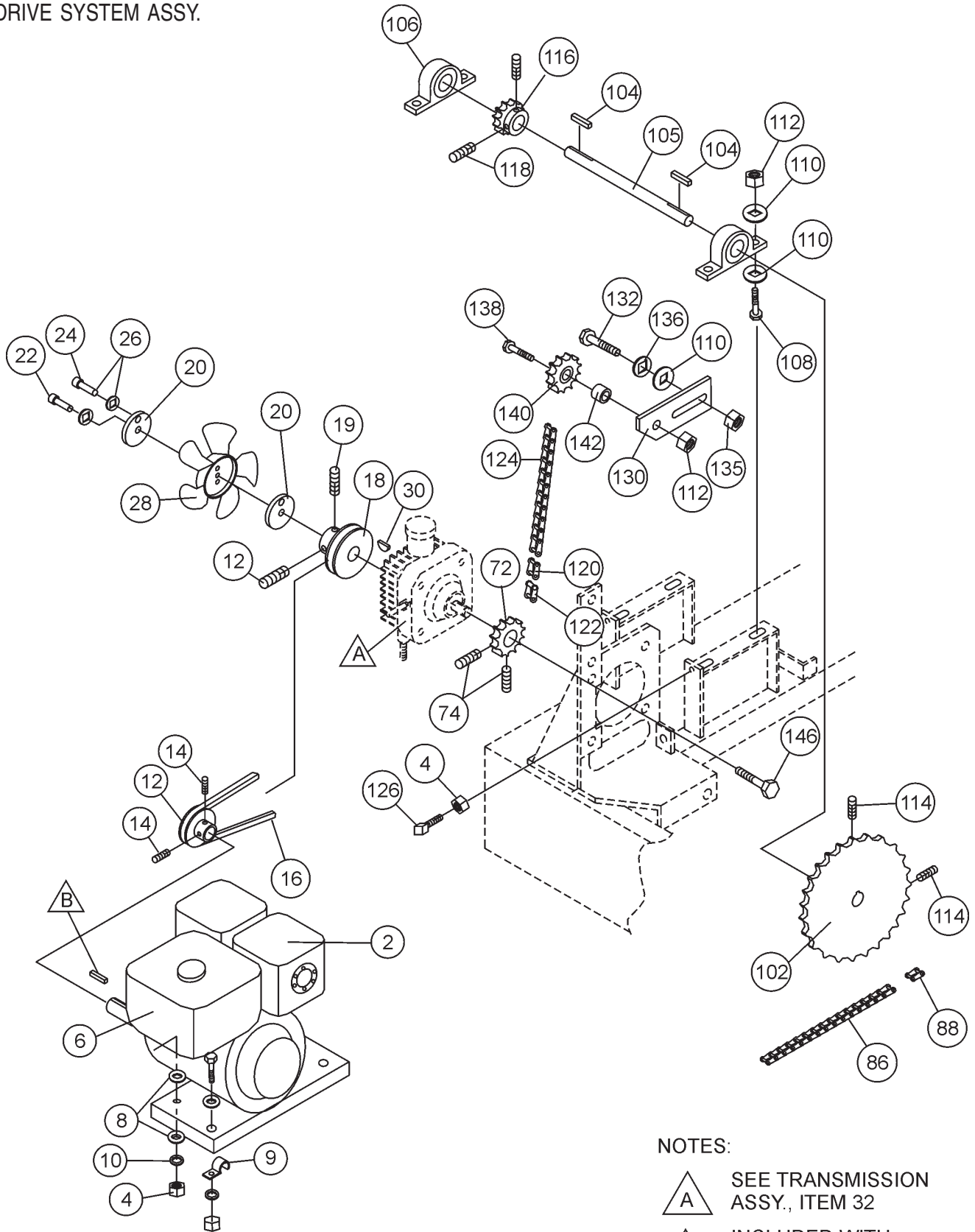

### NOTES:



SEE TRANSMISSION  
ASSY., ITEM 32



INCLUDED WITH  
ENGINE, ITEM 2

# R2000H — DRIVE SYSTEM ASSY.

## DRIVE SYSTEM ASSY.

<u>NO</u>	<u>PART NO</u>	<u>PART NAME</u>	<u>QTY.</u>	<u>REMARKS</u>
2	GX240K1QAE2	HONDA GX240K1QAE2	1	
4	492554	NUT, HEX 3/8"	4	
6	492378	BOLT, 3/8" x 1-3/4" G5	4	
8	512193	WASHER, FLAT 3/8"	7	
9	EM502571	CLIP	1	
10	0166 A	WASHER, LOCK 3/8"	4	
12	530311	PULLEY, ENGINE 6 MM	1	
14	492467	SCREW, ALLEN 5/16" x 3/8"	2	
16	503837	V-BELT A-43	1	
18	530312	PULLEY, PUMP .5 MM	1	
19	513489	SCREW, SET 1/4" x 3/8"	2	
20	530313	WASHER, 1/4" FAN SECURING	2	
22	492256	SCREW, ALLEN HEAD 1/4" x 1" 20-NC	1	
24	530314	SCREW, ALLEN HEAD 1/4" x 1" 28-NF	1	
26	210402	WASHER, LOCK 1/4"	2	
28	530315	FAN, BLADE	1	
30	491759	KEY, WOODRUFF 1/8" x 1/2	2	
72	530326	DRIVE GEAR 10 TEETH, TRANSMISSION	1	
74	255061	SCREW, SET 1/4" NC x 1/4"	2	
86	29344-501	CHAIN LARGE SPROCKET	1	
88	530329	CHAIN MASTER LINK .....	1	USED WITH ITEM 86
102	530331	SPROCKET 72 TEETH	1	
104	500432	KEY, SQUARE 3/8" X 50 MM	1	
105	530384	PINION SHAFT	1	
106	530332	PILLOW BLOCK BEARING	2	
108	492395	SCREW 1/2" NC x 1-3/4" G5	4	
110	621	WASHER 1/2" ESP	8	
112	492584	NUT, NYLOCK 1/2" NC	4	
114	492471	SCREW, ALLEN 3/8" NC X 1/2"	2	
116	530333	SPROCKET 12 TEETH SHAFT	1	
118	492470	SCREW, ALLEN 3/8" NC 3/8"	2	
120	530335	CHAIN LINK .....	1	USED WITH ITEM 124
122	530336	CHAIN MASTER LINK .....	1	USED WITH ITEM 124
124	24675-501	CHAIN SMALL SPROCKET	1	
126	492486	SQUARE-HEAD SCREW 3/8" NC X 1-3/4"	1	
128	1456	NUT, HEX 3/8" NC	2	
130	530337	PLATE, SUPPORT TENSION	1	
132	509165	SCREW, HEX 1/2" NC x 2-1/4" G5	2	
134	621	WASHER 1/2" ESP	2	
135	6109160	NUT, HEX 1/2" NC G5	1	
136	6109180	WASHER, LOCK 1/2"	2	
138	492397	SCREW, HEX 1/2" NC X 2-1/2" G5	1	
140	530338	SPROCKET 15 TEETH, IDLER	1	
142	530339	SPACER, TENSION	1	
144	492584	NUT, NYLOCK 1/2" NC	1	
146	490166	BOLT, HHCS, 3/8" X 3-1/2" G5	1	

# R2000H — TRANSMISSION ASSY.

## TRANSMISSION ASSY.

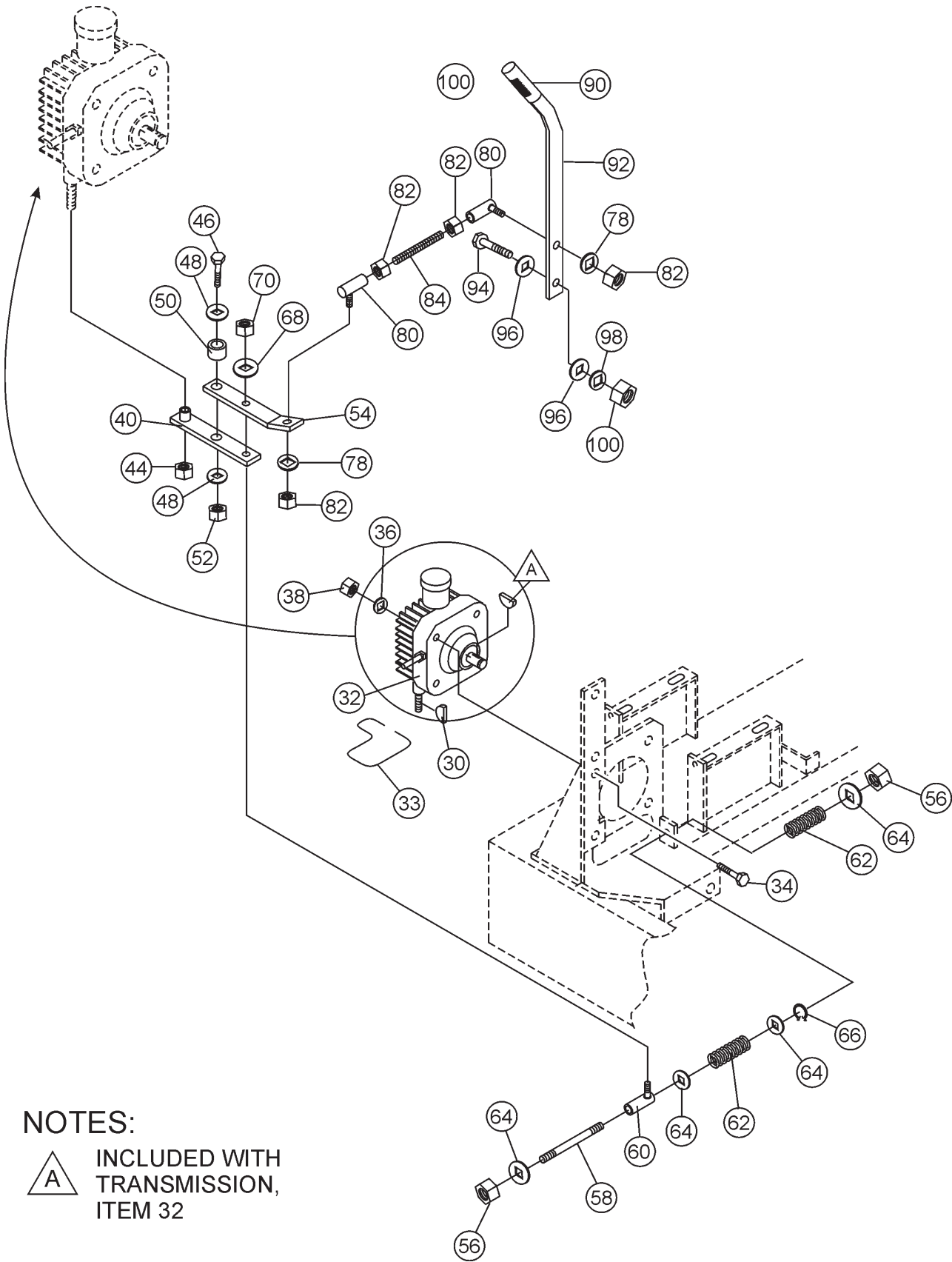

**NOTES:**



INCLUDED WITH  
TRANSMISSION,  
ITEM 32



## R2000H — TRANSMISSION ASSY.

### TRANSMISSION ASSY.

<u>NO</u>	<u>PART NO</u>	<u>PART NAME</u>	<u>QTY.</u>	<u>REMARKS</u>
30	EM491759	KEY, WOODRUFF 1/8" x 1/2	2	
32	EM510971	PUMP, HYDROSTATIC	1	
33	505832	LEVER, FREE FLOW RELIEF	1	
34	EM963064	SCREW, 3/8" NC x 3-1/2" G5 16-NC	3	
36	504679	WASHER, FLAT 3/8"	4	
38	EM969013	NUT, LOCK 3/8"	4	
40	530316	SHIFT ARM ASSY.	1	
44	EM969012	NUT, NYLOCK 3/8" 16 NC	1	
46	492357	BOLT, G8	1	
48	492596	WASHER, FLAT 1/4"	2	
50	530320	SPACER	1	
52	2101428	NUT, NYLOCK 1/4" NC 20-NC	1	
54	530321	SHIFT ARM EXTENSION	1	
56	EM969013	NUT, HEX 3/8" NC	2	
58	530322	ADJUSTMENT ROD	1	
60	530323	BALL-JOINT	1	
62	530324	SPRING, COMPRESSION	1	
64	3019092	WASHER, FLAT 3/8"	5	
66	530325	SNAP RING	1	
68	EM923023	WASHER, FLAT 5/16"	1	
70	2105164	NUT, NYLOCK 5/16"	1	
78	2101402	WASHER, LOCK 1/4"	2	
80	516487	BALL JOINT	2	
82	6904	NUT, HEX 1/4-28	4	
84	24556-001	ROD, ADJUSTMENT	1	
90	15081	HAND GRIP	1	
92	530330	SHIFT HANDLE	1	
94	EM963692	SCREW, HEX 1/2" NC x 1-1/2" G5	1	
96	504322	WASHER, FLAT 1/2 "	2	
98	6109180	WASHER, LOCK 1/2"	1	
100	492584	NUT, NYLOCK 1/2"	1	

# R2000H — WATER SYSTEM ASSY.

WATER SYSTEM ASSY.

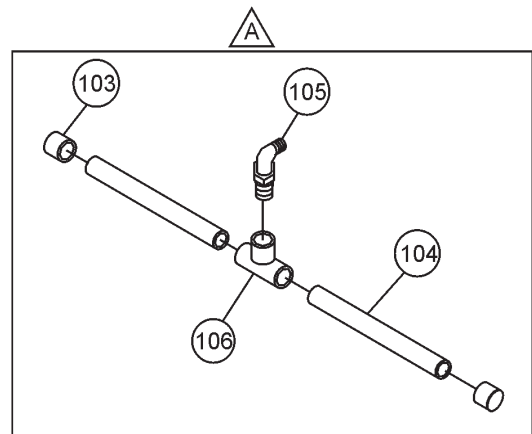
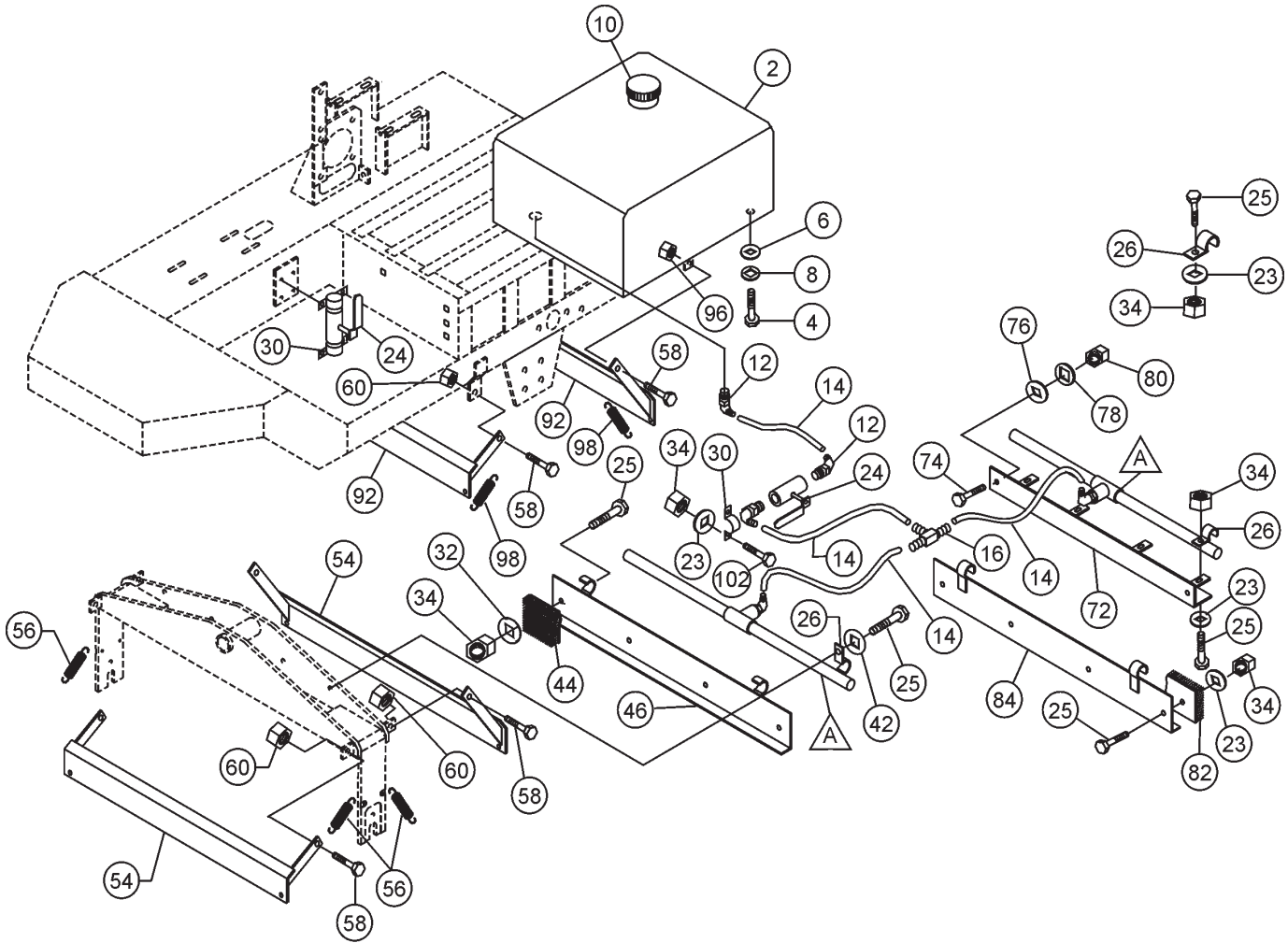

# R2000H — WATER SYSTEM ASSY.

## WATER SYSTEM ASSY.

<u>NO</u>	<u>PART NO</u>	<u>PART NAME</u>	<u>QTY.</u>	<u>REMARK</u>
2	530460	TANK, WATER	1	
4	492438	BOLT, C/H 5/16"NF X 1" G5	4	
6	EM923023	WASHER 5/16" FLAT W	4	
8	EM923343	WASHER 5/16" LOCK	4	
10	509249	CAP, PLASTIC WATER TANK	1	
12	506071	FITTING, ELBOW 1/2"	3	
14	504163	HOSE, VINYL WATER	2	
16	513379	FITTING, TEE 1/2" NYLON	1	
23	492596	WASHER 1/4" FLAT G.	19	
24	491237	VALVE, WATER FLOW 1/2"	1	
25	492356	BOLT, C/H 1/4"NC X 3/4"	19	
26	EM502571	CLIP	4	
30	511431	SUPPORT CLAMP, TUBE 3/4"	2	
34	492581	NUT, 1/4"	19	
42	492622	WASHER 1/4" LOCK	4	
44	530305	COCOA MAT, FRONT	1	
46	530303	SCRAPER, FRONT DRUM	1	
54	530307	SCRAPER, FRONT DRUM REAR	2	
56	530308	EXTENSIONS, FRONT DRUM SPRING	4	
58	492393	BOLT, C/H 1/2"NC X 1.1/4"	8	
60	492584	NUT, 1/2"	8	
72	530309	SUPPORT, WATER TUBE	1	
74	EM963610	BOLT, C/H 3/8"NC X 1.1/4"	2	
76	3019092	WASHER, FLAT 3/8"	4	
78	0166 A	WASHER, LOCK 3/8"	2	
80	1456	NUT, HEX 3/8"	2	
82	530306	COCOA MAT, REAR	1	
84	530304	SCRAPER, REAR DRUM	1	
92	530310	SCRAPER, REAR DRUM REAR	2	
98	530308	EXTENSIONS, REAR DRUM SPRING	4	
102	492357	BOLT, C/H 1/4"NC X 1"G8"	4	
103	508610	CAP PVC 13 MM	2	
104	506072	PVC TUBE, FRONT DRUM 1/2" x 17" .....	2	CUT TUBE LENGTH TO 11.75"
104	506072	PVC TUBE, REAR DRUM 1/2 x 17" .....	2	CUT TUBE LENGTH TO 15.5"
105	506071	ELBOW PVC	1	
106	513869	TEE PVC TUBE 1/2"	1	

# HONDA GX240K1QAE2 ENGINE — AIR CLEANER ASSY.

AIR CLEANER ASSY.

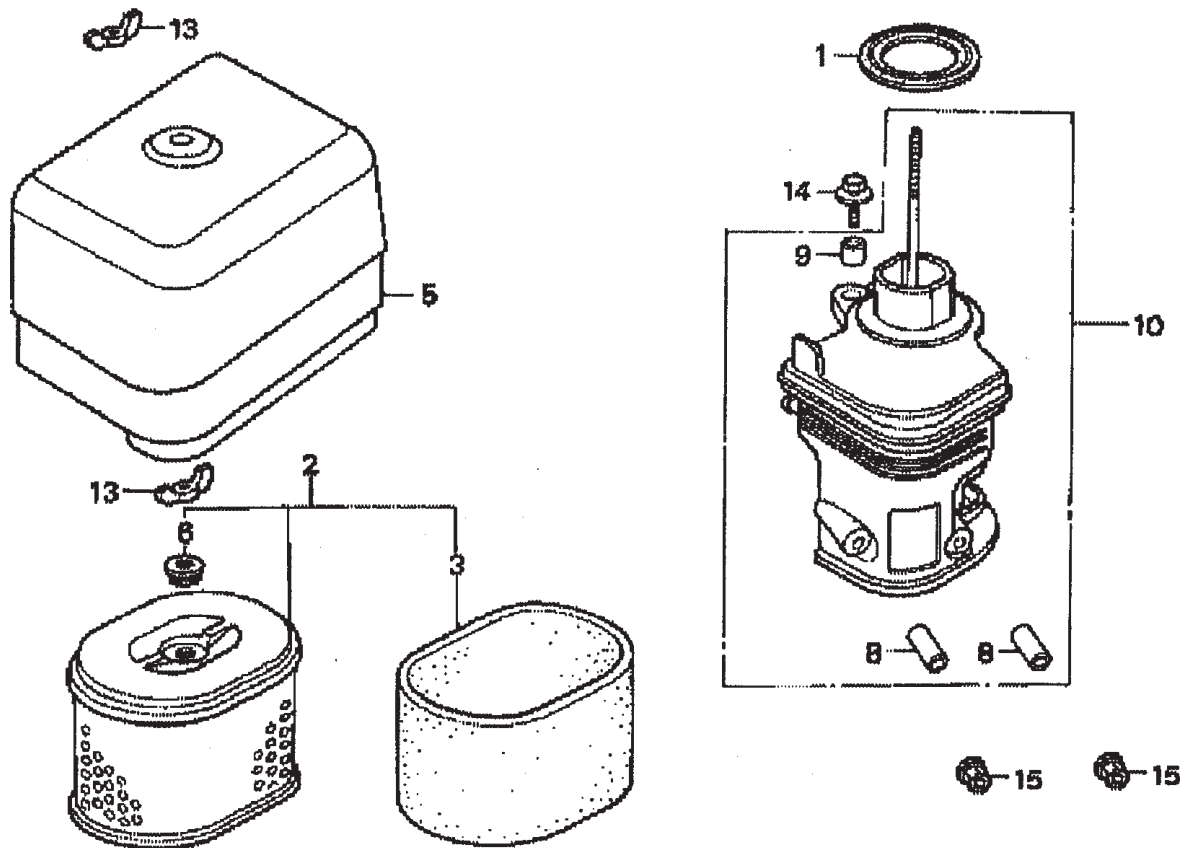

## HONDA GX240K1QAE2 ENGINE — AIR CLEANER ASSY.

AIR CLEANER ASSY.

<u>NO.</u>	<u>PART NO.</u>	<u>PART NAME</u>	<u>QTY.</u>	<u>REMARKS</u>
1	16271ZE2000	GASKET, ELBOW	1	
2	17210ZE2822	ELEMENT, AIR CLEANER, DUAL .....	1 .....	INCLUDES ITEMS W/*
3*	17218ZE2505	FILTER, OUTER	1	
5	17231ZH9820	COVER, AIR CLEANER	1	
6	17232891000	GROMMET, AIR CLEANER	1	
8%	17238ZE2310	COLLAR, AIR CLEANER	2	
9%	17239ZE1000	COLLAR B, AIR CLEANER	1	
10	17410ZE2020	ELBOW COMP., AIR CLEANER .....	1 .....	INCLUDES ITEMS W/%
13	90325044000	WINGNUT, TOOL BOX SETTING	2	
14	90009ZE2003	BOLT- WASHER 6 X 22	1	
15	9405006000	NUT, FLANGE 6MM	2	

# HONDA GX240K1QAE2 ENGINE — CAMSHAFT ASSY.

CAMSHAFT ASSY.

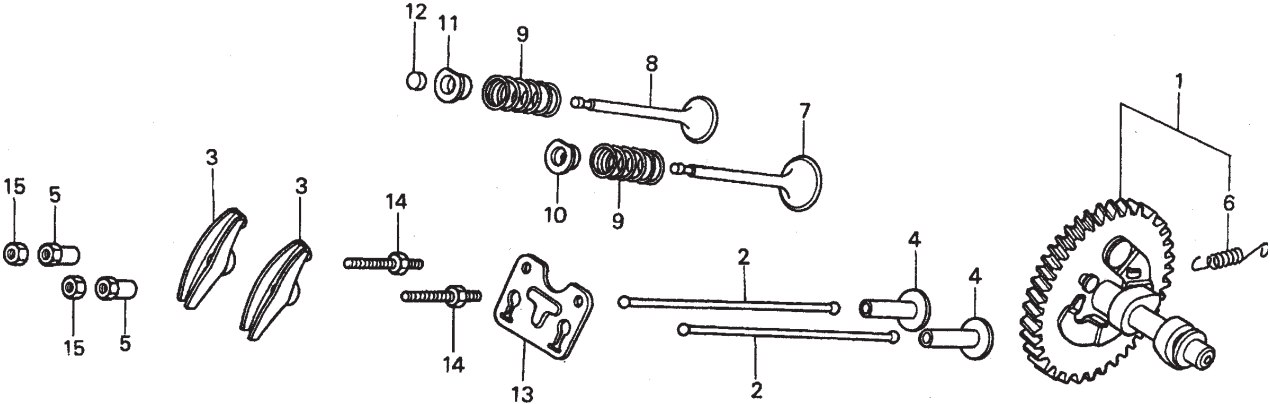

# HONDA GX240K1QAE2 ENGINE — CAMSHAFT ASSY.

## CAMSHAFT ASSY.

<u>NO.</u>	<u>PART NO.</u>	<u>PART NAME</u>	<u>QTY.</u>	<u>REMARKS</u>
1	14100ZE2W01	CAMSHAFT ASSY. ....	1	INCLUDES ITEMS W/*
2	14410ZE2013	ROD PUSH	2	
3	14431ZE2010	ARM VALVE ROCKER	2	
4	14441ZE2000	LIFTER VALVE	2	
5	14451ZE1013	PIVOT ROCKER ARM	2	
6*	14568ZE1000	SPRING, WEIGHT RETURN	1	
7	14711ZE2000	VALVE, IN.	1	
8	14721ZE2000	VALVE, EX.	1	
9	14751ZE2003	SPRING, VALVE	2	
10	14771ZE2000	RETAINER, IN. VALVE SPRING	1	
11	14773ZE2000	RETAINER, EX. VALVE SPRING	1	
12	14781ZE2000	ROTATOR, VALVE	1	
13	14791ZE2010	PLATE, PUSH ROD GUIDE	1	
14	90012ZE0010	BOLT, PIVOT 8MM	2	
15	90206ZE1000	NUT, PIVOT ADJ.	2	

# HONDA GX240K1QAE2 ENGINE — CARBURETOR ASSY.

CARBURETOR ASSY.

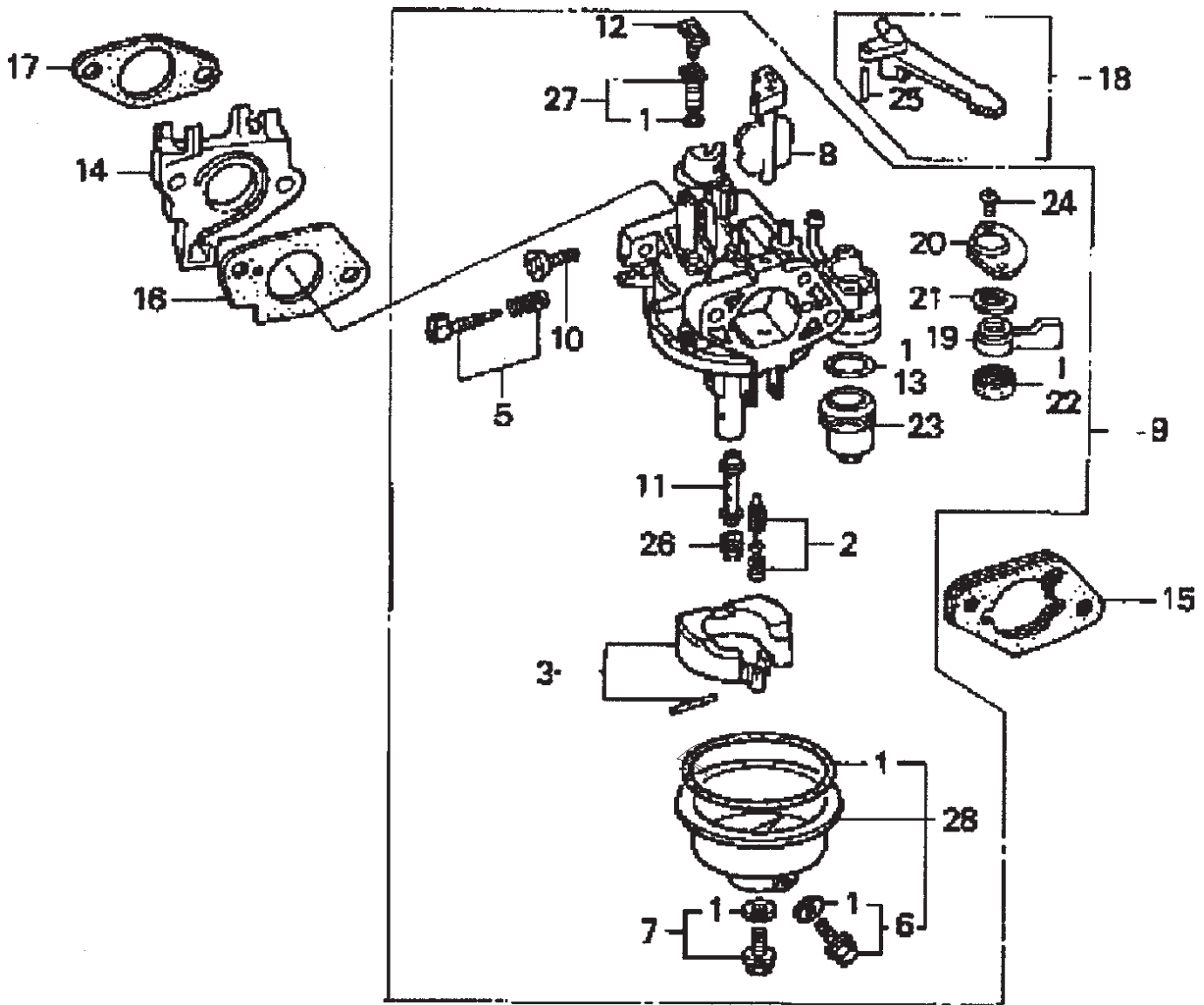



# HONDA GX240K1QAE2 ENGINE — CARBURETOR ASSY.

## CARBURETOR ASSY.

<u>NO.</u>	<u>PART NO.</u>	<u>PART NAME</u>	<u>QTY.</u>	<u>REMARKS</u>
1* %+	16010ZE2812	GASKET SET	1	
2*	16011ZA0931	VALVE SET, FLOAT	1	
3*	16013ZA0931	FLOAT SET	1	
5*	16016ZHW01	SCREW SET	1	
6*+	16024ZE1811	SCREW SET, DRAIN	1	
7*	16028ZE0005	SCREW SET B	1	
8*	16028ZE2005	CHOKE SET	1	
9	16100ZE2W71	CARBURETOR ASSY.....	1	INCLUDES ITEMS W/*
10*	16124ZE0005	SCREW, THROTTLE STOP	1	
11*	16166ZE2W70	NOZZLE, MAIN	1	
12*	16172ZE3W10	COLLAR, SET	1	
13*	16173001004	O-RING	1	
14	16211ZE2000	INSULATOR, CARBURETOR	1	
15	16220ZA0702	SPACER COMP., CARBURETOR	1	
16	16221ZA0800	GASKET, CARBURETOR	1	
17	16223ZA0800	GASKET, INSULATOR	1	
18	16610ZE1000	LEVER COMP., CHOKE, STD. ....	1	INCLUDES ITEMS W/■
19*	16953ZE1812	LEVER, VALVE	1	
20*	16954ZE1811	PLATE, LEVER SETTING	1	
21*	16956ZE1811	SPRING, VALVE LEVER	1	
22*	16957ZE1812	GASKET, VALVE	1	
23*	16967ZE0811	CUP, FUEL STRAINER	1	
24	93500030060H	SCREW, PAN 3 X 6	2	
25■	9430520122	PIN, SPRING 2 X 12	1	
26	99101ZH80820	JET, MAIN #82, OPTIONAL	1	
26	99101ZH80850	JET, MAIN #85, OPTIONAL	1	
26*	99101ZH80880	JET, MAIN #88	1	
27*	99204ZE20400	JET SET, PILOT #40 .....	1	INCLUDES ITEMS W/ %
28*	16015ZE8005	CHAMBER SET, FLOAT .....	1	INCLUDES ITEMS W/+

# HONDA GX240K1QAE2 ENGINE — CONTROL ASSY.

CONTROL ASSY.

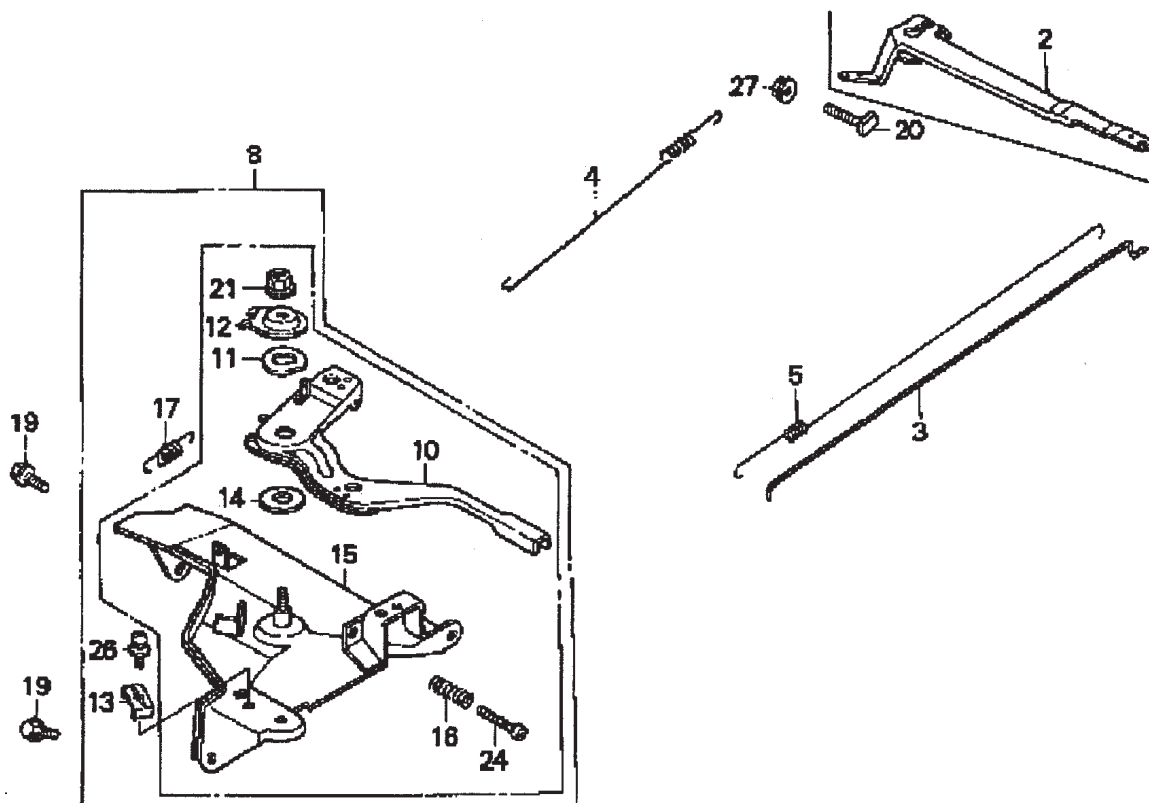

# HONDA GX240K1QAE2 ENGINE — CONTROL ASSY.

CONTROL ASSY.

<u>NO.</u>	<u>PART NO.</u>	<u>PART NAME</u>	<u>QTY.</u>	<u>REMARKS</u>
2	16551ZE2000	ARM, GOVERNOR	1	
3	16555ZE2000	ROD, GOVERNOR	1	
4	16561ZE2000	SPRING, GOVERNOR	1	
5	16562ZE2000	SPRING, THROTTLE RETURN	1	
8	16570ZE2W20	CONTROL ASSY., REMOTE .....	1	INCLUDES ITEMS W/*
10*	16571ZE2W00	LEVER, CONTROL	1	
11*	16574ZE1000	SPRING, LEVER	1	
12*	16575ZE2W00	WASHER, CONTROL LEVER	1	
13*	16576891000	HOLDER, CABLE	1	
14*	16578ZE1000	SPACER, CONTROL LEVER	1	
15*	16581ZE2W00	BASE COMP., CONTROL	1	
16*	16584883300	SPRING, CONTROL ADJUSTING	1	
17*	16592883310	SPRING, CABLE RETURN	1	
19	90013883000	BOLT, FLANGE 6 X 12 CT200	2	
20	90015ZE5010	BOLT, GOVERNOR ARM	1	
21	90114SA0000	NUT, SELF-LOCK 6MM	1	
24*	93500050280A	SCREW, PAN 5 X 28	1	
26*	93500050160A	SCREW, PAN 5 X 16	1	
27	9405006000	NUT, FLANGE 6MM	1	

# HONDA GX240K1QAE2 ENGINE — CRANKCASE COVER ASSY.

CRANKCASE COVER ASSY.

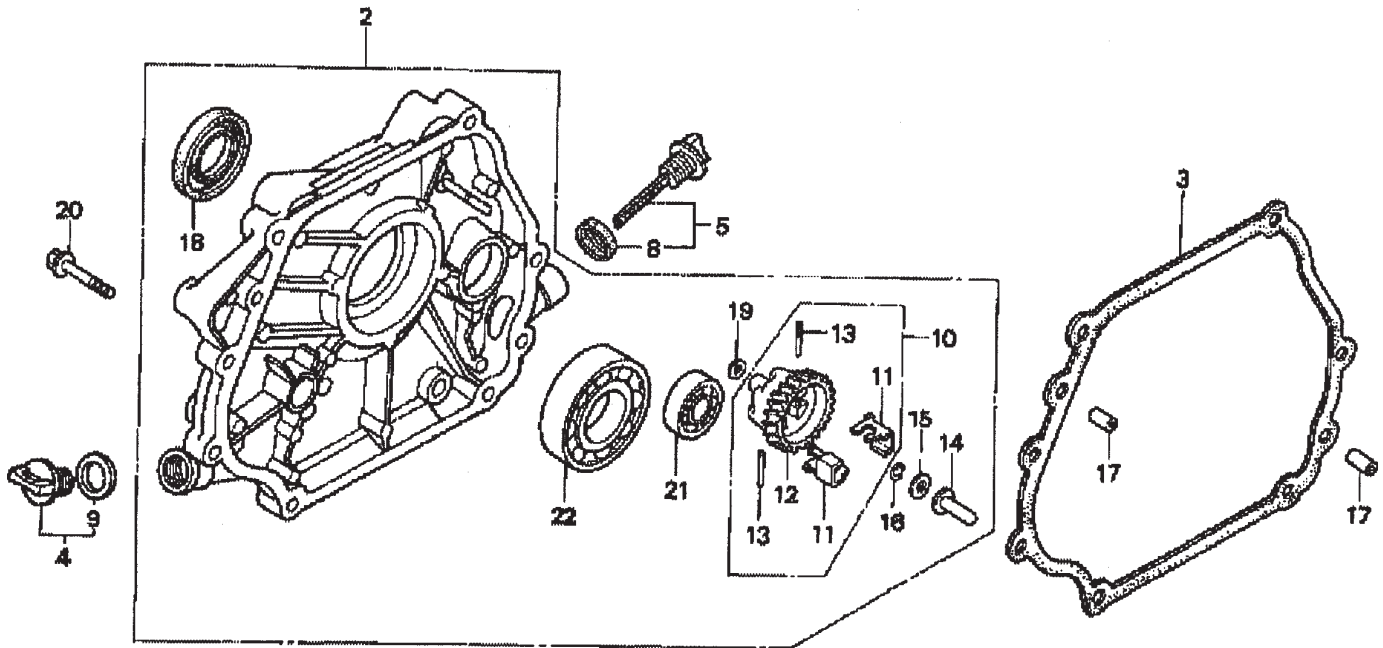

# HONDA GX240K1QAE2 ENGINE — CRANKCASE COVER ASSY.

## CRANKCASE COVER ASSY.

<u>NO.</u>	<u>PART NO.</u>	<u>PART NAME</u>	<u>QTY.</u>	<u>REMARKS</u>
2	11400ZE2601	COVER ASSY., CRANKCASE .....	1 .....	INCLUDES ITEMS W/*
3	11381ZE2801	GASKET, CASE COVER	1	
4	15600ZG4003	CAP ASSY., OIL FILLER .....	1 .....	INCLUDES ITEMS W/%
5	15600735003	CAP ASSY., OIL FILLER .....	1 .....	INCLUDES ITEMS W/+
8+	15625ZE1000	GASKET, OIL FILLER CAP	1	
9%	15625ZE1003	GASKET, OIL FILLER CAP	1	
10*	16510ZE2811	GOVERNOR ASSY., BALANCER .....	1 .....	INCLUDES ITEMS W/\$
11*\$	16511ZE2000	WEIGHT, GOVERNOR	2	
12*\$	16512ZE2811	HOLDER, GOVERNOR WEIGHT	1	
13*\$	16513ZE2000	PIN, GOVERNOR WEIGHT	2	
14*	16531ZE2000	SLIDER, GOVERNOR	1	
15*	90473147000	WASHER 6 X 16	1	
16*	90602ZE1000	CLIP, GOVERNOR HOLDER	1	
17	90701HC4000	PIN, DOWEL 8 X 12	2	
18*	91201890003	OIL SEAL 30 X 46 X 8	1	
19*	9410106800	WASHER, PLAIN 6MM	1	
20	957010803500	BOLT, FLANGE 8 X 35	7	
21*	961006202000	BEARING, RADIAL BALL 6202	1	
22*	961006206000	BEARING, RADIAL BALL 6206		

# HONDA GX240K1QAE2 ENGINE — CRANKSHAFT ASSY.

CRANKSHAFT ASSY.

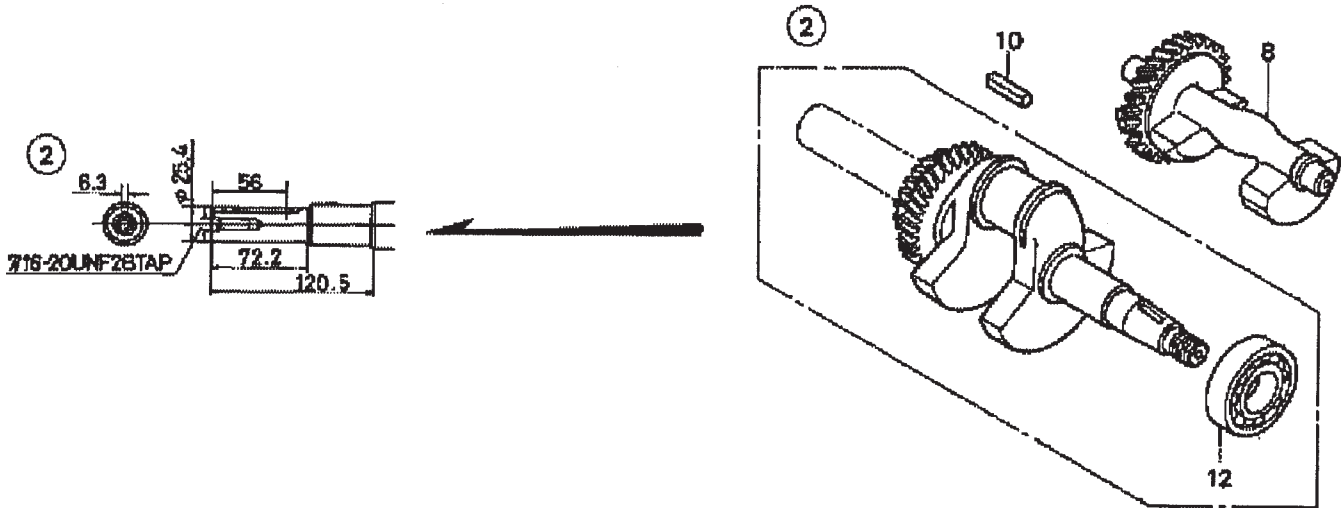

# HONDA GX240K1QAE2 ENGINE — CRANKSHAFT ASSY.

## CRANKSHAFT ASSY.

<u>NO.</u>	<u>PART NO.</u>	<u>PART NAME</u>	<u>QTY.</u>	<u>REMARKS</u>
2	13320ZE2601	CRANKSHAFT COMP., Q- TYPE .....	1 .....	INCLUDES ITEMS W/*
8	13351ZE2010	WEIGHT, BALANCER	1	
10	90745ZE2600	KEY 6.3 X 6.3 X 43	1	
12*	961006206000	BEARING, RADIAL BALL 6206	1	

# HONDA GX240K1QAE2 ENGINE — CYLINDER BARREL ASSY.

CYLINDER BARREL ASSY.

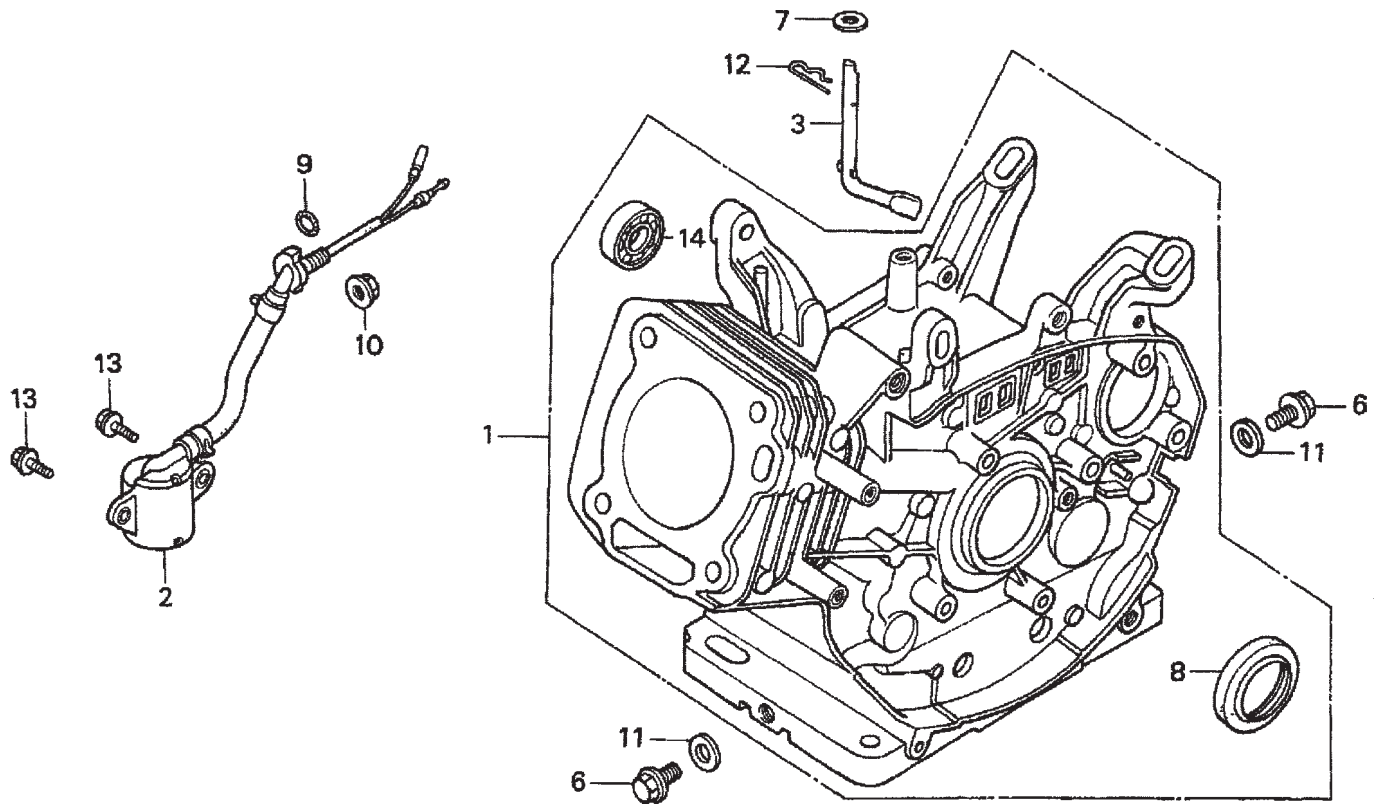



# HONDA GX240K1QAE2 ENGINE — CYLINDER BARREL ASSY.

## CYLINDER BARREL ASSY.

<u>NO.</u>	<u>PART NO.</u>	<u>PART NAME</u>	<u>QTY.</u>	<u>REMARKS</u>
1	12000ZE2844	CYLINDER ASSY., BALANCER + OIL ALERT	1	INCLUDES ITEMS W/*
2	15510ZE2043	SWITCH ASSY., OIL LEVEL	1	
3	16541ZE2010	SHAFT, GOVERNOR ARM	1	
3	16541ZE2010	SHAFT, GOVERNOR ARM	1	
6	90131896650	BOLT, DRAIN PLUG	2	
7	90446KE1000	WASHER 8.2 X17X0.8	1	
8*	91201890003	OIL SEAL 30X46X8	1	
9	91353671003	O-RING	1	
10	9405010000	NUT, FLANGE 10MM	1	
11	9410912000	WASHER, DRAIN PLUG 12MM	2	
12	9425110000	PIN, LOCK 10MM	1	
13	957010601200	BOLT, FLANGE 6X12	2	
14*	961006202000	BEARING, RADIAL BALL 6202	1	

# HONDA GX240K1QAE2 ENGINE — CYLINDER HEAD ASSY.

CYLINDER HEAD ASSY.

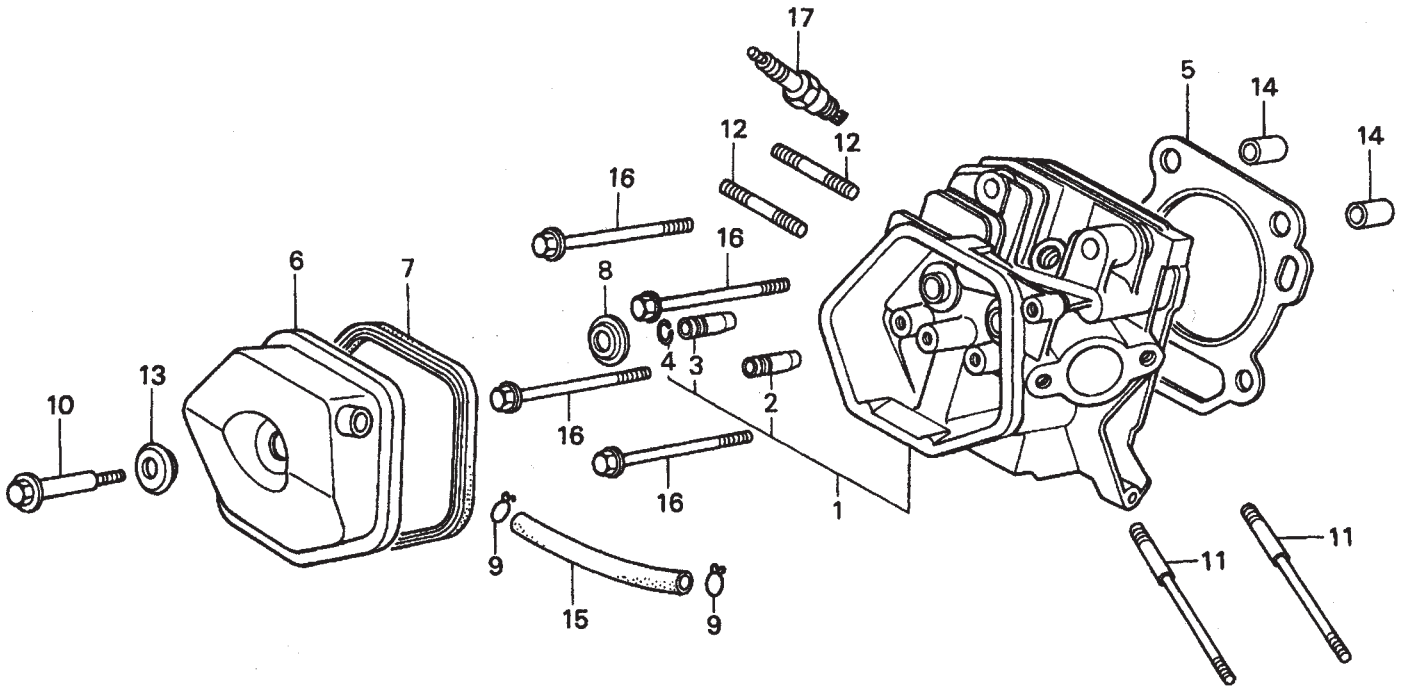

# HONDA GX240K1QAE2 ENGINE — CYLINDER HEAD ASSY.

## CYLINDER HEAD ASSY.

<u>NO.</u>	<u>PART NO.</u>	<u>PART NAME</u>	<u>QTY.</u>	<u>REMARKS</u>
1	12200ZH9000	CYLINDER HEAD COMP. ....	1	INCLUDES ITEMS W/*
2*	12204ZE2306	GUIDE, VALVE, OS, OPTIONAL	1	
3*	12205ZE2305	GUIDE, EX. VALVE, OS, OPTIONAL	1	
4*	12216ZE2300	CLIP, VALVE GUIDE	1	
5	12251ZE2800	GASKET, CYLINDER HEAD	1	
6	12310ZE2020	COVER COMP., HEAD	1	
7	12391ZE2020	GASKET, CYLINDER HEAD COVER	1	
8	14775ZE2010	SEAT, VALVE SPRING	1	
10	90014ZE2000	BOLT, HEAD COVER	1	
11	90042ZE2000	BOLT, STUD 8X123	2	
12	92900080320E	BOLT 2, STUD 8X32	2	
13	90441ZE2010	WASHER COMP., HEAD COVER	1	
14	9430112200	PIN A, DOWEL 12X20	2	
15	950051100130M	BULK HOSE, VACUUM 11X1000, 11X100	1	
16	957011008000	BOLT, FLANGE 10X80	4	
17	9807955846	SPARK PLUG, BPR5ES, NGK	1	
17	9807955855	SPARK PLUG, W16EPR-U, DENSO, OPTIONAL	1	
17	9807956855	SPARK PLUG, W20EPR-U, DENSO	1	

# HONDA GX240K1QAE2 ENGINE — FAN COVER ASSY.

FAN COVER ASSY.

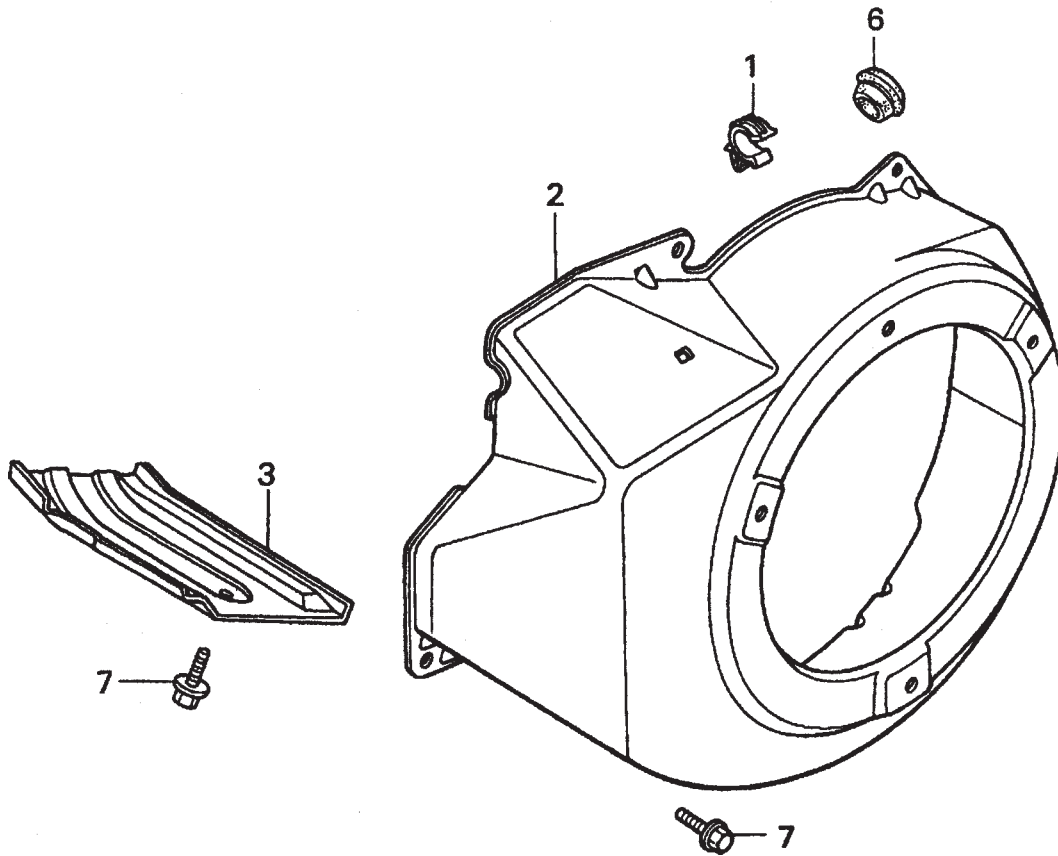

# HONDA GX240K1QAE2 ENGINE — FAN COVER ASSY.

FAN COVER ASSY.

<u>NO.</u>	<u>PART NO.</u>	<u>PART NAME</u>	<u>QTY.</u>	<u>REMARKS</u>
1	16731ZE2003	CLIP, TUBE	1	
2	19610ZE2010ZA	COVER COMP., FAN *R8* BRIGHT RED	1	
3	19631ZE2D00	SHROUD	1	
6	81329567020	GROMMET, DRAIN HOLE	1	
7	90013883000	BOLT, FLANGE 6X12, CT200	6	
9	90684ZA0601	CLIP, WIRE HARNESS	1	

# HONDA GX240K1QAE2 ENGINE — FLYWHEEL ASSY.

FLYWHEEL ASSY.

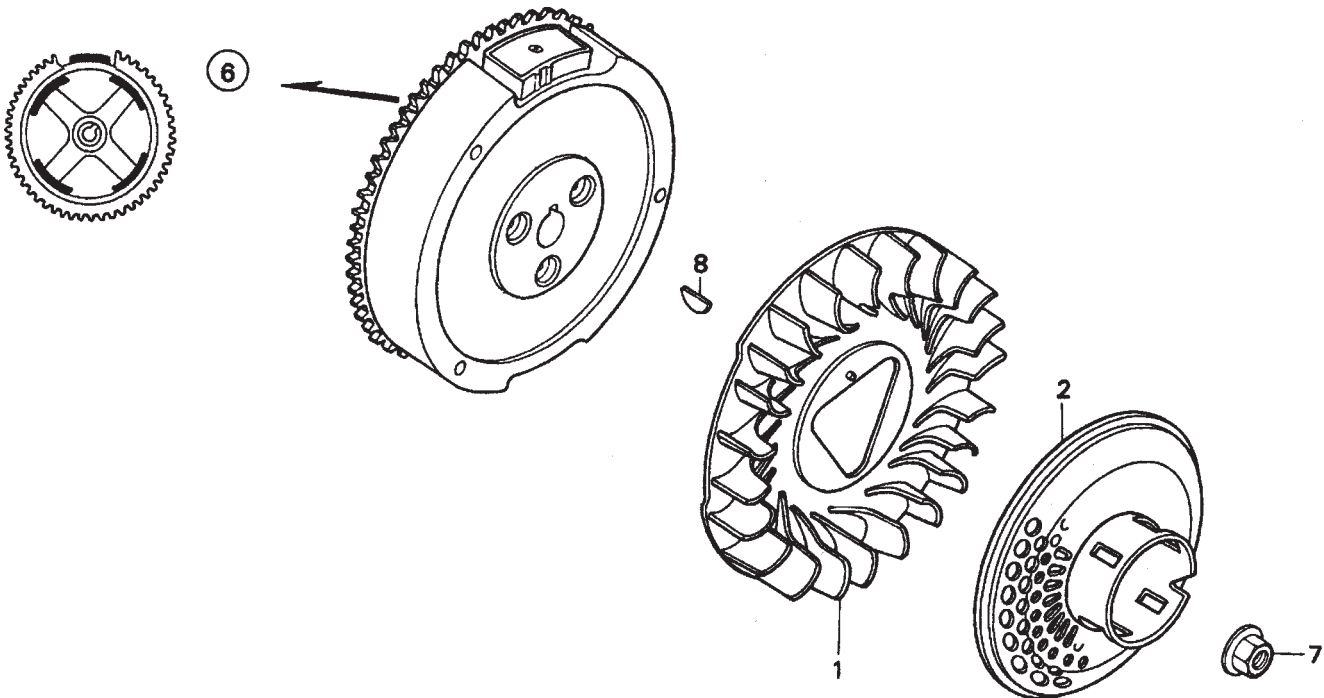

# HONDA GX240K1QAE2 ENGINE — FLYWHEEL ASSY.

FLYWHEEL ASSY.

<u>NO.</u>	<u>PART NO.</u>	<u>PART NAME</u>	<u>QTY.</u>	<u>REMARKS</u>
1	19511ZE2000	FAN, COOLING	1	
2	28450ZE2W11	PULLEY COMP., STARTER, SCREEN GRID	1	
6	31100ZE2832	FLYWHEEL COMP.	1	
7	90201ZE3V00	NUT, SPECIAL 16MM	1	
8	90741ZE2000	KEY, SPECIAL WOODRUFF 25X18	1	

# HONDA GX240K1QAE2 ENGINE — FUEL TANK ASSY.

FUEL TANK ASSY.

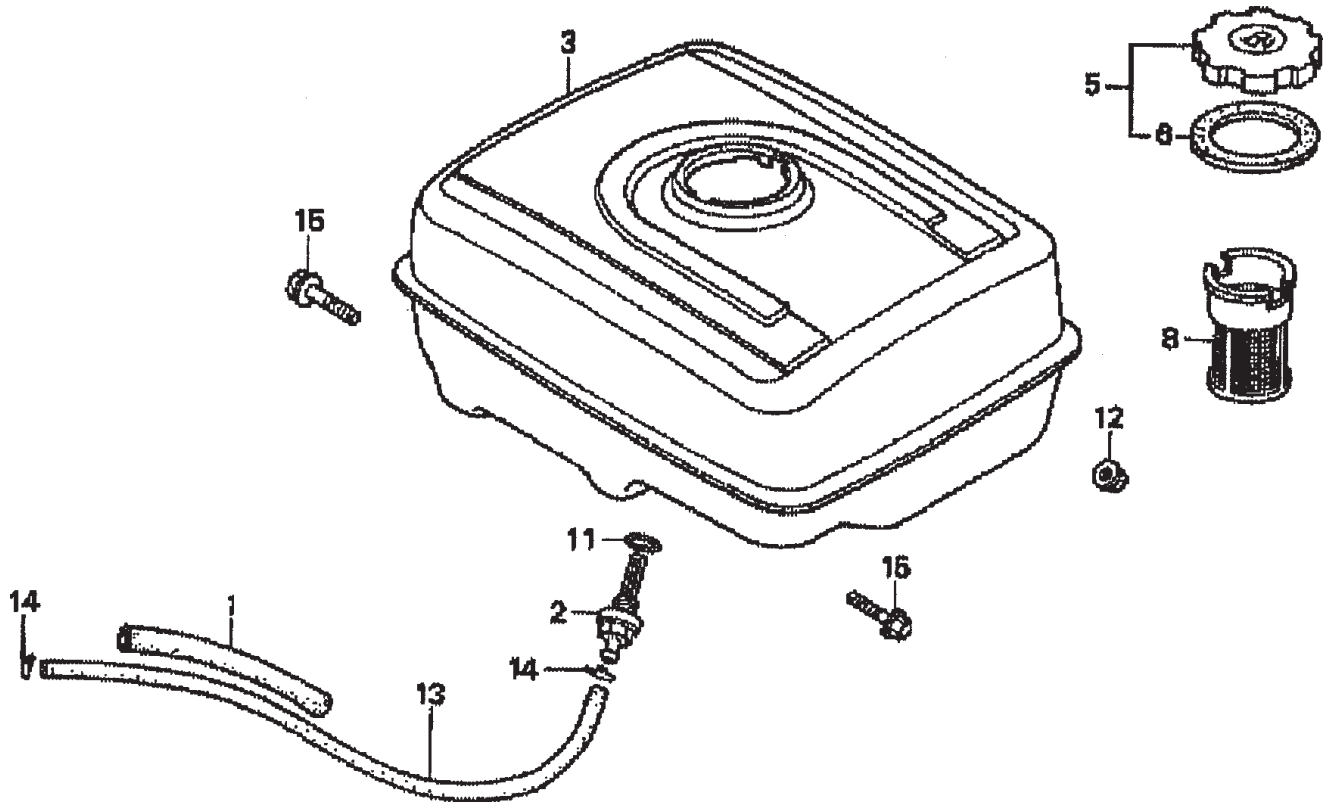



# HONDA GX240K1QAE2 ENGINE — FUEL TANK ASSY.

FUEL TANK ASSY.

<u>NO.</u>	<u>PART NO.</u>	<u>PART NAME</u>	<u>QTY.</u>	<u>REMARKS</u>
1	16854ZH8000	RUBBER SUPPORTER 107MM	1	
2	16955ZE1000	JOINT, FUEL TANK	1	
3	17510ZE2010ZA	TANK COMP., FUEL *NH1*, MC KINLEY WHITE	1	
5	17620ZH7023	CAP COMP., FUEL FILLER .....	1	INCLUDES ITEMS W/*
6*	17631ZH7003	GASKET, FUEL FILLER CAP	1	
8	17672ZE2W01	FILTER, FUEL	1	
11	91353671003	O-RING 14MM, ARAI	1	
12	9405008000	NUT, FLANGE 8MM	2	
13	950014500360M	BULK HOSE, FUEL 4.5X3000, 4.5X222	1	
14	9500202080	CLIP, TUBE, B8	2	
15	957010802500	BOLT, FLANGE 8X25	2	

# HONDA GX240K1QAE2 ENGINE — IGNITION COIL ASSY.

IGNITION COIL ASSY.

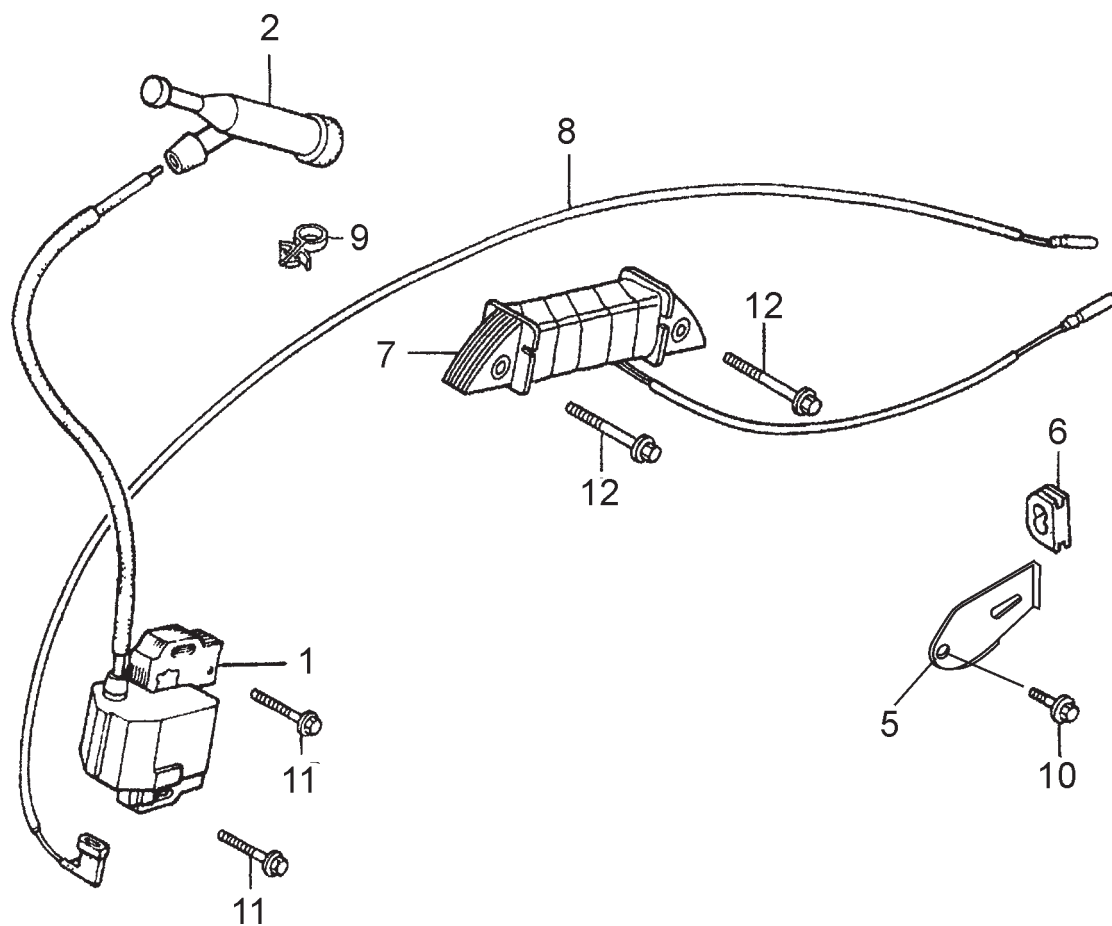

## HONDA GX240K1QAE2 ENGINE — IGNITION COIL ASSY.

### IGNITION COIL ASSY.

<u>NO.</u>	<u>PART NO.</u>	<u>PART NAME</u>	<u>QTY.</u>	<u>REMARKS</u>
1	30500ZE2023	COIL ASSY., IGNITION	1	
2	30700ZE1013	CAP ASSY., NOISE SUPPRESSOR	1	
5	31511ZE2000	CLAMP, WIRE	1	
6	31512ZE2000	GROMMET, WIRE	1	
7	31630ZE2841	COIL ASSY., CHARGE (3A)	1	
8	36101ZE1010	WIRE, STOP SWITCH 370MM	1	
9	36103ZE1000	HOLDER, STOP SWITCH WIRE	1	
10	90013883000	BOLT, FLANGE 6X12	1	
11	90015883000	BOLT, FLANGE 6X28	2	
12	90017883000	BOLT, FLANGE 6X32	2	

# HONDA GX390K1QAE2 — STARTER MOTOR ASSY.

STARTER MOTOR ASSY.

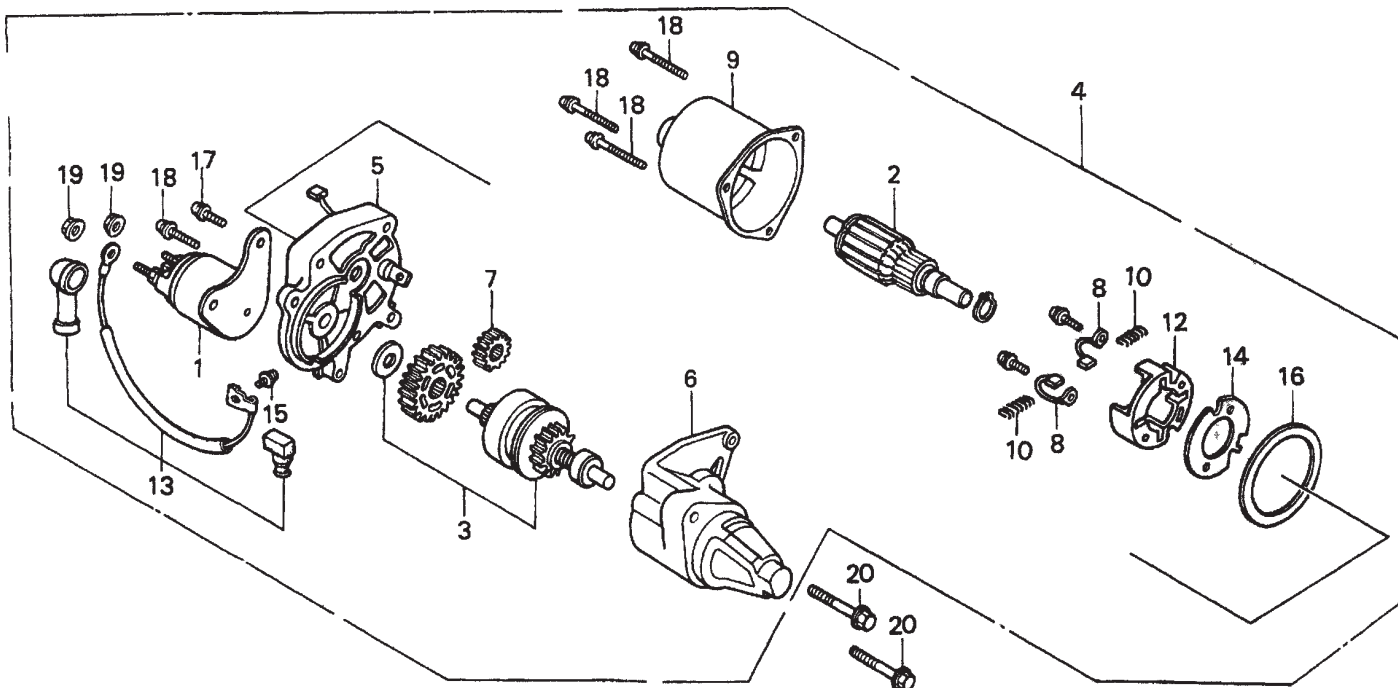

# HONDA GX390K1QAE2 — STARTER MOTOR ASSY.

## STARTER MOTOR ASSY.

<u>NO.</u>	<u>PART NO.</u>	<u>PART NAME</u>	<u>QTY.</u>	<u>REMARKS</u>
1*	31204ZA0003	CONTACTOR ASSY.	1	
2*	31217ZE2003	ARMATURE	1	
3*	31214ZE2003	CLUTCH OVERRUNNING	1	
4	31210ZE2003	MOTOR UNIT STARTER .....	1	INCLUDES ITEMS W/*
5*	31211ZE2003	BRACKET, CENTER	1	
6*	31212ZE2003	BRACKET, FRONT	1	
7*	31213ZE2003	GEAR, DRIVE PINION	1	
8*	31215ZE2003	BRUSH	2	
9*	31218ZE3003	YOKE	1	
10*	31219ZE2003	SPRING, BRUSH RETURN	4	
12*	31231ZE2003	HOLDER, BRUSH	1	
13*	31232ZE2013	WIRE, WATER COVER	1	
14*	31233ZE2003	INSULATOR	1	
15*	90110ZE2003	SCREW-WASHER (4X6)	1	
16*	91601ZE2003	GASKET	1	
17*	90007ZE2003	BOLT-WASHER (5X14)	2	
18*	938920503208	SCREW WASHER 5X3	4	
19*	9407006080	NUT-WASHER (6MM)	2	
20	957010804000	BOLT, FLANGE (8X35)	2	

# HONDA GX240K1QAE2 — CONTROL BOX ASSY.

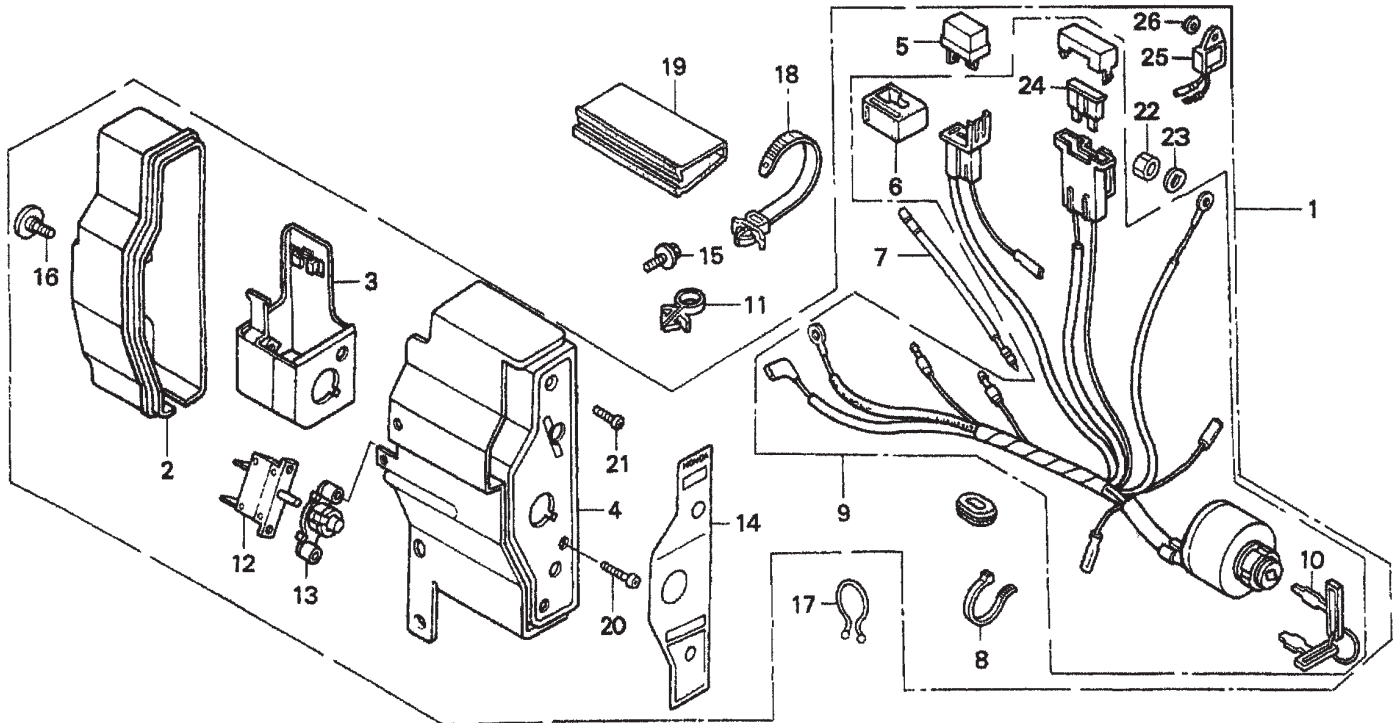

# HONDA GX240K1QAE2 — CONTROL BOX ASSY.

## CONTROL BOX ASSY.

<u>NO.</u>	<u>PART NO.</u>	<u>PART NAME</u>	<u>QTY.</u>	<u>REMARKS</u>
1	31610ZE2854ZB	CONTROL BOX ASSY. (EXT. ALERT) .....	1	INCLUDES ITEMS W/*
2*	31612ZE2003	CASE, CONTROL	1	
3*	31614ZE2003	BRACKET, CASE MOUNTING	1	
4*	31615ZE2003ZB	PANEL, CONTROL	1	
5*	31700124003	RECTIFIER, SILICON ASSY.	1	
6*#	32127738700	SUSPENSION, CONNECTOR	1	
7*	32197ZE1003	SUB-HARNESS	1	
8*	32902892003	BAND	1	
9*	35100ZE2842	SWITCH, COMBINATION ASSY. ....	1	INCLUDES ITEMS W/#
10*#	35111880003	KEY	2	
11	36103ZE1000	HOLDER, STOP SWITCH WIRE	1	
12*	38240ZE2840	PROTECTOR, CIRCUIT 3.5A	1	
13*	38250ZA8701	LENS, PROTECTOR ASSY.	1	
14*	87529ZE2811	PANEL, CONTROL BOX (EXTERNAL)	1	
15	90013883000	BOLT, FLANGE (6x12)	2	
16*	90380MA6010	SCREW, SPECIAL (6x12)	1	
17	90630751000	CLIP, PURSE LOCK	1	
18	90672SA0003	STRAP, CABLE 118mm	1	
19	91406ZE2003	TUBE, FASTENER	1	
20*	93500030120H	SCREW, PAN (3x12)	2	
21*	93500040120H	SCREW, PAN (4x12)	1	
22*	94001043900S	NUT, HEX (4mm)	2	
23*	9411104800	WASHER, SPRING (4mm)	1	
24*#	9820031500	FUSE, BLADE 15A	1	
25*	34150ZH7003	ALERT UNIT, OIL	1	
26*	9410104800	WASHER, FLAT (4mm)	1	

# HONDA GX240K1QAE2 ENGINE — MUFFLER ASSY.

MUFFLER ASSY.

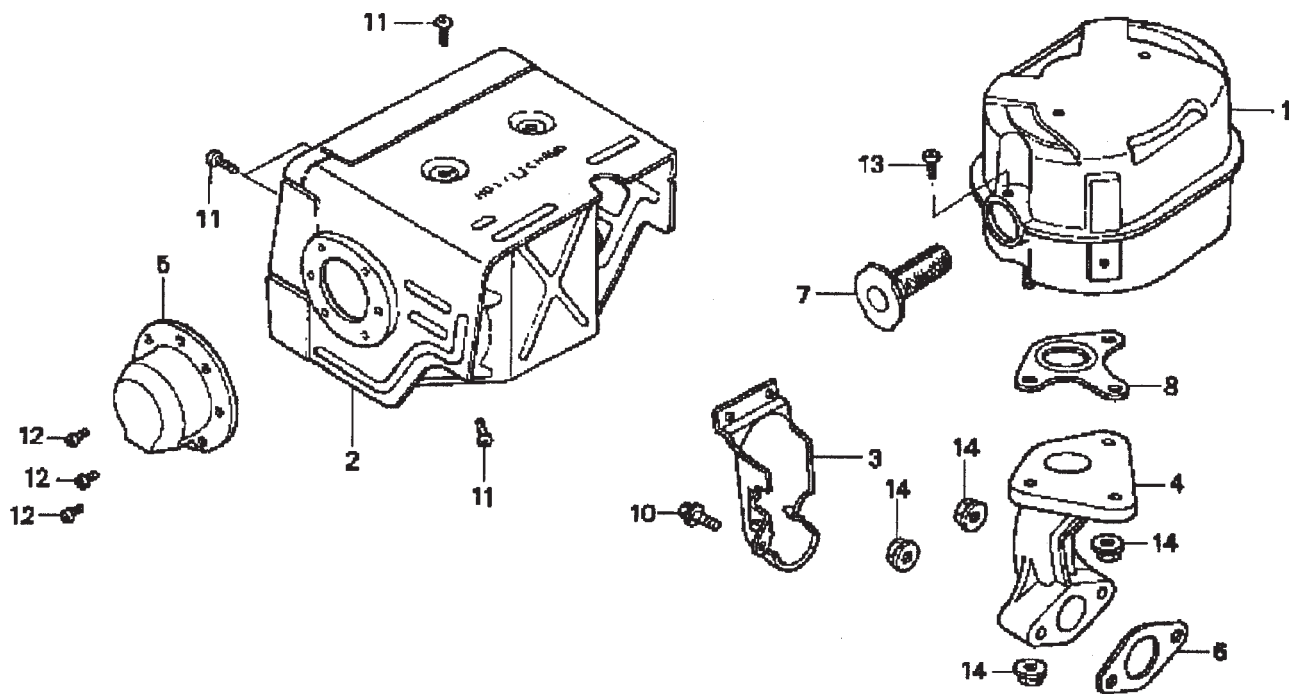



## HONDA GX240K1QAE2 ENGINE — MUFFLER ASSY.

### MUFFLER ASSY.

<u>NO.</u>	<u>PART NO.</u>	<u>PART NAME</u>	<u>QTY.</u>	<u>REMARKS</u>
1	18310ZE2W00	MUFFLER	1	
2	18320ZE2W01	PROTECTOR COMP., MUFFLER	1	
3	18323ZE2W00	PROTECTOR, EX. PIPE	1	
4	18330ZE2W00	PIPE, EX.	1	
5	18331ZE2810	CAP, MUFFLER	1	
6	18333ZE3800	GASKET, EX. PIPE	1	
7	18355ZE2010	ARRESTER, SPARK	1	
8	18381ZE2W10	GASKET, MUFFLER, ARRESTER	1	
10	90013883000	BOLT, FLANGE 6X12 CT200	1	
11	90050ZE1000	SCREW, TAPPING 5X8	6	
12	90055ZE1000	SCREW, TAPPING 4X6	3	
13	90050ZE1000	SCREW, TAPPING 5X8	1	
14	9405008000	NUT, FLANGE 8MM	5	

# HONDA GX240K1QAE2 ENGINE — PISTON ASSY.

PISTON ASSY.

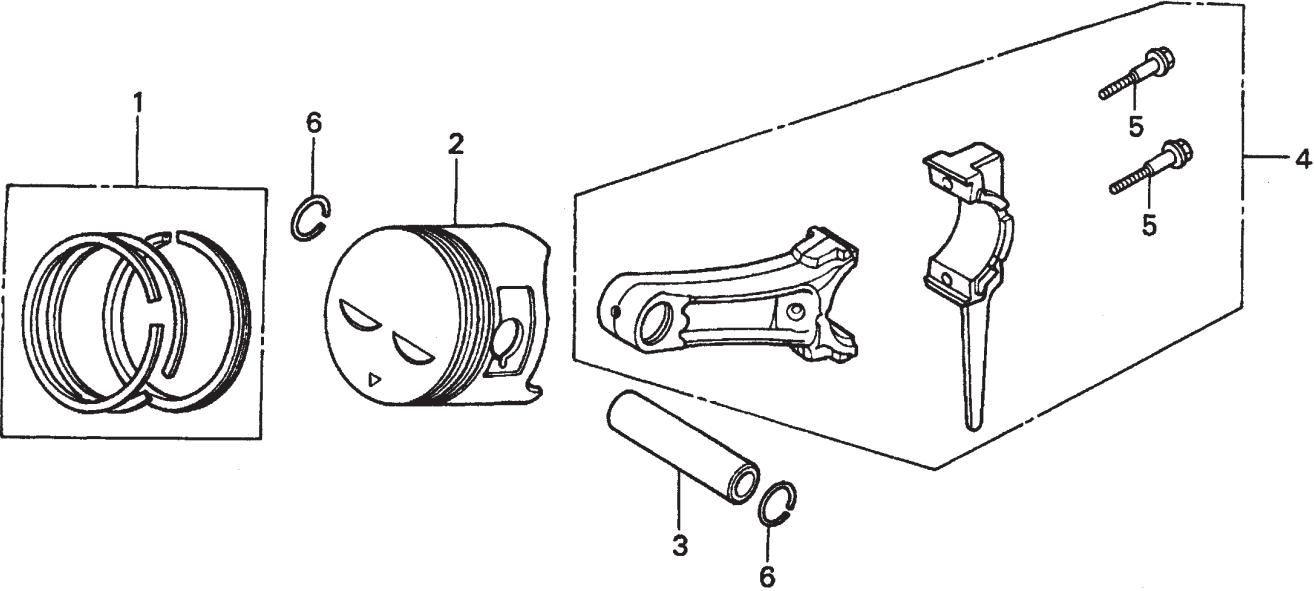

# HONDA GX240K1QAE2 ENGINE — PISTON ASSY.

PISTON ASSY.

<u>NO.</u>	<u>PART NO.</u>	<u>PART NAME</u>	<u>QTY.</u>	<u>REMARKS</u>
1	13010ZE2013	RING SET, PISTON, STD.	1	
1	13011ZE2013	RING SET, PISTON, OS 0.25, OPTIONAL	1	
1	13012ZE2013	RING SET, PISTON, OS 0.50, OPTIONAL	1	
1	13013ZE2013	RING SET, PISTON, 0.75, OPTIONAL	1	
2	13101ZE2W00	PISTON, STANDARD	1	
2	13102ZE2W00	PISTON, OS 0.25, OPTIONAL	1	
2	13103ZE2W00	PISTON, OS 0.50, OPTIONAL	1	
2	13104ZE2W00	PISTON, 0.75, OPTIONAL	1	
3	13111ZE2000	PIN, PISTON	1	
4	13200ZE2000	ROD ASSY., CONNECTING STANDARD .....	1	INCLUDES ITEMS W/*
4	13200ZE2305	ROD ASSY., CONNECTING, US 0.25, OPT. ....	1	INCLUDES ITEMS W/*
5*	90001ZE8000	BOLT, CONNECTING ROD	2	
6	90551ZE1000	CLIP, PISTON PIN 18MM	2	

# HONDA GX240K1QAE2 ENGINE — RECOIL STARTER ASSY.

RECOIL STARTER ASSY.

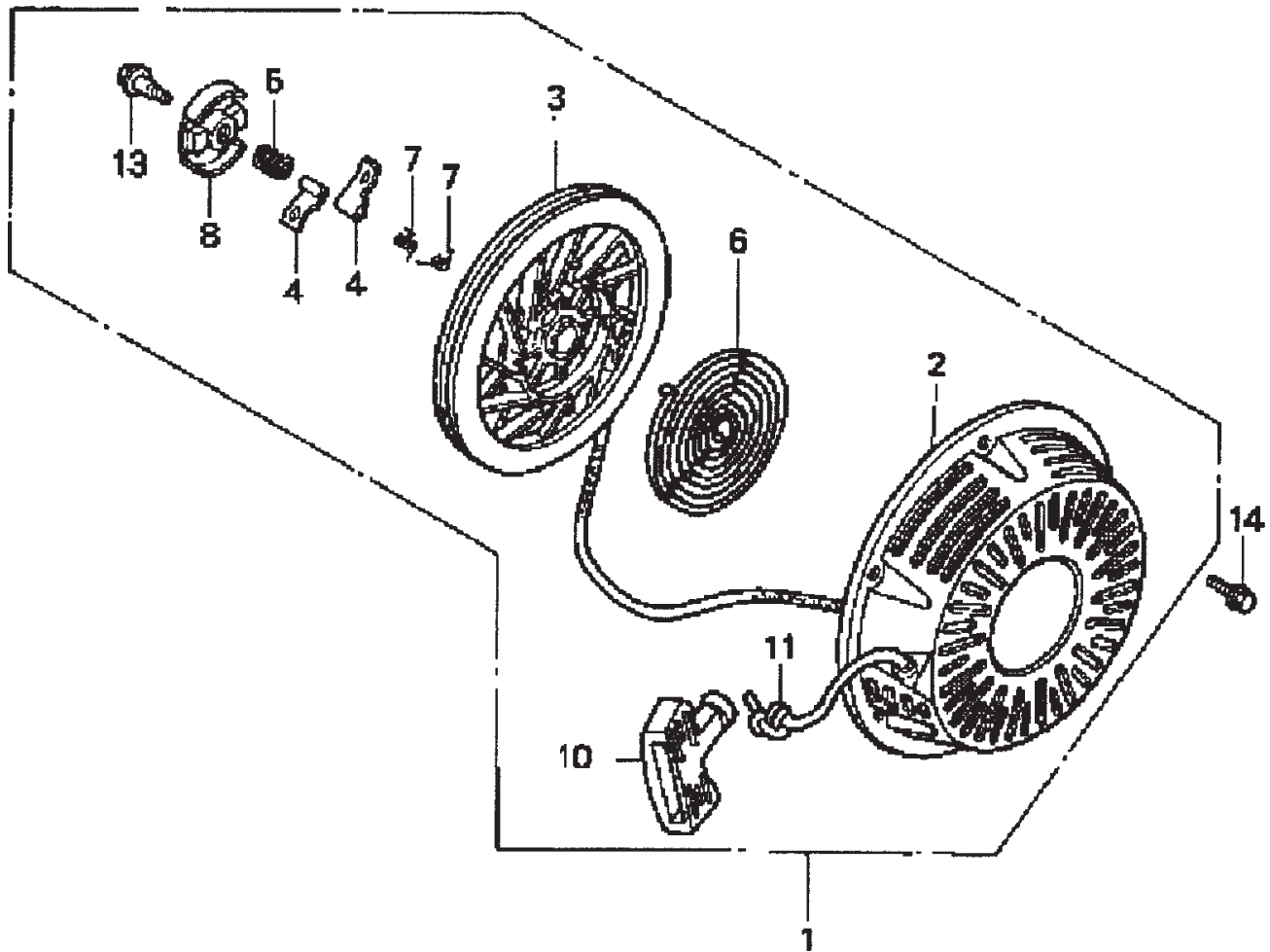

# HONDA GX240K1QAE2 ENGINE — RECOIL STARTER ASSY.

## RECOIL STARTER ASSY.

<u>NO.</u>	<u>PART NO.</u>	<u>PART NAME</u>	<u>QTY.</u>	<u>REMARKS</u>
1	28400ZE2W01ZA	STARTER ASSY., RECOIL *R8*, BRIGHT RED .....	1	INCLUDES ITEMS W/*
2*	28410ZE2W01ZA	CASE COMP., RECOIL STARTER *R8*, RED	1	
3*	28421ZE2W01	PULLEY, RECOIL STARTER	1	
4*	28422ZE2W01	RATCHET, STARTER	2	
5*	28441ZE2W01	SPRING, FRICTION	1	
6*	28442ZE2W01	SPRING, STARTER RETURN	1	
7*	28443ZE2W01	SPRING RATCHET	2	
8*	28444ZE2W01	RETAINER, SPRING	1	
10*	28461ZE2W02	GRIP, STARTER	1	
11*	28462ZE2W11	ROPE, RECOIL STARTER	1	
13*	90004ZE2W01	SCREW, CENTER	1	
14	90008ZE2003	BOLT, FLANGE 6X10	3	

# HONDA GX240K1QAE2 ENGINE — ENGINE LABELS

## ENGINE LABELS

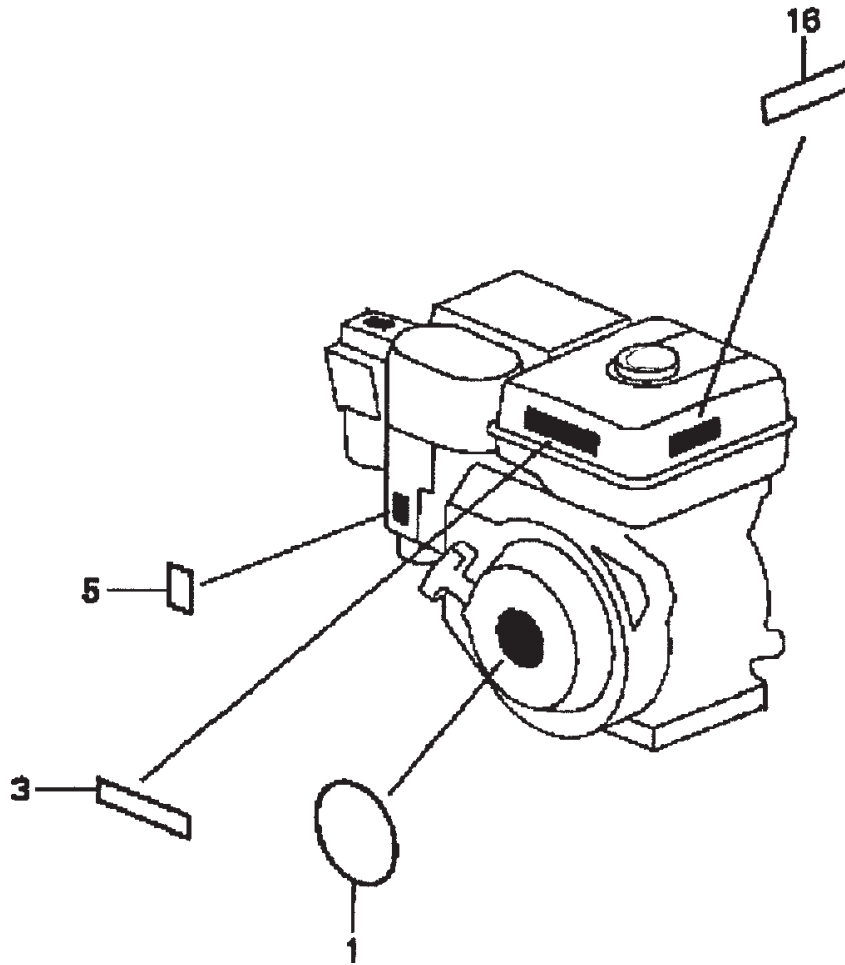

## HONDA GX240K1QAE2 ENGINE — ENGINE LABELS

### ENGINE LABELS

<u>NO.</u>	<u>PART NO.</u>	<u>PART NAME</u>	<u>QTY.</u>	<u>REMARKS</u>
1	87521ZE2W01	EMBLEM, INTERNAL	1	
3	87522ZH9000	LABEL, CAUTION	1	
5	87528ZE2810	MARK, CHOKE, EXTERNAL	1	
16	87532ZH8810	MARK, OIL ALERT, E	1	

# TERMS AND CONDITIONS OF SALE — PARTS

## PAYMENT TERMS

Terms of payment for parts are net 30 days.

## FREIGHT POLICY

All parts orders will be shipped collect or prepaid with the charges added to the invoice. All shipments are F.O.B. point of origin. Multiquip's responsibility ceases when a signed manifest has been obtained from the carrier, and any claim for shortage or damage must be settled between the consignee and the carrier.

## MINIMUM ORDER

The minimum charge for orders from Multiquip is \$15.00 net. Customers will be asked for instructions regarding handling of orders not meeting this requirement.

## RETURNED GOODS POLICY

Return shipments will be accepted and credit will be allowed, subject to the following provisions:

1. A Returned Material Authorization must be approved by Multiquip prior to shipment.
2. To obtain a Return Material Authorization, a list must be provided to Multiquip Parts Sales that defines item numbers, quantities, and descriptions of the items to be returned.
  - a. The parts numbers and descriptions must match the current parts price list.
  - b. The list must be typed or computer generated.
  - c. The list must state the reason(s) for the return.
  - d. The list must reference the sales order(s) or invoice(s) under which the items were originally purchased.
  - e. The list must include the name and phone number of the person requesting the RMA.
3. A copy of the Return Material Authorization must accompany the return shipment.
4. Freight is at the sender's expense. All parts must be returned freight prepaid to Multiquip's designated receiving point.

5. Parts must be in new and resalable condition, in the original Multiquip package (if any), and with Multiquip part numbers clearly marked.
6. The following items are not returnable:
  - a. Obsolete parts. (If an item is in the price book and shows as being replaced by another item, it is obsolete.)
  - b. Any parts with a limited shelf life (such as gaskets, seals, "O" rings, and other rubber parts) that were purchased more than six months prior to the return date.
  - c. Any line item with an extended dealer net price of less than \$5.00.
  - d. Special order items.
  - e. Electrical components.
  - f. Paint, chemicals, and lubricants.
  - g. Decals and paper products.
  - h. Items purchased in kits.
7. The sender will be notified of any material received that is not acceptable.
8. Such material will be held for five working days from notification, pending instructions. If a reply is not received within five days, the material will be returned to the sender at his expense.
9. Credit on returned parts will be issued at dealer net price at time of the original purchase, less a 15% restocking charge.
10. In cases where an item is accepted, for which the original purchase document can not be determined, the price will be based on the list price that was effective twelve months prior to the RMA date.
11. Credit issued will be applied to future purchases only.

## PRICING AND REBATES

Prices are subject to change without prior notice. Price changes are effective on a specific date and all orders received on or after that date will be billed at the revised price. Rebates for price declines and added charges for price increases will not be made for stock on hand at the time of any price change.

Multiquip reserves the right to quote and sell direct to Government agencies, and to Original Equipment Manufacturer accounts who use our products as integral parts of their own products.

## SPECIAL EXPEDITING SERVICE

A \$35.00 surcharge will be added to the invoice for special handling including bus shipments, insured parcel post or in cases where Multiquip must personally deliver the parts to the carrier.

## LIMITATIONS OF SELLER'S LIABILITY

Multiquip shall not be liable hereunder for damages in excess of the purchase price of the item with respect to which damages are claimed, and in no event shall Multiquip be liable for loss of profit or good will or for any other special, consequential or incidental damages.

## LIMITATION OF WARRANTIES

No warranties, express or implied, are made in connection with the sale of parts or trade accessories nor as to any engine not manufactured by Multiquip. Such warranties made in connection with the sale of new, complete units are made exclusively by a statement of warranty packaged with such units, and Multiquip neither assumes nor authorizes any person to assume for it any other obligation or liability whatever in connection with the sale of its products. Apart from such written statement of warranty, there are no warranties, express, implied or statutory, which extend beyond the description of the products on the face hereof.

Effective: February 22, 2006





# OPERATION AND PARTS MANUAL

## HERE'S HOW TO GET HELP

PLEASE HAVE THE MODEL AND SERIAL  
NUMBER ON-HAND WHEN CALLING

### UNITED STATES

#### *Multiquip Corporate Office*

18910 Wilmington Ave.  
Carson, CA 90746  
Contact: mq@multiquip.com

Tel. (800) 421-1244  
Fax (800) 537-3927

#### *Service Department*

800-421-1244  
310-537-3700

Fax: 310-537-4259

#### *Technical Assistance*

800-478-1244

Fax: 310-943-2238

#### *MQ Parts Department*

800-427-1244  
310-537-3700

Fax: 800-672-7877  
Fax: 310-637-3284

#### *Warranty Department*

800-421-1244  
310-537-3700

Fax: 310-537-1173

---

### MEXICO

#### *MQ Cipsa*

Carr. Fed. Mexico-Puebla KM 126.5  
Momoxpan, Cholula, Puebla 72760 Mexico  
Contact: pmastretta@cipsa.com.mx

Tel: (52) 222-225-9900  
Fax: (52) 222-285-0420

### CANADA

#### *Multiquip*

4110 Industriel Boul.  
Laval, Quebec, Canada H7L 6V3  
Contact: jmartin@multiquip.com

Tel: (450) 625-2244  
Tel: (877) 963-4411  
Fax: (450) 625-8664

---

### UNITED KINGDOM

#### *Multiquip (UK) Limited Head Office*

Unit 2, Northpoint Industrial Estate,  
Globe Lane,  
Dukinfield, Cheshire SK16 4UJ  
Contact: sales@multiquip.co.uk

Tel: 0161 339 2223  
Fax: 0161 339 3226

© COPYRIGHT 2010, MULTIQUIP INC.

Multiquip Inc and the MQ logo are registered trademarks of Multiquip Inc. and may not be used, reproduced, or altered without written permission. All other trademarks are the property of their respective owners and used with permission.

This manual MUST accompany the equipment at all times. This manual is considered a permanent part of the equipment and should remain with the unit if resold.

The information and specifications included in this publication were in effect at the time of approval for printing. Illustrations, descriptions, references and technical data contained in this manual are for guidance only and may not be considered as binding. Multiquip Inc. reserves the right to discontinue or change specifications, design or the information published in this publication at any time without notice and without incurring any obligations.

Your Local Dealer is:

